

**Don Lancaster's**



**Case Against  
Patents**

selected reprints from **Midnight Engineering**  
and **Nuts & Volts** magazines

Copyright c. 1993 by Don Lancaster and *Synergetics Press*, Box 809, Thatcher, AZ  
85552, (520) 428-4073.

ISBN 1-882193-71-7

Book-on-demand self-published using the *Apple IIe* computer and the *LaserJet 4M+*.  
All graphics were done in their entirety by *ProDOS AppleWriter 2.1*.



## Introduction

**F**or most hardware hackers and most small scale startups, any involvement with the patent system in any way, shape, or form is *virtually certain* to result in a net loss of your time, energy, money, and sanity. Mostly because of the outrageous and invariably dead-wrong popular mythology surrounding patents and patenting.

In reality, a patent is *only* the right to sue someone. Not one patent in 200 *ever* shows *any* net positive cash flow. There is not one patent in 1000 that cannot be thrown out or severely diminished, given a diligent enough search for prior art in obscure enough places. To be valid, patents *must* be truly and genuinely new, *must not* be obvious to a practitioner in the field, and *must* have *all* prior art fully and totally disclosed. Strictly meeting these three requirements in this day and age is virtually impossible.

Add to this the patent scamming industry. Which the *Wall Street Journal* now reports to be a \$114 million dollar a year industry. Wherein your money is taken and *nothing* useful is *ever* returned. One of these bad guys recently had to include total disclosures in their mailings. Of 2850 "customers", only *five* were ever successfully licensed. And only *one* of those ever showed a net positive cash flow.

Who, of course, was the brother-in-law of the firm's founder.

Rather than being essential for small scale product development, patents are a largely unneeded sideshow that, more often than not, are totally worthless and serve no useful purpose. And are virtually guaranteed to cost you time and money. In the real world, a potential manufacturer is infinitely more interested in working products now in active advanced beta test along with full preproduction artwork than they are in a mythical piece of paper that may or may not turn into anything.

Over the years, I have seen many individuals get totally done in by the patent system. Some of them even murdered by it. In suicides and heart-attack-during-litigation cases. I have also seen many individuals successfully develop and market countless products without ever going anywhere remotely near the patent system.

Now, patents may or may not be appropriate tools in a Fortune 500 context. But that is not our concern here.

For *not once* have I *ever* seen *any* individual show a net positive cash flow from patents as a small scale startup. *Ever*. If you don't believe me, just try and *personally* one-on-one find someone who has done so. And ask them face-to-face. You can forget those urban lore stories – look close and you'll find all of them to be *dead wrong*. At last check, the "windshield wiper guy" was permanently thrown out of court and told to never come back. After loosing many tens of millions of dollars. The truth behind the other urban lore patent myths are equally grim.

In this reprint collection, I've tried to gather together lots of info on tested and proven alternatives to the patent system. Techniques I have profitably used in the past and continue to use today. Methods that let you successfully develop and market technical innovations in a small scale environment.

I do offer ongoing help beyond what you see here. Give me a call at (520) 428-4073 or contact me at don@tinaja.com or visit my **Guru's Lair** web site at www.tinaja.com on the Internet for more assistance.

Don Lancaster  
Thatcher, Arizona

## About the Author

**A**s he has said in his classic *Incredible Secret Money Machine*, Don Lancaster writes books. And quests *tinajas*.

Microcomputer pioneer and guru Don Lancaster is now the author of 28 books and countless articles. He is considered by some to be the father of the personal computer, for his early ground-breaking work with hacker digital electronics and low cost video terminal displays. He is considered by others to be the patron saint of the Walter Mitties of the world. And, he is considered by yet others to be the... er, I guess we better skip that one.

His monthly columns include the *Resource Bin* column in *Nuts and Volts*, and his *Hardware Hacker* column in *Electronics Now* magazine. He is also the *Blatant Opportunist* in *Midnight Engineering*.

Some of his other titles include his *CMOS* and his million-seller *TTL Cookbooks*, *Micro Cookbooks* volumes *I* and *II*, *Enhancing your Apple II*, volumes *I* and *II*, the *AppleWriter Cookbook*, the *Active Filter Cookbook*, *Apple Assembly Cookbook*, his *Ask the Guru* and *Hardware Hacker* reprints, *Don Lancaster's PostScript Secrets*, and his *Intro to PostScript* video.

Don's current software offerings include his *PostScript Show and Tell*, plus a few companion disks for his various books. He also has his *Guru's Lair* website at [www.tinaja.com](http://www.tinaja.com), featuring PostScript and patent pages, and is a registered developer for several leading edge technical firms.

Don is also the head honcho of *Synergetics*, a new-age design and consulting firm that specializes in Apple computing, laser printing, *PostScript* program utilities, electronic prototyping, book-on-demand publishing, technical writing, and innovative software design. His avocations include firefighting, cave exploration, bicycling, and, of course, *tinaja* questing.

Don maintains a no charge voice helpline found at (520) 428-4073. He welcomes your calls and letters. Best calling times are 8-5 weekdays, *Mountain Standard Time*. ♦

# Patents Package Contents

- The Case Against Patents** Blatant Opportunist 6, *Midnight Engineering*, Nov-Dec 1990.
- Perils and Pitfalls of Patents and Patenting** Resource Bin 13, *Nuts and Volts*, Feb 1993.
- Patently Horrible** Blatant Opportunist 22, *Midnight Engineering*, July-Aug 1993.
- When to Patent** Blatant Opportunist 29, *Midnight Engineering*, Sept-Oct 1994.
- A New Patent Repository** Tech Musings 113, *Electronics Now*, June 1997.
- Risk Reduction** Blatant Opportunist 24, *Midnight Engineering*, Nov-Dec 1993.
- Another Patent Horror Story** Tech Musings 93, *Electronics Now*, Oct 1995.
- Busting a \$650 Patent** Blatant Opportunist 45, *www.tinaja.com*, July-Aug 1997.
- Inventor's Associations** Blatant Opportunist 18, *Midnight Engineering*, Nov-Dec 1992.
- Starting Up Your Own Technical Venture** Resource Bin 14, *Nuts & Volts*, March 1993.
- Insider Research Secrets** Blatant Opportunist 13, *Midnight Engineering*, Jan-Feb 1992.
- My Secrets of Web-based Research** Resource Bin 71, *Nuts & Volts*, Dec 1997.
- Conducting Your Own Personal Research** Resource Bin 30, *Nuts and Volts*, June 1994.
- Starting Off Your Resource Quest** Resource Bin 1, *Nuts and Volts*, Feb 1992.
- Oddball Sources for Just Plain Stuff** Resource Bin 10, *Nuts and Volts*, Nov 1992.
- Stupendous Stuff Sources** Blatant Opportunist 2, *Midnight Engineering*, Mar-Apr 1990.
- A Look at Online Resources & Opportunities** Resource Bin 22, *Nuts & Volts*, Nov 1993.
- Stalking The Wild Paradigm** Blatant Opportunist 8, *Midnight Engineering*, Mar-Apr 1991.
- Emerging Technologies I** Blatant Opportunist 4, *Midnight Engineering*, July-Aug 1990.
- Emerging Technologies II** Blatant Opportunist 17, *Midnight Engineering*, Sept-Oct 1992.
- Emerging Opportunities III** Blatant Opportunist 27, *Midnight Engineering*, May-June 1994.
- Emerging Technical Opportunities IV** Blatant Opportunist 37, *Midnight Engineering*, Mar-Apr 1996.

# Patents Package Contents

**Emerging Technical Opportunities V** Blatant Opportunist 44, *Midnight Engineering*, May-June 1997.

**Product Development Concepts** Tech Musings 95, *Electronics Now*, Dec 1995.

**Secrets of Professional Prototypes** Resource Bin 15, *Nuts and Volts*, April 1993.

**\$99 Flutterwumpers** Blatant Opportunist 30, *Midnight Engineering*, Nov-Dec 1994.

**Opportunities in Hacker Robotics** Resource Bin 16, *Nuts and Volts*, May 1993.

**A Look at Sensors & Sensing** Resource Bin 37, *Nuts and Volts*, Feb 1995.

**Elegant Simplicity** Blatant Opportunist 25, *Midnight Engineering*, Jan-Feb 1994.

**Engineering Ratholes** Blatant Opportunist 32, *Midnight Engineering*, Mar-Apr 1995.

**Engineering Economics** Hardware Hacker 86, *Electronics Now*, March 1995.

**For More Help**

**Names & Numbers** The Complete Master Resource List

by Don Lancaster

# The Case Against Patents

Let's start off with a seemingly simple quiz – Which of the following is the most likely to cause you no end of grief?

- (A) Dealing noontime crack on the front stairs of the Salt Lake City police station.
- (B) Shooting a sequence of kiddy porno videos in the basement of your favorite church.
- (C) Calling yourself an inventor and behaving like one.

A trick question, of course. Given the normal franchise prepayments and when handled as a class act, (A) and (B) will both have considerable upside potential and a rather well defined risk to reward ratio. (C) is *certain* to be an absolute and total loss.

Over the years, "they" have defined any *inventor* as a mark to be conned. As a sheep to get shorn, gang raped, flayed alive, and finally nailed to the nearest shed.

Now, it is fine to be an *industrial product developer*, run a *prototyping house*, or be a *concept consultant* or an *evaluation specialist*. All of these are acceptable roles in society for which, at least occasionally, you may end up being quite well rewarded. These are also the sorts of things that you, as a *Midnight Engineer* should be striving towards. Upward and onward.

But don't *ever* refer to yourself as an inventor or act like one, for you are certain to end up done in very badly. Don't ever let anyone even suspect that you are capable of inventing anything.

Those invention marketing services with the tiny classified ads are not really the main problem. These folks are basically selling dreams and wish fulfillment in much the same way as a vanity publisher or, for that matter, an X-rated movie rental. Since the use of any invention marketing firm is the guaranteed kiss of death for any new product, these also do serve a useful purpose in helping keep abysmal junk out of the marketplace.

The patent process itself is by far the worst offender in inventor bashing. If a Las Vegas casino operator had the gross effontery to offer the same odds the patent office does, they would be tarred, feathered, and run out of town on a rail. If it were not a government bureaucracy, the patent office would long ago have been shut down under the RICO racketeering act.

Now, the patent system may or may not still retain some marginal utility in a Fortune 500 context. But, as a small scale *Midnight Engineer* or *Hardware Hacker*, *any involvement whatsoever with the patent system in any way,*

*shape, or form, is virtually guaranteed to cause you a monumental long term loss of time, money, and sanity.*

I'd guess the main problem is the mythology that has built up around the patent process over all the years. A mythology that no longer applies to the *Midnight Engineer* or the small scale startup. Let's try and replace the myths with some cold hard facts...

**Fact – Your patent does not in any manner prevent others from stealing or using your ideas.**

Should you go patent something, anyone is totally free to market your product, rip off all your ideas, or tell others about your work. And there is nothing immediate you can do to stop this from happening.

All a patent does is give you the right to sue someone in a civil action. At some future date in a ridiculously costly, extremely drawn out and easily circumvented legal process.

Nobody has ever "won" any patent litigation. The sole purpose of patent fights are to cause more grief and harm to the opposition than you are causing yourself. Almost always, this purpose fails miserably.

**Fact – Not one patent in one hundred ever shows any positive cash flow.**

There have been lots of studies done on patent productivity. While most of these cite ratios of several hundred to one or higher, 100:1 is a good and very generous working figure. Thus, your state lottery is usually a vastly better investment than a patent.

**Fact – There is not one patent in one thousand that cannot be invalidated or severely minimized by a diligent enough search for prior art done in obscure enough places.**

**Don't ever refer to yourself as an inventor, for you are certain to end up done in very badly.**

Very simply, there are zillions of people worldwide who are inventing things. And they all have pretty much the same tools and technology at their disposal. Almost certainly, you are not first with your idea. All it takes

is some provable *prior art* anywhere, and your patent is patently useless.

**Fact – Prior art is not needed to bust any patent.**

All you really have to do is show that the claims would have been reasonably obvious to a "practitioner in the field." That's all it takes.

As is often the case, a patent search is made without

---

actually looking at any of the *non-patent* history of the field in the way of key papers, seminars and trade journals. All you have to do is find someone somewhere that says it sure would have been obvious to them.

*When* (not *if*) your patent ends up busted, you will also run the risk of a *frivolous litigation* countersuit. Thus, if you have the temerity to try and defend your patent, you could end up being fined thousands of dollars.

**Fact – Ideas are usually worthless.**

At one time, way back in the golden age of inventing, ideas were worth as much as a dime a dozen. These days, they are worth less than a dime a bale in ten bale lots.

An idea becomes useful only *when and if* it can get converted into some marketable product that in fact ends up solving end user needs.

If you cannot demonstrate end users getting off on your idea, it has no value. It ain't creative unless it sells.

**Fact – Big industry does NOT buy ideas or patents.**

Change of any kind is anathema to any large Fortune 500 corporation. The only reason a new or improved product is ever released is in response to a clear threat of losing market share. Even then (as was obviously the case with minicomputer manufacturers), a larger corporation may choose to drop the ball completely, rather than adapting to any sorely needed change.

Consistently, it is all those garage startups and other smaller companies that introduce innovation and change to the marketplace. Only when those changes are overwhelmingly superior does big business pay attention.

Many larger corporations have a policy of flat out rejecting any outside invention submission. The reason for this is simple – several millions of dollars of in-house ongoing research and development could be lost should some outside epsilon minus and his attorney scream "You stole my idea!"

The NIH (Not Invented Here) syndrome is alive and well in most larger firms. It looks bad when the R&D staff gets blown out of the water by some kid in a garage somewhere.

So even if you have an absolutely outstanding new idea with rock solid patents behind it, most of industry simply could not care less.

**Fact – Nobody voluntarily pays any patent royalties.**

Nearly any company would much prefer to give their legal department \$100,000 to bust your patent before they would ever stoop to paying you \$10,000 in royalties. Outside patents are something to be ignored, avoided, worked around, or outright busted in court. But *never* to be honored.

**Fact – You WILL get ripped off.**

The odds are very much stacked against the Midnight Engineer startup from day one. If you are a creative type that designs things, the chances are you got that way in the first place through ignoring people and legal details. So, you *will* have your ideas stolen. You *will* be lied to. You *will* be misled.

The trick here is to recognize the inevitability of this ripoff process and not get too upset when it happens.

Ripoffs come with the territory. So, factor them in ahead of a time and it won't be nearly as rude a surprise when it

surely happens to you.

**Some Better Alternatives –**

So, if you are a Midnight Engineer, what are the alternative methods for successfully marketing your ideas and concepts? Based on many years of personal experience and several cubic yards of overflowing third-party patent victim files, here's what I'd suggest...

First, you *totally* avoid any and all contact with anything even remotely patent related. In any way, shape or form. Do so religiously.

Second, don't even bother creating anything in any field in which you are not eventually certain to become an expert. An expert who is thoroughly familiar with the technical literature, the history of the field, the marketing realities, the insider trade journals, and the mainstream tools and techniques in use. There is no point whatsoever in writing forest fire simulation software if you have never sharpened a *Pulaski*. Nor (as sadly happened to yet another victim just this morning) in patenting a "new way to replace inductors" without having read and understood *Sallen and Key* in their 1955 classic paper.

Third, publish all your key secrets and ideas in a major magazine, leaving out no detail, and omitting no insider secrets. This immediately can generate positive cash flow for you and safely tucks all your ideas away in the public domain, preventing most others from attempting to patent them. This also exposes your new ideas to the widest possible audience.

Fourth, try to set up some royalty arrangement with a small to medium firm in some position to market and distribute your invention. A normal royalty payment is typically in the five percent range. Now for the tricky part: *They must come to you*, and *never* vice versa. That is why it is super important to publish your ideas and creations and expose them as widely as possible.

You should have one and only one defense against getting ripped off in any royalty setup – the expectation that you will be delivering newer and better stuff in the future. That's all.

Fifth, employ the *shotgun* technique. There is no way that one single idea or product will hack it. To survive in this game, you'll need hundreds or even thousands of new ideas and concepts working for you on a total lifetime and total lifestyle basis. Chances are that one or two genuine winners will pay for all the others lost or stolen.

Finally, be realistic. You don't create things to get filthy rich. You create things because you like to create things and have some compelling desire or need to do so. As long as there are enough nickels to keep going, that is all that should really matter. ♦

---

*Microcomputer pioneer and guru Don Lancaster is the author of 26 books and countless articles. Don now maintains a no-charge technical helpline you will find at (602) 428-4073, besides offering all of his own books, reprints, and various services. He also has a free brochure chock full of his new insider desktop publishing secrets waiting just for you. Your best calling times are 8-5 on weekdays, Mountain Standard Time. Or you can reach Don by way of his Synergetics, at Box 809, Thatcher, AZ 85552.*



Don Lancaster's

# RESOURCE BIN

number thirteen

Perils and pitfalls of patents and patenting.

Our usual reminder here that the *Resource Bin* is now a two-way column. You can get tech help, consultant referrals and off-the-wall networking on nearly any electronic, *tinaja questing*, personal publishing, money machine, or computer topic by calling me at (602) 428-4073 weekdays 8-5 MST. I've got a free pair of insider secret resources brochures waiting for you when you call or write.

This month, I thought we'd take a slightly different tack. Instead of my showing you lots of great places to get stuff, I will be showing you the *one* resource that you should studiously avoid at all costs. Because it is *certain* to waste your time, energy, money, and sanity.

The term *mark* first came from the carnival midway. Any time a scam operator (the *rube* in carneyspeak) had significantly lightened a prospect's wallet, he would give him a friendly exiting pat on the back. Along with a supporting "Gee Fella, that's too bad."

Unmentioned and unbeknownst to the lightenee was the fact that the rube had secretly dipped his hand in a hidden stash of powdered chalk just before the pat on the back. And thus *marking* a large "X" on the lightenee, clearly identifying him as worthy of special treatment by the next rube on down the line.

Eventually, every non-rube who so much as entered the carnival midway area became known as a mark. And were contemptuously treated as such.

These days, we no longer have too many marks left. So, you substitute the term *inventor* instead. Any time an "inventor" context crops up, you are assured of an uneven playing field very much comparable to a carnival midway or a casino floor. A scene which is intended primarily to (A) liberate as much money as possible from the mark, and (B) to keep the status quo exactly where it is.

The foremost reason to studiously avoid any "inventor" context is the totally absurd popular mythology which now surrounds patents and inventing. Nearly all of which is dead wrong. To prove this to yourself, just mention the word "patent" at any party and then observe the ludicrous disinformation heaped upon you.

Then challenge them to name *one* individual anywhere, ever, *whom they personally know* that, *in a small scale context*, has shown a net positive cash flow from their patent involvement. A cash flow that was worth the time and effort involved.

No, the windshield wiper guy has not collected yet. The Sears wrench dude has wasted his entire lifetime by tilting at windmills. To me, Hyatt looks like a rube. Tesla died a pauper. The patent system drove Armstrong to suicide. And Edison was a ripoff artist who made most of his bag by simple theft, using the most ruthless gaggle of renegade patent attorneys ever assembled anywhere.

So much for urban lore.

Now, patents might or might not retain at least a marginal utility in a Fortune 500 context. Our concern here

**NEXT MONTH: Secrets of starting up your very own craft or tech venture.**

is simply whether patents are a useful or appropriate tool for a small scale startup or an individual.

Out of some *six million* patents filed to date, I have yet to find *one* example of a lone individual who has profited from patents. On the other hand, my patent victim files are bursting at the seams. Putting my money where my mouth is, a free new *Incredible Secret Money Machine II* to any current *Nuts & Volts* subscriber who is now able to

personally claim a worthwhile net positive cash flow from their patent involvement done as an individual or small scale startup.

As a mark and not a rube, of course.

Your second largest reason for the uneven playing field is the patent system itself. Over the years, I have observed that *any individual or other small scale involvement in the patent system is virtually certain to end up as a net loss of time, energy, money, and sanity*. Most often, your state lottery is a vastly better investment.

Very simply, patents are almost always inappropriate, time-wasting, counterproductive, vibe-destroying, and totally unnecessary tools. At least when misapplied within small scale or individual contexts.

It is fine to serve as an *industrial product developer*, or run a *prototyping house*, be a *concept consultant*, or work as an *evaluation specialist*. All of these form acceptable roles in society for which, at least occasionally, you might end up being well rewarded. These are also the sorts of things you should be striving towards.

Now, I simply cannot fathom why anyone would ever purposely refer to themselves as an "inventor". This is the same as pre-chalking yourself up before you enter the carney midway. Which leads us up to Horschnogge's first and second rules...

**RULE #1- Do not ever, under any circumstances, refer to yourself as an inventor or behave like one.** To do so will open you to interminable scams. Don't even let anyone else so much as suspect that you are even capable of inventing or marketing anything.

**RULE #2- If you ever do associate yourself with any inventor's resource, use a fake name and wear a disguise.** Remember that you are an impartial observer and a disinterested outsider. You are neither a mark nor a rube.

## The Facts

Let's replace the popular myths with some cold, hard facts...

(A) A patent is only the right to sue someone in a costly and lengthy civil court action.

(B) The cost and time to get a patent is utterly negligible compared to the cost and time required to defend and maintain a patent.

(C) Fewer than one patent in one hundred ever shows any net positive cash flow. Your state lottery is a *much* better investment.

(D) Fewer than one patent in one thousand could survive any diligent enough search for prior art in obscure enough places.

(E) Prior art is not needed to bust a patent. All you have to do is show it was obvious to a practitioner in the field. All prior art *must* be shown.

(F) Ideas are worth less than ten cents a bale in ten bale lots. It is only the final out-the-door products that potentially have any value.

(G) Most firms would rather pay their legal department \$100,000 to bust your patent than stoop to paying you \$10,000 in royalties.

(H) Winning ideas are *always* stolen. You *will* get ripped off.

(I) To work within the US patent system takes a lifetime commitment to lawyers, courtrooms, and legal issues. Time infinitely better spent improving your products.

## Inventor's Organizations

Yes, there are a lot of inventor's organizations out there. Hundreds of them in fact. I've recently spent a lot of time and effort gathering together what I believe is the most recent and complete list available anywhere. I've now posted this resource as my #538 INVENORG.PS up to GENIE PSRT. This unique listing is also available in my *Blatant Opportunist* reprints from my *Midnight Engineering* columns.

I like to think of these groups as a meadow that is full of wolves, sheep, shepherds, and watchdogs. The wolves are all of those commercial invention marketing services. The sheep are the inventor's self-help support groups. The shepherds are those government bureaucrats, who'll usually do more harm than good. And the watchdogs

are the few unique individuals who have dedicated their lives to keeping all the sheep out of trouble.

The three organizations that I can personally recommend include Bobbi Toole's *United Inventor's Association*, Ray Watts of the *Inventor's Assistance Program*, and Ed Zimmer, who works with the *Michigan Inventor's Council*.

## Invention Marketing Services

Everybody picks on poor old lobo. Yet *canis lupis* gotta eat. And they do cull the herd of the weak, the infirm, or, in this case, the abysmally naive and the monumentally dumb.

The wolves, of course, are all those invention marketing firms. You can get a complete list of these by cutting out all the fine print classified ads in *Popular Science* or *Popular Mechanics*, *Entrepreneur*, and similar places that scream "Inventions Wanted".

Just as typical vanity publishing offprints form the kiss of death for a first novel, many invention marketing firms are the kiss of death for any developable product. These outfits are basically hired guns, who, for a price up front, do perform various services. Such as patent searches, data bases, press releases, or invention fairs. You already know what an invention fair is - That's a place where you go to steal the few good ideas and laugh at all the rest of them.

You normally would not ask an ad agency if you needed an ad. Nor a used car dealer if you needed a car. Nor a mugger if you needed mugged. So what answer would you expect if you asked an invention marketing firm if your new idea was worthy of development? Give me a break.

The wolves are largely responsible for all of the absurd popular patent mythology. That quarter you sent in for your *inventor's idea kit* from a classified *Popular Mechanics* ad in the seventh grade has caused far more damage to far more people than you could possibly imagine. The whole "Get an idea" - "Patent It" - "Beat the cash-waving Fortune 500 companies away with a stick" - "Retire rich and famous" outright ludicrousities can all clearly be traced to these insidious, vile, and despicable classifieds.

One of the largest and oldest of these invention marketing firms has recently decided (possibly with the slightest of federal nudges) to include their track record with their original mailings. The odds of them licensing an accepted and prepaid idea has

new from  
**DON LANCASTER**

### ACTIVE FILTER COOKBOOK

The sixteenth (!) printing of Don's bible on analog op-amp lowpass, bandpass, and highpass active filters. De-mystified instant designs. **\$24.50**

### CMOS AND TTL COOKBOOKS

Millions of copies in print worldwide. THE two books for digital integrated circuit fundamentals. About as hands-on as you can get. **\$24.50** each.

### INCREDIBLE SECRET MONEY MACHINE II

Updated 2nd edition of Don's classic on setting up your own technical or craft venture. **\$18.50**

### LANCASTER CLASSICS LIBRARY

Don's best early stuff at a bargain price. Includes the CMOS Cookbook, The TTL Cookbook, Active Filter Cookbook, Micro Cookbooks I & II, newly revised Incredible Secret Money Machine II, and those Hardware Hacker II reprints. **\$119.50**

### LOTS OF OTHER GOODIES

Ask the Guru I or II or III .....	\$24.50
Hardware Hacker II or III .....	\$24.50
Book-on-Demand Resource Kit .....	\$39.50
PostScript Beginner Stuff .....	\$39.50
Intro to PostScript Video .....	\$39.50
GENIE PSRT Sampler .....	\$29.50
PostScript Reference II .....	\$28.50
PostScript Tutorial/Cookbook .....	\$16.50
Whole works (all PostScript) .....	\$350.00
PostScript Secrets Brochure .....	FREE
Hacking Secrets Brochure .....	FREE

### POSTSCRIPT SECRETS

A Book/Disk combination crammed full of free fonts, insider resources, utilities, publications, workarounds, fontgrabbing, more. For most any PostScript printer. Mac or PC format. **\$39.50**

### BLATANT OPPORTUNIST I

The reprints from all Don's *Midnight Engineering* columns. Includes the case against patents, book on demand publishing, toner secrets, paradigm stalking, insider research, lots more. **\$24.50**

### RESOURCE BIN I

A complete collection of all Don's Nuts & Volts columns to date, including a new index and his master names and numbers list. **\$12.50**

### FREE SAMPLES

Well, nearly free anyway. Almost. Do join us on GENIE PSRT to sample all of the Guru's goodies. The downloading cost on a typical Guru file is 21 cents. Call (800) 638-9636 for connect info.

FREE VOICE HELPLINE VISA/MC

## SYNERGETICS

BOX 809-NV  
Thatcher, AZ 85552  
(602) 428-4073

Write in 146 on Reader Service Card.

## RESOURCE BIN NAMES & NUMBERS

**Dialog Info Service**  
3460 Hillview Avenue  
Palo Alto CA 94304  
(415) 858-2700

**GENie**  
401 N Washington St  
Rockville MD 20850  
(800) 638-9636

**Midnight Engineering**  
111 E Drake Rd S7041  
Ft Collins CO 80525  
(303) 491-9092

**Synergetics**  
Box 809  
Thatcher AZ 85552  
(602) 428-4073

**Bobbi Tool, United Inventors**  
Box 50294  
St Louis, MO 63105  
(314) 721-2005

**US Dept of Commerce**  
Patent & Trademark Office  
Washington, DC 20231  
(800) 359-3997

**Raymond Watts**  
Inventor-Assistance Program  
Battelle NW Box 999 K6-54  
Richland, WA 99352

**Ed Zimmer, MI Inventors**  
1683 Plymouth Road  
Ann Arbor, MI 48103  
(313) 663-8000

been 100:1 against, and the odds for any positive cash flow comes in at 700:1 against. Of the few which did show positive results, most of them flat out were not worth the effort.

Now, some people may be appalled at these figures, but they sound about right to me. Successfully turning any raw concept into a positive cash flow is one very rough row to hoe. These odds may in fact be much *better* than you can do on your own.

In many ways, the wolves are just selling wish fulfillment and dreams. Again similar to a vanity publisher or, for that matter, an X-rated vid rental. If anything, I pretty much admire the wolves rather than condemn any of them. After all, a well executed scam is a joy to behold.

And an art form unto itself.

Typical inventors who actually use these invention marketing firms have already preshot themselves in the foot before they've begun and literally do not have a snowball's chance in hell of accomplishing anything.

Almost always, your "new" and "unique" idea is not. Chances are that others have plowed this ground long ago. If not, "synchronicity" just about guarantees that lots of others are now thinking along the same lines.

Over the years, I have developed many ideas and concepts. Several of which I have or continue to receive royalties over. And continue to center my lifestyle on. Countless others of which have failed miserably. On the basis of my own track record and on those of some winning associates, I strongly feel that the following are *absolutely essential* if you are going to

profit from a concept or idea:

(A) You must now be a reasonably experienced industry insider, who is eventually capable of turning into a guru or expert.

(B) You have to very aggressively subscribe to all of the more popular industry trade journals.

(C) You must know and love the mainstream industry tools and their supporting math, along with all of the theoretical underpinnings.

(D) You must tune in to the related trade groups, scholarly organizations, on-line resources (especially Dialog), and industry shows.

(E) You must be very aware of the political, legislative, competitive, and marketing realities of the target field.

(F) You must be in an area where innovation by individuals on a small scale is welcomed, rather than being regulated, legislated, or adjudicated excessively. Put another way, if it is automotive, forget it.

(G) Your preproduction prototypes must be in or beyond their advanced beta testing stage and have to clearly fill some unique needs or perceived needs in the mind of your end users. And, of course...

(H) You must studiously and very religiously avoid any and all contact with the patent system in any way, shape, or form.

I very strongly feel that omitting any of these core requirements can cause your new idea or concept to fail.

Many users of those wolf resources fail on *all* counts, not just a few.

## Invention Pitfalls

What are the usual mistakes that beginning inventors and small scale startups usually make? Based on my patent victim files and your helpline calls, here's a bunch of them...

(A) The tendency to grossly and obscenely overvalue all unproven or undeveloped ideas; to assume that patents are somehow central to idea creation and marketing rather than an avoidable, costly, risky, and largely unneeded sideshow; and to assume that others are as excited as you are about your product or will place your interests over their own.

(B) Not recognizing that the *only* three responses to a "you are violating my patent" letter are to ignore the letter; to bust the patent; or obsolete the technology. Besides the obvious side effect of permanently pissing off your potential finest customer and making yourself an enemy for life. The totally unthinkable possibility of voluntarily paying patent royalties just does not come up. Ever.

(C) To assume that big industry (especially Fortune 500 companies) are actively seeking new products. In reality, most large organizations will avoid all change and will categorically refuse to so much as look at *any* outside submissions because of all the liability hassles. Innovation *always* comes from individuals and smaller startup firms.

(D) Trying to work towards the spectacular (and nonexistent) big win, rather than accepting simple and solid returns done over and over again. An average well developed idea should typically return around \$400 or so. If you are playing at a million to one odds, then you don't want to put more than a dollar of time or effort up for every potential million in expected returns. Ever.

(E) Assuming that others may be willing to pay more for some mythical and unproven sheet of paper instead of buying the solid risk reduction of beta tested, fully working prototypes and ready-to-use production artwork.

(F) Forgetting that not less than 95 percent of most any survivable patent search must be done in the industry trade journals, scholarly publications, and the on-line resources. The patent

system is your very *last* place to look for prior art.

(G) Failing to recognize that trying to profit from the patent system takes a lifetime total commitment to courts and courtrooms, to lawyers and legal hassles. Compared to lots of creative lab time spent actually developing and improving products.

(H) Not remembering that ideas are like pancakes or children. You should always throw the first one away.

### Alternates to Patenting

The alternate to patenting that have worked best for me are...

(A) *Totally* avoid any and all contact with anything even remotely patent related. In any way, shape or form. Do so religiously.

(B) Do not even think of creating anything in any field in which you are not eventually certain to become an expert. An expert who is thoroughly familiar with the technical literature, the history of the field, the marketing realities, the insider trade journals, and the mainstream tools in use.

(C) Publish all your key secrets and ideas in a major magazine, leaving out no details, and omitting no insider secrets. This immediately produces positive cash flow for you and safely tucks all your ideas away in the public domain, preventing most others from attempting to patent them. This also exposes your new ideas to the widest possible audience.

(D) Attempt to set up some royalty arrangement with a small to medium firm in some position to market and distribute your invention. A normal royalty payment is typically in the five percent range. Now for the tricky part: *They must come to you*, and *never* vice versa. That is why it is super important to publish your ideas and creations and expose them as widely as you possibly can.

You should have one and only one defense against getting ripped off in any royalty setup – the expectation that you will be delivering newer and better stuff in the future. That's all.

(E) Apply the *shotgun* technique. There is no way that one single idea or product will hack it. To survive in this game, you'll need hundreds or even thousands of new ideas and concepts working for you on a total lifetime and total lifestyle basis. The

chances are that one or two genuine winners will pay for all the others lost or inevitably stolen.

(F) Be realistic. You do not create things to get filthy rich. Instead, you create things just because you like to create things and seem to have some compelling desire or need to do so. As long as there are still enough nickels to keep you going, that's all that really should matter.

### This Month's Contest

For this month's contest, just tell me a patent horror story that involves an individual or a small scale startup. There will be one dozen of my newly republished *Incredible Secret Money Machine II* book prizes awarded to the best, along with an all expense paid (FOB Thatcher, AZ) *tinaja quest* for two going to the very best of all.

As usual, send your entries to me here at *Synergetics* and not to *Nuts & Volts* editorial. Let's hear from you.

### For More Info

Two more *GENie* PSRT files about patents are my #477 NOPATENT.PS or #162 NOPATENT.TXT. And, of course, the "full set of plans" appears in my revised and updated *Incredible Secret Money Machine II*, available to you per my nearby *Synergetics* ad.

At this writing, an attempt is being made to convert the patent system into a "first to file" fiasco. Otherwise known as the *Patent attorney and patent examiner's relief act of 1993*. I am very much in favor of this legislation in that it will once and for all stamp out any remaining vestige of credibility of the US patent system, at long last revealing it for the utter ripoff it is for virtually all individuals and smaller scale startups. ♦

---

*Microcomputer pioneer and guru Don Lancaster is the author of 28 books and countless articles. Don maintains his no-charge tech helpline found at (602) 428-4073, besides offering all of his own books, reprints, and all of his consulting services. He also has a free brochure full of his resource secrets waiting for you. Your best calling times are 8-5 on weekdays, Mountain Standard Time.*

*Don is now the sysop of GENie PSRT, where a special Resource Bin topic has been reserved for Nuts & Volts readers. You can contact GENie at (800) 638-9636 (voice) for connect info. Or you can reach Don at Synergetics, Box 809, Thatcher, AZ 85552.*

# Patently Horrible

This month, I thought I might reach on down into my overflowing *patent victim* files and pull out several real-life horror stories of Midnight Engineers, some ordinary people, and other small scale startups who have been badly done in by the US patent system.

As we have seen in previous columns, the key problem here is the outrageous and dead-wrong popular mythology now surrounding patents and patenting. For most Midnight Engineers, patents become a costly and an easily avoidable sideshow that is virtually certain to result in a net loss of time, energy, money, and sanity.

The stories that follow are all real, typical, and accurate. I did adjust the scenery a tad to protect the guilty...

## The Solar Burn

Zack, a highly creative guy in New Mexico's Mimbres valley came up with an improved solar tracking device. He started building these and successfully selling them locally. Eventually he got a patent.

A somewhat less innovative individual across the street stole the plans and started selling carbon copies.

This didn't sit too well with Zack, so he stormed off to the Sheriff's office demanding that he "Arrest that crook". The Sheriff pointed out that there was no real criminal act involved as far as he could see. Besides, "that crook" was the Sheriff's brother-in-law.

Zack tromped off to his attorney, who pointed out that getting a patent was simply the first small step in a long, risky, and an unbearably expensive process. The next step would be the dispositions and case studies to determine the feasibility of a preliminary attempt at beginning to institute civil proceedings. Zack went bankrupt.

*Key points: (1) A patent is only the right to sue someone. (2) The time, cost, and energy of getting a patent is utterly negligible compared to the time, cost, and energy needed to maintain and defend that patent.*

## A Contest Winner

I recently ran a pair of contests in my *Resource Bin* column over in *Nuts & Volts*. Entrants could show that they profited from the patent system as an individual or small scale startup. Or else tell me a horror story of how bad the patent system did them in.

Despite attractive *Incredible Secret Money Machine II* prizes and shooting-fish-in-a-barrel odds of winning, there was only one entrant who claimed to profit from the patent system. He worked for a Fortune 500 copier company and

received several hundred dollars for an idea that the firm made millions on. After, of course, laying him off.

There were hundreds of horror stories submitted. Here's an excerpt from the *tinaja quest* grand prize winner...

Trompe Incorporated was a small manufacturer in the traffic safety field. They were an early leader in intelligent traffic light controls. They patented their design ideas. An Oregon firm simply stole their printed circuit board layouts outright, not even bothering to remove Trompe's copyright notices. They used these in their own products. Which, of course, were cheaper since there were no engineering costs or testing expenses to amortize.

Trompe sued in a lengthy and drawn out court process. Eventually, a cease and desist order was issued without any financial return to Trompe.

In response to the "cease and desist" order, the Oregon firm simply shut down and then reopened across the street using a new name. Still, of course, selling the exact same pirated clones. Changing the firm name reset to zero.

Court costs also bankrupted Trompe.

*Key points: (3) If your idea is any good, it will be stolen. Period. (4) Each patent violation is normally handled on an individual basis. If you do not know and cannot prove that someone is in violation, you have no redress. (5) The only three possible responses to a "You are violating my patent" letter are to ignore the letter, to bust the patent, or to obsolete their technology. The letter also converts what should have been your best customer into one irate and highly motivated enemy dedicated to doing you in.*

## The Grand Duchy of Fenwick

At one time long ago and far away, ultrasonic Doppler burglar alarms were a major technical breakthrough. They were the first to allow economic hands-off remote sensing of a protected area.

Jim honchoed a small and high energy Wisconsin hobby kit supply house. He very much wanted to offer a low cost Doppler alarm kit. But the Fortune 500 Granfallon that held the key patent flat out refused to even discuss licensing. On any terms whatsoever.

It turned out that "no" just was not in Jim's vocabulary. So Jim started a major program to bust the patent. For a while, he didn't get very far.

Until he went on his European vacation.

Jim just happened to be wandering through a castle in the Grand Duchy of Fenwick. There, just above the stairs to the dungeon, was a little handcrafted box with two small

microphones on it. Jim found this kinda curious and was told that Sven the old watchmaker down the street had been building these for years.

Jim met with Sven. Sure enough, the concept for their patent appeared to have been copied outright from Sven's designs. Jim gleefully went ahead and offered his new kits. They appeared in the leading hobby magazine of the time and were a stunning success.

When the gaggle of irate lawyers inevitably appeared on Jim's doorstep, they were given a choice. They could either go crawl back under the rock they came from or lose their patent. The choice was theirs.

*Key points: (6) There is not one patent in a thousand that cannot be busted outright or at the very least severely diminished by a diligent enough search for prior art in obscure enough places. (7) You don't need any prior art to bust a patent. All you have to do is show that it would have been reasonably obvious to a "practitioner in the field". (8) All it really takes to bust any patent is to show a failure to disclose. If there is anything anywhere they neglected to mention, their patent can be declared invalid. Under patent law, ignorance is not a legally defensible excuse.*

### The Night the Music Died

One "must read" for any Midnight Engineer is Jerome Markowitz's *Trials and Triumphs of an Organ Builder*. It is stocked by the *Vox Humana Press* at (215) 966-2200.

Jerome is the head honcho of *Allen Organ*, a family firm with a long history of combining traditional Pennsylvania Dutch craftsmanship with outstanding technical innovation. Allen's big thing has been to produce a superb pipe organ sound electronically. Complete down to individual voicing (each note separate), keying transients (chiff) and air flow variations (electronic whind).

Way on back before there was any modern electronic music, Allen teamed up with Rockwell International to develop the very first music synthesizer chips. They did so years ahead of anyone else and came up with what should have been the key patents for all synthesized sounds. And the basis for a major new US industry.

They did in fact come up with some complex LSI boards that formed the very first digital music synthesizer.

As Allen tells it, apparently a middle management type at Rockwell felt slighted and started a personal vendetta to crush the patent. He did this mostly by running around to other companies and then using that old "Let's you and him fight" ploy.

Sure enough, Allen was taken to court. They lost and appealed. They lost again and appealed. Allen then spent lots of time and effort getting an airtight case defending a rock solid patent. On third appeal, impeccable arguments were in fact presented. But an incompetent judge gave the jury instructions that were flat out wrong. Allen lost again.

That was the night the music died. The rest, as they say, is history. Japanese history.

*Key points: (8) Anyone that wants to can use the patent system to cause you no end of grief. (9) No matter how solid the case or how much time and energy you spend, patent law can and will easily turn against you. In fact, it is almost certain to do so.*

### Ignoring Sallen and Key

I got a patent in the mail the other day. The patentee was complaining that he was having trouble selling his idea. It seemed nobody was in the least interested.

The patent involved "a way to replace capacitors". The patentee felt that the big old air variable capacitors in older radios seemed large and hard to electrically adjust. So he promptly patented his new solution. *Without any testing or development at all!* He made no attempt whatsoever to investigate the long standard alternates of varactor diodes, digital synthesis, and surface wave devices.

Instead, he combined active filters using a "twin tee" op amp circuit that used photoresistors. Light shining on the sensors would be used for active tuning. There are bunches of obvious problems with this approach. The unstable and inefficient twin tee was shot out of the saddle in 1957 by Sallen and Key's "horses mouth" paper that became the cornerstone of the entire active filter technology.

Most active filters to this day are still too noisy and too instable for direct use as radio receiver front ends. Among other places, my 1975 *Active Filter Cookbook* talks about electronic tuning options. His opto coupling can introduce nonlinearities and instabilities precisely where you do not want them. High continuous power is required to keep the light shining in what is purportedly a micropower ap. And the issue of precisely stabilizing the light intensity for good tuning accuracy isn't even addressed.

His patent was a totally obvious and horrendously bad non-solution to a non-problem.

It wasn't even wrong.

*Key points: (10) Back in the golden age of inventing, ideas used to be worth as much as a dime a dozen. These days, they are worth less than ten cents a bale in hundred bale lots. (11) There is no point whatsoever in creating anything in any field in which you are not already a knowledgeable industry insider and capable of eventually becoming a guru or expert. (12) There is not one patent in one hundred that ever generates any net positive cash flow. With the poorly researched and undeveloped patents from any individuals outside of their field of expertise, the odds of any profits vanish entirely. (13) Large companies very rarely buy ideas or concepts. In fact, they studiously avoid doing so because of the risks, uncertainties, and liabilities involved. (14) A typical smaller manufacturer just couldn't care less about buying ideas or sheets of paper that say "patent" on them. What they'll seek out instead is the solid risk reduction offered by your expertise; your working prototypes in or beyond an advanced beta testing; and your ready-to-use production artwork.*

### The Little Engine That Couldn't

Take some off-the-shelf parts from *Radio Shack* and the local plumbing supply. Bolt them together to produce a clearly working model of an "energy recovery device". Sail through the patent process and quickly secure your patent. Instantly impress friends, neighbors, promoters, and even bureaucrats. Start winning "best of show" awards at all of your regional inventor's fairs.

What could possibly go wrong?

...go wrong?

...εο μλουε;

---

On a closer look, we have an irreversible thermodynamic process improperly coupled to a highly inefficient E-field machine. Being run beyond its self-destruct temperature. While generating trivial quantities of electricity in a largely useless form. Not to mention blatant violations of *dozens* of those fundamental principles behind physics, electronics, economics, and thermodynamics.

Yes, the device works. But its efficiency is ludicrously low. Insanely below that required for economic breakeven, let alone profitably recovering any nickel-per-kilowatt hour "avoided cost" electricity.

In fact, I found the theoretical efficiency to be so awful that selling the product could easily lead to prosecution for criminal fraud. As an outright scam.

The patentee did admit that he lived in an a "remote area" and "just couldn't find anything" on the topic of heat engines. Which, of course, is *the* single subject that more words have been written and more engineering manhours have been spent over a longer time than *any* other technical topic. The key thermodynamic reversibility issue here was first brilliantly resolved by James Watt. In 1784.

Five minutes with any mechanical engineer should have revealed that useful heat engines *must* at least approach full reversibility. And five minutes with an electronics engineer would have revealed that there *never* has been *any* E-field machine generate power at commercially viable rates.

*Key points: (15) Do all your homework! (16) Others are absolutely certain to have worked on and published related material. Failure to fully research all the prior art is sheer lunacy. (17) The patent system itself is the last place you want to look for prior art. Instead, over 95% of your time and effort should be spent with the industry trade journals, associations, trade shows, talking to knowing insiders, and through Dialog (415) 858-2700 and similar data bases.*

### **For More Info**

The really sad part of all these stories are these common underlying themes: Major opportunities lost and marketing windows forever slammed shut. Totally absurd mistakes made in utterly unrealistic quests. Time and energy blown on psychic energy sinks, legal hassles, and all-around bad vibes. Time that would best have been spent on developing and improving your products.

Or just plain having fun.

I've gathered together some reprints on patent resources, perils, and opportunities in my brand new *Case Against Patents* info pack. Much of this material is also available electronically on *GENie* PSRT. ♦

---

*Microcomputer pioneer and guru Don Lancaster is the author of 28 books and countless articles. Don maintains a no-charge technical helpline you'll find at (602) 428-4073, besides offering all his own books, reprints, and various services. Don has a free brochure chock full of his latest insider desktop publishing secrets waiting for you. The best calling times are 8-5 weekdays, Mountain Standard Time.*

*Don is also the sysop of GENie PSRT where a special area has been set aside for all you Midnight Engineering readers. For modem access, dial (800) 638-8369. Then enter HHH followed by XTX99005,SCRIPT. Or you could reach Don at Synergetics, Box 809, Thatcher, AZ 85552.*





# When to Patent

**F**or most of you Midnight Engineers and other small scale startups most of the time, any involvement whatsoever with the patent system is nearly certain to result in a net loss of time, energy, money, and sanity.

Two major reasons patents are usually an irrelevant and a totally unneeded sideshow: The outrageously dead wrong popular mythology that often will surround patents and patenting. And the ripoffs and outright scams which are *certain* any time an "inventor" context appears.

But – *extremely rarely* – I do get a helpline call from some Midnight Engineer who just possibly *might* want to look further into patents. One involved a new microscope. A second was a unique tunable laser.

It seems to me that there are some fundamental questions you should ask yourself before you so much as *think* about the word "patent"...

## Are you an industry insider?

Do you aggressively subscribe to most of the industry trade journals? Attend the major trade conferences? Talk to the real experts? Do you *thoroughly* understand all of the theoretical fundamentals behind the field? Are you aware of the political, legal, distribution, and marketing realities of the target industry? Do you know and understand the motives and desires of the industry's customers?

If not, the gotchas are near certain to git ya. If you are not an insider, the odds are overwhelming that you'll be working on some totally unmarketable non-solution to a non-problem. One with near-zero chances for success.

And one largely pointless to patent.

## Is the concept truly and genuinely new?

To be patentable, a concept must be *new*. It must not be obvious to *any* practitioner in the field. There must be no prior art *anywhere* in the world. Even in ultra-obscure and limited distribution documents. All prior art *must* be fully disclosed. Failure to disclose trashes the patent.

Because so many people are thinking about so many things in so many places, *synchronicity* virtually guarantees that your idea or concept is neither new nor unique. In fact, your idea almost certainly has been plowed over decades ago. To the point where *there is not one patent in one thousand that cannot be busted by a diligent enough search for prior art in obscure enough places*.

The only exceptions here are if you have a totally unique lifestyle, tools, and mindset. And have made the total personal commitment to being well *beyond* the bleeding edge of the technology in your target field.

## Have you done your homework?

At least 95 percent of your search for prior art should take place *outside* of the patent system. For the real world is where things actually get used by real people.

Have you *thoroughly* reviewed the trade journals, data books, industry shows, scholarly pubs, and manufacturer's catalogs? One recent helpline caller was trying to patent a widely advertised envelope design that was a 25 year old off-the-shelf item from one of the highest profile suppliers.

My long term favorite key research tools include the *Ulrich's Periodicals Dictionary* that lists some 150,000 trade journals. And the *Encyclopedia of Associations* that names just about every industry trade group.

But these days, your real research biggies are the online resources. Especially *Dialog* and the *Internet*. To the point where I very strongly feel that *it is virtually impossible to successfully patent something today without an extremely aggressive personal use of the on-line resources*.

Mindsets such as "But I live in a remote area", or "There is nothing in my local library" are *absolutely guaranteed* to cause your patent to fail.

## Have you done an economic analysis?

I have gotten dozens of helpline calls from potential patentees who have given no thought whatsoever to the needs and desires of the ultimate customers.

A surprisingly wide variety of products can be grossly classified as "toys" or "tools".

If it's a toy, how much time and effort is the end user willing to spend to derive pleasure from the toy? For how long? How well does that time and effort compare to the rewards for selecting a different toy instead?

If it's a tool, how long does it take the tool to pay for itself? The key issue here is finding the *time to economic breakeven*. Many tools will *never* pay for themselves. This happens if the initial cost and the time value of the money needed to buy them exceeds the net return in income or productivity the tool generates.

In one sad helpline case, a potential patentee had a product that would *at best* increase the direct mail response of non-profit organizations by a few hundredths of one percent. While creating high avoidable costs in the process. In another, a low temperature heat engine was so utterly inefficient that the longer you ran it, the more it cost.

Always place yourself in your customers shoes. And ask what the benefits are. Failing to do an economic analysis is sheer lunacy.

## Will your net sales exceed \$12,000,000.00?

What percentage of your profits are you willing to spend subsidizing the US patent system? Four percent? Forty percent? For some reason that I don't fully grasp, most patentees insist on spending between 400 and 4000 percent of their profits on patent office and attorney subsidies.

Sometimes much more.

Remember that a patent is *only* the right to sue someone. The cost of getting a patent is utterly trivial compared to your long term enforcement costs.

Let us assume you can get a patent and successfully defend it through a court challenge and an appeal or two for less than \$240,000. This figure is much *less* than the norm. Let's also assume you are willing to blow 25% of your profits on the patent system. Your profits would then have to be \$960,000. Assume further that your business has a net profit margin of 8 percent. A figure much *higher* than most industry averages. Your net sales would then have to exceed \$12,000,000.00 for a patent to just barely meet your subsidy goals.

To me, it makes *no economic sense whatsoever* to try and patent a million dollar idea.

## Does the field welcome innovation?

Certain fields *severely* penalize any new products from Midnight Engineers or any unknown small scale startups. While making sure that they are virtually *certain* to be an economic failure. *If there are possibly insurmountable marketing hurdles in the target field, there is not much point in worrying about patents.*

At least until such time as you are reasonably sure the hurdles can be successfully cleared.

Some ferinstances: Products that are legislated to death (cancer cures; cryptography). Highly regulated industries (pollution controls; industrial safety). Overpriced solutions for ill-defined markets (handicapped).

Designs that demand a new infrastructure (electric cars). Or threaten an old infrastructure (electric cars again).

Unpatentable pseudoscience areas that previous scams have trashed (cold fusion; perpetual motion). Fields that have been eaten for breakfast by lawyers (private aviation; sports gear). Or ventures where some elite oligopoly calls all the shots (long distance telephony).

Two of the most restrictive markets are autos and private aviation. Primary automotive is a closed club. If you, your father, and your grandfather are not all SAE members, you can forget it. Aftermarket automotive has such gotchas as the EPA making it is a felony to *reduce* emissions on a car when you modify an emission control device.

The private aviation market is simply not there. A glance at any rural airport verifies this. As does the fact that the leading business jet sold a mere *fourteen* copies last year. Your best bet is to take your quarter size working model and sell it to the wide open and highly lucrative R/C model field instead. Go where you're wanted.

## Will only a few covet your design?

Patents are enforceable only where and when you're able to clearly identify a few major violators. Each offender usually has to be dealt with individually.

Suppose you patent something and nobody bothers to

challenge it in any manner. Which is the fate of the vast majority of patent submissions. Clearly your idea was not worth patenting in the first place.

On the other hand, suppose instead *everybody* covets your patent. There is *still* no way you can enforce it.

One way this happens is when the idea is so obvious that nearly anyone can grab and use it. Such as new data sorting or compression methods. Another way is if the idea is so good and so important that the rest of the world flat out won't sit still for paying any royalties.

Two specific examples: RCA owns the iron-clad patent on making characters out of dots on a video screen. And Photocircuits now owns the rock-solid patent on printed circuits. As far as I know, neither company has been able to collect one red cent of royalties on these.

Because these ideas were *so good* that they simply *had* to be stolen.

Even the *threat* of a "too good" patent will immediately be met with an big bucks industry-wide response. Witness Compton's trying to patent Hypercard years after the fact. And, for the attempt, deservedly getting spanked and sent to bed without any supper.

An ideal example of an enforceable patent would be something like a down-hole oil recovery device. That, as an unavoidable side effect, left traces of a benign but exotic isotope in the refined gasoline. Only a few (the major oil companies) would be in a position to rip you off. And it would be clearly obvious who they were.

## Is there Fortune 500 involvement?

These days, most patents are largely by, for, and of the megacorporations. Who have their legal departments to make patents solid and defendable. Plus the time and patience to pursue them. And are able to creatively bury the high hidden costs and negative vibes of patenting. A case can be made that the only real use patents serve today is as high tech trading cards for corporate power plays.

Larger investors also tend to favor patents. Under the delusion that they in some manner offer "protection" for their investment. In reality, most of the time, excessive patent involvement acts only as a long term cash drain.

Thus, the larger the company, the higher the *perceived* value of patent portfolios. But perception is not reality.

On the other hand, I have personally found that *any* involvement with Fortune 500 biggies will often do you in very badly. In totally unexpected ways. Much more on this in my *Incredible Secret Money Machine II*.

## Will your product last five years?

Typically, it takes a year to two to get a patent. And you will need several more years after that to generate the cash flow to pay for your patent involvement. Some products do have rather long potential lifetimes.

Others do not.

Obviously, computers, electronics, and multimedia are fields where things are coming down so fast that most products are effectively obsoleted in six months. A time frame so tight that most competitors will elect to obsolete your product rather than copy it. *The surest way to render a patent moot is to improve it.*

It is not at all clear to me what role patents can serve in rapidly changing technologies.

---

## Is your product in beta test?

Any concept must follow a very steep *idea mortality curve*. As the idea moves from concept through evaluation, design, analysis, beta test, and final out-the-door products. Typically, 499 out of 500 concepts fail.

The further to the right you move along the curve, the *higher* your odds of success. And the *lower* the risk to the ultimate seller. Ideas themselves used to be worth a dime a dozen. These days, they are worth less than a dime a bale in 10 bale lots. Ideas gain value *only* as they progressively move along the mortality curve.

A near final step in the curve is the *Beta Test*, where outsiders are thoroughly evaluating your pre-production prototypes. A "patent without a model" is totally ludicrous (and wholly unmarketable), since you *must* have *many* models to get through this essential final hurdle.

*Until you get out of Beta Test, you have absolutely zilch.*

## Is this what you really want?

A poet once spoke of a fork in the woods as the *path not taken*. When you pick the patent route, you largely commit yourself to a lifetime of courtrooms, bureaucratic hassles, stress, hidden agendas, attorney's, and dispositions. And adversarial relationships that quickly convert your potential best customers into lifetime enemies devoted to doing you in. All at a monumental price in lost time and energy. With very low odds of a long term positive return.

When you pick the "tell all; hit it hard; then get out" non-patent route, you instead spend your time in your lab profitably developing, testing and improving new products instead. On a friendly and sharing basis with your best present and future customers.

Which path is more suitable for you?

## For more information

Much more on tested and proven alternatives to patents and patenting does appear in my *Case Against Patents* information package. *Ulrich's* and the *Encyclopedia of Associations* should be available online or on the reference shelf of your nearby library. *Dialog* is offered via many commercial online services. Call them at (415) 858-2700 for a brochure.

More info on the idea mortality curve in [RISKDOWN.PS](#) on my [www.tinaja.com](http://www.tinaja.com). Additional materials on patents and patenting in general is found on the *Patent Avoidance* library shelf. Also at [www.tinaja.com](http://www.tinaja.com).

Let's hear from you. ♦

---

*Microcomputer pioneer and guru Don Lancaster is the author of 33 books and countless articles. Don maintains a US technical helpline you'll find at (520) 428-4073, besides offering all his own books, reprints and various services.*

*Time and funding constraints strictly limit this service to US callers only.*

*Don has a free new catalog crammed full of his latest insider secrets waiting for you. Your best calling times are 8-5 weekdays, Mountain Standard Time.*

*Don is also the webmaster of [www.tinaja.com](http://www.tinaja.com) where a special area has been set aside for Midnight Engineering readers. You can also reach Don at Synergetics, Box 809, Thatcher, AZ 85552. Or email [don@tinaja.com](mailto:don@tinaja.com)*



Finding rms voltages  
 Pager motor vibrators  
 A superb color printer  
 New patent repository  
 PostScript as language

The folks at IBM have added a new patent repository to the web. With a free searchable master file for all patents in all fields newer than 1971. Plus a \$3 per patent hard copy fax service. You can access this site from the [Patent Avoidance Library Shelf](#) page of my [www.tinaja.com](http://www.tinaja.com) Or reach it directly at <http://patent.womplex.ibm.com>

This new service certainly is fast, convenient, and scads of fun to play with. Text and complete figures are included. As are "forward looking" cross references. The site is not yet in *Adobe Acrobat*, so the figures remain somewhat grubby looking. And I feel their search engine seems to be a tad on the weak side.

But do note that not one patent in 200 ever shows any net positive cash flow. Less than one patent in 1000 is ever "new" enough or "non-obvious" enough that it cannot get busted with a thorough enough search for prior art in obscure enough places.

Thus, any patent repository might *overwhelmingly* end up providing a mind-numbing stash of incompetent failures and total losers. An amazing number of patents just plain *do not work*. Your effort is infinitely better spent studying the trade journals and all of the web sites where the winners consistently appear.

For instance, I was two for two on my first visit here. I looked into two patents and now have a pair of superb new candidates for my patent horror story collection. I first searched on "ac phase control" to find out where it would end up leading me.

The first patent from 1992 looked vaguely familiar. Sure enough, I had published the *exact* same waveforms back in the September 1969 *Popular Electronics*. On page 30.

While studiously ignoring obvious high profile public domain prior art, they did, of course, manage to make their design far more complex and way more expensive than necessary.

The second patent was more recent. And even sadder. They started with a 1938 construction project you

can locate in *Radio News* that talked about what was then referred to as a *Thyratron half wave proportional ac power control*.

A fine subject that later became a mainstay chapter in most industrial electronics books of the 1940's. As further claims, they then added some wishful thinking which was not even wrong. Wishful thinking that *every* intro circuit theory book warns you about. In bold print. Sigh.

More on patent horror stories in [PATNTHOR.PDF](#). A reality checklist of the scant few times when a patent *might* be appropriate can be found in [WHEN2PAT.PDF](#). Tested and proven

alternatives to patents and patenting are provided in my [The Case Against Patents](#) package from *Synergetics*.

### A Superb New Printer

I've long been searching for a cost effective way to do high quality, full color covers for my [Book-on-demand](#) publishing. There is now this utterly amazing new MD-2010 printer from *Alps* that fills the bill beautifully. At a street price as low as \$390.

This is a letter to legal size dye sub printer. Their *micro-dry* inks arrive on ribbons. Usually in photo realistic black, cyan, magenta, and a yellow. But optionally in *metallic foil* gold,

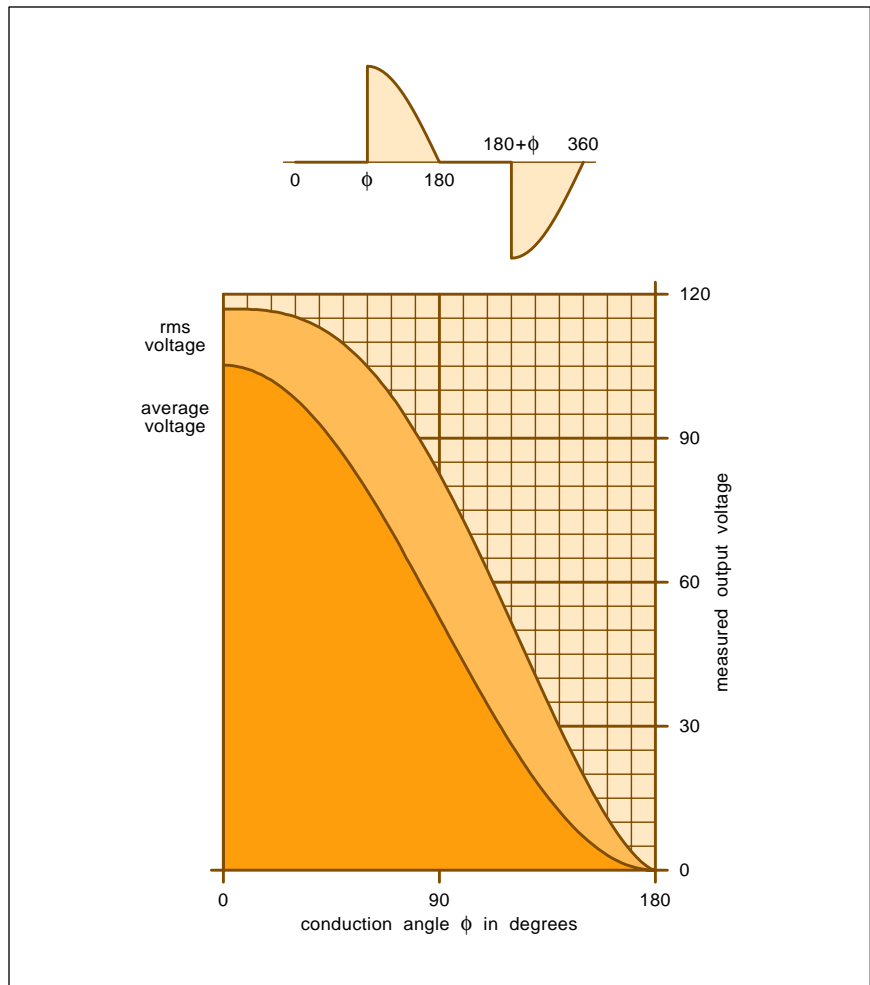

Fig. 1 – HOW THE RMS AND AVERAGE voltages for a line operated full wave triac phase control vary with conduction angle.



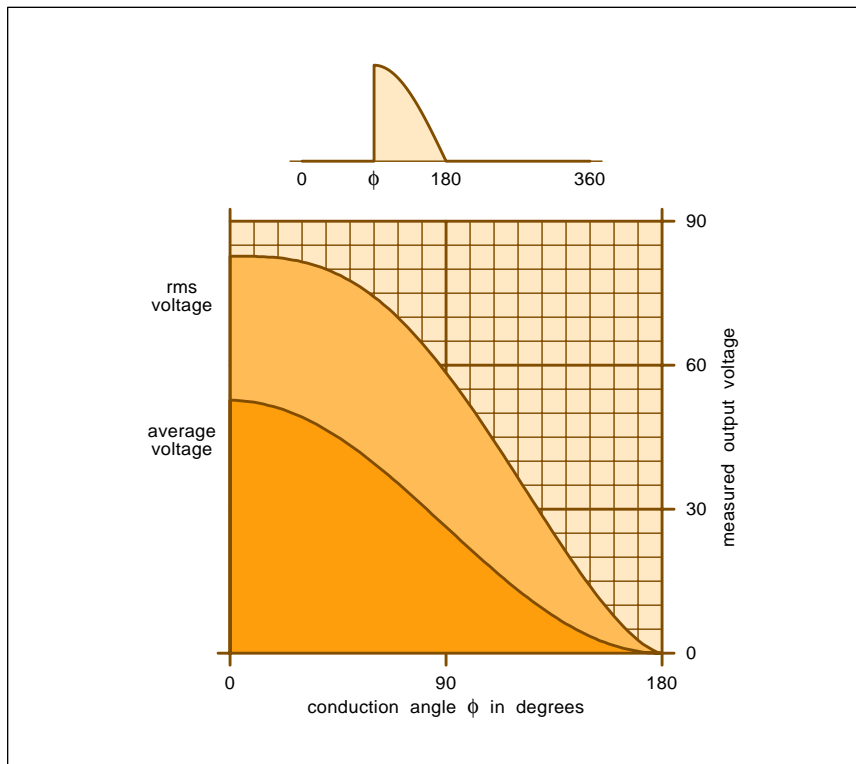

Fig. 2 – THE RMS AND AVERAGE voltages for an ac line operated half wave thyatron phase control. This circuit is obsolete and should no longer be used. Because it tries to draw direct current from the ac power line.

silver, and cyan. Along with a regular black. Thus, you can easily do *Kroy Color* and hot-stamp effects with this machine. The output quality has to be seen to be believed. Final prints are water resistant. Optional materials let you handle T-shirt, mug, and printed circuit transfers. By use of iron-on transfers and back print stocks.

Their back print stock gives you a way to produce glossy "photos". You auto print reversed left-to-right on to this transfer sheet. And then iron the stock onto your final page.

The carrier sheet then gets peeled away, leaving you a protected glossy photo effect.

Your typical setup is an 8 Meg or higher Windows 95 host with a high speed bidirectional parallel port. A fancy and custom menu-driven print driver software is included.

This Alps MD2010 is rather well suited to point-of-purchase messages, greeting cards, table tents, badges, and high quality business cards. And plenty of full color fill-a-local-need specialty items. Stuff you can easily make a buck on.

The printer does not directly speak

PostScript. At least not yet. But you can easily print PostScript files with the MD-2010. Either with *GhostScript* host shareware or by using the .PDF format of *Adobe Acrobat*. A while back, I wrote a [COLORIZ2.PS](#) routine which converts older B/W PostScript grays into color tints for web display. Amazingly, this same routine works well on the MD-2010. It invisibly and automatically takes care of the color separations for you!

A stripped down CD version of *Adobe PhotoShop* they named *Photo Deluxe* is included with the printer.

Their printer works on a multiple pass basis, grabbing one ribbon at a time. It sure is fun watching those color separations getting built up into a final print. Because the ribbons are bar coded, any ribbon can go in any slot. But do make sure they are right side up. And be certain to verify the anti-curling bar is completely to the left when you close the lid.

Alps claims a 14 cent per page cost for ribbons. This assumes a "normal" business letter and letterhead with a scant five percent coverage of each color. This price per page is based on

\$6 ribbons. Costs should drop when third party bulk ribbons and greatly improved prices appear in *Recharger* magazine and similar sources.

Because of denser coverage, any typical book cover ribbon cost might price out more like 40 cents or more. Worst case, a full page and full color print could exceed several dollars a copy. Plus scrap and testing.

The Alps machine can print up to a 8 x 13.5 inch active area on most any 8.5 x 14 legal sheet. This translates to a book cover that can be over eight inches high and nearly seven inches wide. Minus bleeds and trims.

My *Active Filter Cookbook* is 5-1/2 inches wide by 8-1/2 high.

There is a "cardboard" mode that handles papers up to ten mils thick. But a better alternative is to print up your cover on a high quality thinner paper and thicken it by using a white self-stick label backing. Giving you a heavy weight and the "duplex stock" effect of a fully professional cover.

Either back print stock or optional lamination can be used for extra scuff resistance. I personally prefer the low gloss and "lay flat" materials.

More on all these binding topics in [EMERGOP5.PDF](#).

As a tradeoff for their low cost and high print quality, their speed here is best described as "not quite glacial". For instance, last month's six page column of [MUSE112.PDF](#) will print in B/W at 360 copies per hour on my 5SiMx. In color with host PostScript, the MD2010 just barely manages 3 or so copies per hour.

Speed should improve when their internal PostScript upgrade is added. At present, this printer is clearly *not* suitable for online network printing. And probably is not your best choice as your first and only printer.

The print quality on a light beige is outstanding. But I found a very slight patterning on a blue-green tint. Thus, certain light shades often print better than others. I also found their greens wandering off somewhat too far into the blue. For BOD covers, you might want to adjust the colors to suit what the printer does best.

My [MUSE112.PDF](#) makes a fairly useful PostScript printer demo. I've also uploaded a new sample test BOD cover as [ACTIVCOV.PDF](#). More on BODsecrets in my *Book-on-demand*

*Resource Kit* and on the BOD library shelf of [www.tinaja.com](http://www.tinaja.com)

You'll also find a MD-4000 version that includes a built-in scanner. The Alps website is [www.alps.com](http://www.alps.com)

### PostScript as Language

I have always felt that PostScript is an absolutely outstanding and general purpose computer language. One that I use for nearly all of my design and development work.

I have recently used PostScript for everything from my magic sinewave synthesis to web site hit analysis to Smith Chart rf generators to printed circuit layouts to robotics controllers to stock market tracking.

Some exciting things have recently happened that make PostScript even more attractive and easier to use.

For instance, *Adobe Acrobat* is now fully web friendly. An *Adobe Access* opens up resources for the disabled. GhostScript shareware gives you one powerful and flexible host located equivalent to display PostScript. The *Videonics* folks now have PostScript *video* apps. And my *Flutterwumper* techniques extend PostScript to cost effective robotics.

But the really neat new trick is that the Distiller in Adobe Acrobat is also a fast and easy way to do host based PostScript computing! Their Distiller produces printable output files, reads or writes disk data files, or returns recordable data to its log file. Making it fast and fun to explore PostScript as language. Without even needing a PostScript printer.

If you are using Adobe Distiller as a PostScript-as-language computer, note that the results are written to the .LOG file, rather than your .PDF file. You will often throw away the baby and drink the washwater instead.

More info on PostScript in the "red book" *PostScript Reference Manual* and "blue book" *PostScript Tutorial*.

Additional info on the PostScript library page of [www.tinaja.com](http://www.tinaja.com)

### Finding RMS Currents

A typical example of what you can do when using PostScript as language appears in Listing one. This lets you find the rms and average values for any waveform. It accepts an array of amplitudes as an input. These values can be mathematically determined or

```
% POSTSCRIPT RMS VALUE FINDER
% =====
% Copyright c 1997 by Don Lancaster and Synergetics, Box 809,
% Thatcher AZ, 85552. (520) 428-4073 www.tinaja.com don@tinaja.com
% All commercial rights and all electronic media rights are
% *fully* reserved. Linking welcome. Reposting expressly forbidden.
% =====

% Consulting services available on concepts shown.
% Two-way recordable comm is **REQUIRED** for these utilities.

% Routines excerpted from FINDRMS.PS on www.tinaja.com...

/scaleamp 117 2 sqrt mul def % use a 117 volt ac cycle
/startang 0 def % set limits
/stopang 180 def %
/engang 180 def %
/res 0.1 def % step resolution in degrees

% Assume a ONE OHM load. Make a normalized array holding the desired
% waveform values. This routine optimizes for ac phase control.
% Any values array normalized to peak = 1 can be substituted...

/makewaveform {/waveform mark 0 res engang {/ang exch store ang
startang gt ang stopang lt and {ang sin} {0} ifelse} for] def } def

% do the rms and average calculations on the waveform array...

/findrms1 { 0 waveform {add } forall waveform length div
/normaverage exch store 0 waveform {dup mul add} forall waveform
length div sqrt /normrms exch store normrms normaverage dup 0 eq
{pop 0.000001} if div /normratio exch store} def

% report the results...

/crlf true def % IBM or sanity?
/return {(x) print crlf {(n) print} if} def

/reportrms {return return (The average normalized waveform value is
) print normaverage 20 string cvs print return return
(The rms normalized waveform value is ) print normrms 20 string cvs
print (.) print return
(The ratio of rms to average is ) print normratio 20 string cvs
print (.) print return return
(The average scaled waveform value is ) print normaverage scaleamp
mul 20 string cvs print (.) print return return
(The rms scaled waveform value is ) print normrms scaleamp mul 20
string cvs print (.) print return return return} def

/findrms {findrms1 reportrms} def % convenience linker

% ===== demo - remove or alter before reuse. =====
% (A) Plot the rms voltage versus phase angle for a triac that
% conducts only a portion of each ac half cycle

/res 0.1 def % 0.1 degree accuracy
/startang 0 def % start at turnon angle
/stopang 180 def % go to the end of half cycle
/engang 180 def % stop at one half ac cycle
/scaleamp 117 2 sqrt mul def % use a 117 volt ac cycle

0 10 180 { /startang exch store (The phase angle is ) print startang
20 string cvs print ( degrees.) print return makewaveform findrms}
for flush

% should return these edited results...

%% The phase angle is 0 degrees.
%% The rms voltage is 117.0.
%% The ratio of rms to average is 1.11072.

%% The phase angle is 10 degrees.
%% The rms voltage is 116.936.
%% The ratio of rms to average is 1.11852.

<< more stuff here >>

%% The phase angle is 170 degrees.
%% The rms voltage is 3.94639.
%% The ratio of rms to average is 4.88476.

%% The phase angle is 180 degrees.
%% The rms voltage is 0.0.
%% The ratio of rms to average is undefined.
```

Listing 1 – RMS AND AVERAGE voltages or currents for any waveform can be easily found using this powerful PostScript-as-language routine.

PAGER VIBRATOR RESOURCES

**Cellular Business**  
9800 Metcalf  
Overland Park KS 66212  
(913) 341-1300

**Endicott Coil**  
24 Charlotte Street  
Binghamton NY 13905  
(607) 797-1263

**The Mart**  
899 Presidential #110  
Richardson TX 75081  
(800) 864-1155

**Micro Mo Electronics**  
14881 Evergreen Avenue  
Clearwater FL 34622  
(813) 572-0131

**Mobile Radio Technology**  
9800 Metcalf  
Overland Park KS 66212  
(913) 341-1300

**Mondo-tronics**  
524 San Anselmo Ave #107  
San Anselmo CA 94960  
(800) 374-5764

**Motorola Comm Prods**  
1301 E Algonquin Road  
Schaumburg IL 60196  
(800) 668-6752

**Namiki**  
201 W Passaic Street  
Rochelle Park NJ 07662  
(201) 368-0123

**Pageco**  
2400 E Comm Blvd #630  
Ft Lauderdale FL 33308  
(954) 776-0031

**Robotics Digest**  
966 Elm Street  
Rocky Ford CO 81067  
(719) 254-4558

**Surplus Traders**  
PO Box 276  
Alburg VT 05440  
(514) 739-9328

**Telecom**  
1020 Church St  
Evanston IL 60201  
(847) 475-1900

experimentally lab measured.

This specific use example finds the rms and average voltage values of a full wave triac phase controller for various firing angles.

The data array gets normalized to unity peak amplitude. Every array value first gets squared and summed. Your result then gets divided by the number of samples to find your rms voltage or current. Although any reasonable number of array values can be used, a hundred to a thousand data points often gives you accurate results. And does so fairly quickly.

You could edit and send this code to any PostScript printer having two way recordable comm. Or route it to GhostScript. But best of all, feed it to Acrobat Distiller 3.0 for convenient and fast host-based computing.

The full wave results are shown in figure one. As we've seen before, the output rms voltage is nonlinear with phase angle. Caused by there being very little energy in the "ears" of a half sinewave.

As historical interest, I've included the old half wave "Thyratron" phase control response in figure two. This circuit became obsolete in the early sixties as full wave triacs and other solutions became practical.

Why? because of its limited range and its big no-no of drawing direct current out of the ac power line. As of July 1997, this circuit is illegal in Europe. Per EN60555. In the US, a similar IEEE 519 is pending.

The half wave circuit can conduct only on the positive cycles, so it can deliver only *one half* of the available power. Note that half power is 0.707 voltage on a sinewave, so your max

half wave rms voltage on a 117 volt line is 83 volts or so.

Also note how badly any average responding meter *under*-reports your system power. Most especially at low levels and late conduction angles. For instance, we see that at an angle of 125 degrees, the true rms voltage is 32, while a typical average meter will report 12 volts. An error of 267%.

Listing 1 and additional examples are available ready-to-use as my file [FINDRMS.PS](#), while your actual code used to generate figures one and two can be extracted from [MUSE113.PSL](#).

**Pager Vibrators**

This one sure hit me from way out in left field. There have been some recent helpline requests for more info on *pager vibrators*. Also called *pager motors*. Apparently there's a few new robotics or personal warning device possibilities for these.

My personal fire pager is older and lacks one of these, so I did not have a clue where to begin.

Some possibilities were *Mobile Radio Technology*, *Telecom* and *The Mart* magazines. A company called

*Endicott Coil* used to make keyboard clickers, but I have not checked into them recently. To attack the robotics angle, there is *Mondo-tronics* for the parts and *Robotics Digest* magazine for ads and tech info.

All of which seem somewhat short of the mark. These days, to pick up instant answers, you *always* go to the web. Start with the "search all sites" top button on my *Web Related Utility Links* page. Punch on down into *Alta Vista*, and then enter "pager vibrator" or "pager motor".

Presto. Instant results.

We find that *Namiki* is the leading manufacturer. A typical model is their 6CV-1501WL-00. This gem is six millimeters in diameter and only fifteen long. The 1.3 volt motor runs at 7000 rpm. Which translates to 116 whumps per second. A companion tungsten counterweight is included.

*Motorola* apparently uses *Namiki* pagers internally as their part number 5950-46803. A second pager vibrator supplier is *Micro-Mo*.

The net also tells us that these are a tad pricey, being something like \$17 in singles. One smaller quantity reseller is *PageCo*. *Surplus Traders* has these in huge quantities. But only on a when and as available basis.

A few of these useful pager motor contacts are shown in this month's resource sidebar. Be sure to tell me about any new uses you can come up with for these. Or if you find a super cheap source for them.

**Names & Numbers**

From *Maxim*, a new *Product Data Sheets CD*. *TriTech Microelectronics* has data sheets on several intriguing

**NEED HELP?**

Phone or write all your US Tech Musings questions to:

Don Lancaster  
Synergetics  
Box 809-EN  
Thatcher, AZ, 85552  
(520) 428-4073

US email: [don@tinaja.com](mailto:don@tinaja.com)  
Web page: [www.tinaja.com](http://www.tinaja.com)



**NAMES AND NUMBERS**

**Adobe Acrobat**  
1585 Charleston Rd  
Mountain View CA 94039  
(800) 833-6687

**Alps Electric**  
3553 North First Street  
San Jose CA 95134  
(408) 432-6000

**Antique Power**  
Box 838  
Yellow Springs OH 45387  
(937) 767-1433

**Cryptosystems Journal**  
485 Middle Holland Rd  
Holland PA 18966  
(215) 579-9888

**Damark**  
Box 29900  
Minneapolis MN 55429  
(800) 729-9000

**Machinery Dirs Natl Assn**  
1110 Spring Street  
Silver Spring MD 20910  
(301) 585-9494

**Magnetic Research**  
122 Bellevue Ave  
Butler NJ 07405  
(201) 838-6348

**Maxim**  
120 San Gabriel Dr  
Sunnyvale CA 94086  
(800) 998-8800

**Metal Buyers Mart**  
N15 W22218 Watertown Rd #3  
Waukesha WI 53186  
(800) 657-0721

**Ragtime**  
4218 Jessup #AB  
Ceres CA 95307  
(209) 668-0366

**Recharger**  
4218 W Charleston Blvd  
Las Vegas NV 89102  
(702) 438-5557

**Synergetics**  
Box 809  
Thatcher AZ 85552  
(520) 428-4073

**TelCom Semiconductor**  
1300 Terra Bella Avenue  
Mountain View CA 94043  
(415) 968-9241

**TriTech Micro**  
1440 McCandless Drive  
Milpitas CA 95035  
(800) 253-8900

**Videogame Advisor**  
64 Danbury Road Ste 500  
Wilton CT 06897  
(203) 761-6150

**Vision Systems Design**  
10 Tara Blvd 5th Floor  
Nashua NH 03062  
(603) 891-0123

new chips. Such as a TR88801CS pen input conditioner, a 89101 Caller ID interface, and their TR83100CF voice storage processor.

From *TelCom Semiconductor*, a *Thermal Management Guide*. On all of their electronic thermostats and temperature sensors.

Wireless remote game controllers are being distressed out by *Damark* at \$50 each. These would appear to offer all sorts of unusual short range data comm possibilities.

Player pianos are now fully MIDI compatible. For full details, you can contact the folks at *Ragtime*.

The great *Magnetic Measurements Handbook* has been newly revised by Jack Janicke of *Magnetic Research*. Plenty of fluxgate information here. Tony Patti has released his fourth volume of his ongoing self-published *CryptoSystems Journal*.

From *MDNA*, the *Used Machinery Buyers Guide*. For largish pieces of metal in smaller quantities, check out

the *Metal Buyers Mart*.

New trade journals for this month include *Vision Systems Design* and a *Videogame Advisor*.

If you are *really* into hardware, do look into *Antique Power* magazine. Mostly on restoring steam tractors.

Or their sister publication with the subtle name of *Old Truck*. There sure is some amazing stuff in both mags.

For the insider secrets of starting up your own technical venture, check my *Incredible Secret Money Machine II*. As per my nearby *Synergetics* ad. Also visit my *Guru's Lair* web site at [www.tinaja.com](http://www.tinaja.com) I have just added a mass teletyping update here as file [RESBN63.PDF](#). Plus font conversion tools [PFA2PFB.PS](#) and [PFB2PFA.PS](#).

Most items mentioned appear in the *Names & Numbers* or the *Pager Vibrator Resources* sidebars. Be sure to check here first before calling our no charge US technical helpline I've shown in the box.

Let's hear from you. ♦

**new from  
DON LANCASTER**

**ACTIVE FILTER COOKBOOK**

The sixteenth (!) printing of Don's bible on analog op-amp lowpass, bandpass, and highpass active filters. De-mystified instant designs. **\$28.50**

**CMOS AND TTL COOKBOOKS**

Millions of copies in print worldwide. THE two books for digital integrated circuit fundamentals. About as hands-on as you can get. **\$28.50** each.

**INCREDIBLE SECRET  
MONEY MACHINE II**

Updated 2nd edition of Don's classic on setting up your own technical or craft venture. **\$18.50**

**LANCASTER CLASSICS LIBRARY**

Don's best early stuff at a bargain price. Includes the CMOS Cookbook, The TTL Cookbook, Active Filter Cookbook, PostScript video, Case Against Patents, Incredible Secret Money Machine II, and Hardware Hacker II reprints. **\$119.50**

**LOTS OF OTHER GOODIES**

Tech Musings V or VI . . . . . \$24.50  
Ask the Guru I or II or III . . . . . \$24.50  
Hardware Hacker II, III or IV . . . . . \$24.50  
Micro Cookbook I . . . . . \$19.50  
PostScript Beginner Stuff . . . . . \$29.50  
PostScript Show and Tell . . . . . \$29.50  
Intro to PostScript Video . . . . . \$29.50  
PostScript Reference II . . . . . \$34.50  
PostScript Tutorial/Cookbook . . . . . \$22.50  
PostScript by Example . . . . . \$32.50  
Understanding PS Programming . . . . . \$29.50  
PostScript: A Visual Approach . . . . . \$22.50  
PostScript Program Design . . . . . \$24.50  
Thinking in PostScript . . . . . \$22.50  
LaserWriter Reference . . . . . \$19.50  
Type 1 Font Format . . . . . \$16.50  
Acrobat Reference . . . . . \$24.50  
Whole works (all PostScript) . . . . . \$380.00  
Technical Insider Secrets . . . . . **FREE**

**POSTSCRIPT SECRETS**

A Book/Disk combination crammed full of free fonts, insider resources, utilities, publications, workarounds, fontgrabbing, more. For most any PostScript printer. Mac or PC format. **\$29.50**

**BOOK-ON-DEMAND PUB KIT**

Ongoing details on Book-on-demand publishing, a new method of producing books only when and as ordered. Reprints, sources, samples. **\$39.50**

**THE CASE AGAINST PATENTS**

For most individuals, patents are virtually certain to result in a net loss of sanity, energy, time, and money. This reprint set shows you Don's tested and proven real-world alternatives. **28.50**

**BLATANT OPPORTUNIST I**

The reprints from all Don's Midnight Engineering columns. Includes a broad range of real world, proven coverage on small scale technical startup ventures. Stuff you can use right now. **\$24.50**

**RESOURCE BIN I**

A complete collection of all Don's Nuts & Volts columns to date, including a new index and his master names and numbers list. **\$24.50**

**FREE SAMPLES**

Check Don's Guru's Lair at <http://www.tinaja.com> for interactive catalogs and online samples of Don's unique products. Searchable reprints and reference resources, too. Tech help, hot links to cool sites, consultants. email: [don@tinaja.com](mailto:don@tinaja.com)

FREE US VOICE HELPLINE VISA/MC

**SYNERGETICS**  
Box 809-EN  
Thatcher, AZ 85552  
(520) 428-4073



by Don Lancaster

# Risk Reduction

You can call it *mythology* or *urban lore*, or anything you care to. But the quaint concept of "get an idea; patent it; and then beat the cash waving Fortune 500 companies back with a stick" is dead wrong. It simply has no rational basis in the real world.

Things flat out don't work that way. They never have. And almost certainly never will.

As we've seen lots of times before, perceiving yourself as an "inventor" and behaving like one is monumentally dumb. All this does is open yourself up to every ripoff and scam in the book. Plus a few that have not yet made print. Virtually guaranteeing you an uneven playing field. One that nearly always leads you to a net loss of time, money, energy, and sanity. Fer sure.

Instead, I'd like to share with you an alternate concept that has worked out quite well for me. And seems to work for the overwhelming majority of midnight engineers who have tried it and profited from it. The concept is this: You perceive yourself as a *purveyor of risk reduction*.

What this can do is completely inside out the problem. You ask yourself just why any manufacturing or marketing company would ever decide to pay you for anything. The obvious answer is that they should gladly pay you for just about anything which genuinely and truly (A) saves them time; (B) saves them money; (C) provides them with instant expertise; (D) increases the awareness and motivation of their customers; or otherwise (E) greatly improves the odds of their ongoing success.

Not only will they gladly pay you for those services, but they will most assuredly keep coming back to you. So long as they still retain the expectation that their involvement with you continues to save them time and money.

*And so long as you keep reducing their risks.*

As a purveyor of risk reduction, you can still do most of the things a mythical inventor would do. Except that you dramatically increase your odds of success. And distance yourself from all of the usual scams and ripoffs. What you are really doing is matching your activities to the way the real world works. And then finding those niche activities in which you can genuinely cause things to happen. With reasonable odds of actually turning a profit.

The trick is to position yourself so that you appear to be providing accepted and low key services in an apparently conventional and routine manner. And to break up your offerings into smaller and well-defined tasks.

The reason that being an inventor does not work and that being a purveyor of risk reduction does is very simple. It all gets based upon...

## The Idea Mortality Curve

Any raw idea always has a bunch of hurdles it has to get over to turn into a real world product. These hurdles are often called...

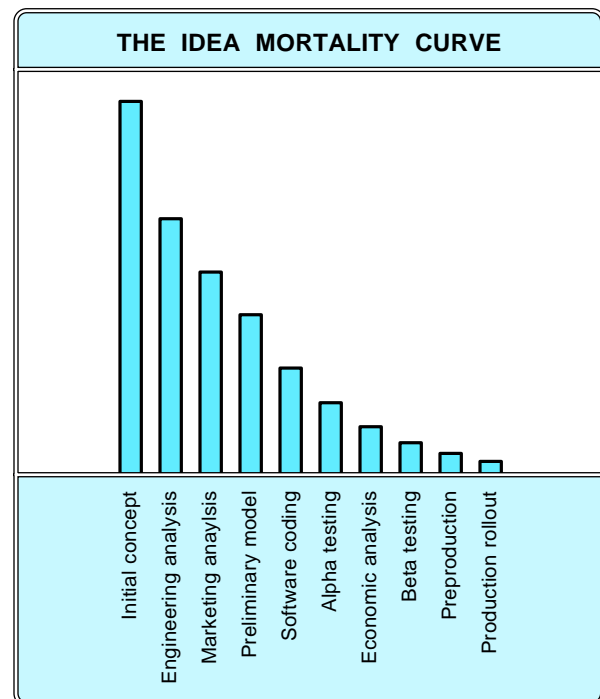

Depending on your product, each hurdle may have a different name or might get used in some different order. Regardless, each successive hurdle causes many of those remaining ideas to fail. The net result is that *nearly all of your ideas will ultimately turn out to be bad ones.*

If you are a manufacturer or a marketing firm, your obvious goal is to *get rid of as many ideas as early as you possibly can.* Ruthlessly stomp them out. The longer any bad idea continues, the more it will cost in development time and dollars. And the more you will lose.

The further to the right along the mortality curve, the lower the risk and the faster the time to market. Thus, it pays any manufacturer or marketer to *buy in as far to the right* as possible along this curve. For this reason, getting paid upfront cash for an unproven raw idea is something that just ain't gonna happen. Ever.

The idea mortality curve is very steep. Just how steep?

My first guess is 500:1. Or thereabouts. Five hundred well thought out and carefully considered initial ideas for every ultimate out-the-door product.

The *Batelle Memorial Institute* is a highly reputable old line invention development firm. They accept around 4000 ideas per year, and end up with 8 useful ones.

One of the more blatantly misbehaving "idea marketing" firms discloses that of 2500 ideas accepted, only 5 were actually licensed to a third party. Of these a mere *one* generated a worthwhile net positive cash flow. Once again, the odds seem to be 500:1.

Note that all gambling casinos offer odds ridiculously better than 500:1, as do most state lotteries.

The 500:1 figure assumes that you are a knowledgeable industry insider. Who aggressively uses the trade journals, professional associations, and online resources. And who thoroughly understands the engineering, mathematical, marketing, distribution, and economic underpinnings for the target field. If you are an outsider, your odds are likely to end up worse than 1,000,000:1 instead.

Simply because the gotchas will git ya. Every time.

Thus, churning ideas into real world products with positive cash flows ends up much worse than a crap shoot. *Anything you can do to successfully move a step or more to the right on the idea mortality curve should significantly reduce the risks involved.*

### Some possibilities

The concept of "not needing a model" for an idea is ludicrously absurd. If you have a product you want to sell, you should have it well beyond your advanced beta test. Where outside third parties are thoroughly evaluating your designs in a genuine end-user environment. As a general rule, *you have absolutely nothing until you successfully get out of beta test.* Zilch.

The key point here: *The more steps on the idea mortality curve that you are able to internalize, the higher your odds of successfully selling your results.*

A typical company would be infinitely more interested in working preproduction models and software, beta test results, and ready-to-go production artwork. Compared to *ever* paying cash up front for raw ideas.

You can decide which portions of the idea mortality curve to internalize, but *the more the better.* Any move to the right dramatically lowers the risk.

### Getting paid

There are a number of obvious payment routes. You can charge a flat fee for a service delivered. Cash and carry. Such as for printed circuit artwork.

You can charge so much an hour for your time. Such as for open-ended research. Or a flat fee plus expenses if materials costs, on-line charges, or travel are involved. Or for books or other high volume products, you can charge a royalty of so much per unit actually sold.

Royalties cost the manufacturer or marketer much less in up front expenses, and can lead to open ended big bucks. The downside to royalties is that you may never see any of them at all. Or too little arriving too late.

Perks and trades can also be useful as *partial* payment methods. Such as keeping gear used for beta testing.

Naturally, all the costs and payment methods must be

clearly spelled out ahead of time. Certainly as written contracts if any big bucks are involved.

As before, you should ask the key question: Which payment system will offer the greatest risk reduction to your client? Consistent with a fair return for you.

My own preference is to usually seek out a flat fee up front, combined with a per-unit royalty. And, if possible, some "keep the equipment" or "vacation travel" perks.

I've often found that *indirect* payments work out better long term than direct ones. These can be book or product royalties, online sysop fees, or simply part of the price of a newsstand magazine. Rather than one firm paying you big bucks, thousands of individuals pay you pennies instead. Largely unwittingly and unknowingly.

Two of my favorite indirect methods are the *advertorial* and the *editorial exchange*. In an advertorial, you get paid for delivering purportedly stand-alone and useful technical information. While leaving a strong urge for the reader to whip out his VISA card. In an editorial exchange, you are given ad credit as partial payment for a technical story. The magazine has less out-of-pocket expense, and the ad can generate additional cash for you.

More on all these concepts on [www.tinaja.com](http://www.tinaja.com) and in my *Blatant Opportunist* reprints.

One trick to guarantee flat fee payment from any new or questionable client: Price your work at *twice* the bare minimum you are willing to receive for it. Then demand a prepayment of *fifty percent*. Cash up front.

### Mining fallout

There's another route to indirect payments that I like to call *fallout*. As a purveyor of risk reduction, there are times and places where you can profit *even when the underlying idea falls off the mortality curve!* You can do this if your work generates new opportunities along the way.

The work on your project might take you into a new learning area. Or generate leads for technical articles, ap notes, resource surveys, BBS uploads, or even books and videos. Or simply get you to thinking about something in depth. Chance favors the prepared mind.

An example: A potential client once sent me a copy of his woefully abysmal patent. One that clearly violated great heaping bunches of fundamental engineering principles. Would I please give him a list of lower cost off-the-shelf suppliers that make the magic material required?

It was clear at a casual glance that his R&D work was mostly wishful nonthinking. Despite this, I spent lots of time and effort finding out just *why* his patent was a total disaster. I actually did a full formal engineering analysis. At no charge, and on spec.

From the detailed study, I was able to come up with and profitably publish a dozen story ideas that hopefully might prevent others from making the same stupid mistakes. One was on fundamental physical principles. Another a research survey on all those magic suppliers and what they can and cannot do. Another on some electrical basics. Another on the utter futility of patenting untested ideas.

There is a fine line here. Your client will get bent if you steal his idea outright and sell it to a competitor. The trick is to harvest any *intangibles* which can be fairly applied elsewhere to your own work and the work of others.

The amount of fallout can influence your pricing. You'll



want to charge more for any risk reduction purveyance that is so unique or so restrictive that your fallout is limited. On the other hand, if whole new worlds open up, you can often charge less for your direct return.

## Two examples

I've often found that smaller projects work out much better than larger ones. Once again because of those risk factors. A project with a total potential return of several hundred dollars is much more likely to turn out well for all concerned than a larger one. And every so often, one of the little jobs will turn into a real biggie.

The unvarnished truth about big job megabucks is that you'll get shellacked every time you go after them.

You do, of course, have to be quite time efficient with smaller jobs. But once you are into the process and rhythm of continuously and reliably producing smaller tasks, they can become more profitable. Especially with fallout. And the small jobs give you higher odds of getting paid.

Let us look into two examples of smaller risk reduction purveyance jobs that worked out well for me...

Dennis Carper runs *Redmond Cable*, a hacker-friendly outfit that makes up custom and stock cables to literally connect anything to anything. Dennis had observed a little known connector on those *Super Nintendo* game machines that could be used to drive video monitors and obtain full stereo sound. Which might give you much higher quality sound and images. Or else unload the kiddiekrons off a prime time tv and onto a junk monitor.

The problem was that the machine couldn't drive a Commodore monitor without tearing badly. So Dennis sent me a Super Ninny, a monitor, and bunches of cable bits and pieces. Would I analyze the signals and come up with a universal "anything-to-anything" game interface?

The Commodore problem was easy. Routine scope work. Commodore, being Commodore, needed upside down sync, and a plain old CMOS inverter gave us a quick cure here. After further study, I designed a two-chip module which could solve most any video game interface.

Payment in this case was a fairly small fee up front that covered my bare bones time and parts costs, an ongoing five percent royalty on all units sold, and getting to keep some of the games as a perk. To this day, the small royalty checks continue to reliably come in.

Fallout did include several [Hardware Hacker](#) stories in [Electronics Now](#) that generated additional cash, created new cable sales, and led to other consulting work.

John Rees is a hardware hacker from the deep south who is into all sorts of unique stuff from weaving looms to lost wax investment casting. One of John's bigger projects is a humongous CAD/CAM sign router he built himself out of local found materials. The key secret to John's machine is using car alternators as power steppers. This offers lots of cost savings over traditional large steppers.

John produced an hour long and rather "down homey" video that demonstrates his router in action, shows you how to build up your own version, and steps you through the details of alternator rewinding, drive hardware, and support software. It was extremely well done.

My involvement was first to convince John he had a winning product. And then to make others aware of his video. This was done for a flat royalty fee of five percent

## RISK REDUCTION RESOURCES

### Batelle Pacific Northwest

Box 999, K6-54-Watts  
Richland, WA 99352  
(509) 372-4274

### CompuServe

5000 Arlington Center Blvd  
Columbus, OH 43220  
(800) 848-8199

### Dialog Info Services

3460 Hillview Avenue  
Palo Alto, CA 94304  
(415) 858-2700

### Electronics Now

500-B Bi-County Blvd  
Farmingdale, NY 11735  
(516) 293-3000

### Genie PSRT

401 N. Washington St.  
Rockville, MD 20850  
(800) 638-9636

### Redmond Cable

17371-A1 NE 67th Ct.  
Redmond, WA 98052  
(206) 882-2009

### John Rees

Rt 1, Box 1551  
Sautee, GA 30571  
(706) 865-5495

### Synergetics

Box 809  
Thatcher, AZ 85552  
(602) 428-4073

of the selling price. I did this through my usual mix of tech stories, advertorials, and my online postings. Because I was thoroughly impressed with the quality of John's video and because alternators-as-steppers is a favorite ongoing theme of mine, I could heartily recommend the vid.

John's risk reduction here seems obvious. Instead of his gambling on when and whether a video could be sold and putting up lots of front-end advertising and promotion costs, a fixed flat fee gets paid when and as the videos are sold. John now knows precisely what his promo expenses are and doesn't have to pay them until the videos are actually delivered. And now has a national market.

## For more info

I've gathered a few references together into our *Names and Numbers* sidebar. Check here for additional info on custom cable services or alternators-as-stepper videos.

To research any technical subject at any time and any place, I cannot recommend the *Dialog Information Service* too highly. Dialog has recently offered new and convenient cash-and-carry services by way of both *CompuServe* and *Genie*. For as little as thirty cents per title.

A pair of freebie new resources is available from *Batelle Pacific Northwest*. One is the *Inventor Assistance Source Directory*, while the second is their *Prototype Development Assistance Providers*. But don't expect any resource on the second list to buy raw ideas. Noway, nohow.

Much more info on successful idea development and marketing appears in my [Incredible Secret Money Machine](#) and [The Case Against Patents](#) package. Or you can use my free helpline as noted below. ♦

*Microcomputer pioneer and guru Don Lancaster is the author of 33 books and countless articles. Don maintains a US technical helpline you'll find at (520) 428-4073, besides offering all his own books, reprints and various services.*

*Don has a free new catalog crammed full of his latest insider secrets waiting for you. Your best calling times are 8-5 weekdays, Mountain Standard Time.*

*Don is also the webmaster of [www.tinaja.com](http://www.tinaja.com) where a special area has been set aside for Midnight Engineering readers. You can also reach Don at Synergetics, Box 809, Thatcher, AZ 85552. Or email [don@tinaja.com](mailto:don@tinaja.com)*



# Busting a \$650 Patent

I recently received some email from a proud individual who had just gotten his very own \$650 patent. All by himself. His reasoning was that all he needed to pay for this patent was a trifling \$1300 in sales.

He was assuming a 50% net profit margin.

Well, first off, his analysis overlooked the crucial point that *your costs of getting a patent end up utterly negligible compared to your costs of defending a patent*. A patent is simply a piece of paper that purportedly gives you the right to sue someone in a court of law.

Yes, typical court costs of two challenges and an appeal can sometimes be held down to \$240,000.00. But they are usually *much* higher. These days, even the patent litigation insurance premiums start off at \$65,000.00.

The sad fact of the matter is this: The odds tell us *there is no conceivable amount of net sales which could ever even remotely hope to begin to pay for a \$650 patent*.

The reason? *There is not one patent in a thousand that cannot be busted by a diligent enough search for prior art done in obscure enough places*. But most \$650 patents are notoriously easier to bust. Trivial even. Making the odds of success all that much more dismal.

The bottom line: *You will be permitted to keep your \$650 patent only until such time as you try to enforce it*.

A \$650 patent is almost certainly a ludicrously "weak" patent. One that does not have a snowball's chance in hell of withstanding any even remotely serious challenge.

I very strongly feel those "patent it yourself" books are a big disservice to most individuals and small scale startups. Because they encourage wasting your time and money only to get a totally useless result.

Should you send someone a "you are violating my \$650 patent" nastygram, your immediately *guaranteed* result is that you will instantly convert what should have been your best customer into a big time enemy who will now dedicate their life to doing you in.

Your new lifelong enemy will then decide to (a) ignore your letter, (b) bust your patent outright, or (c) improve their product while rendering your patent moot.

That unthinkably bizarre urban lore fantasy of "paying royalties" never even enters their mind.

Not for an instant.

There is, however, one anecdotal use for \$650 patents. If you frame one of these and place it on your wall, they do seem to prevent walrus attacks.

Let's take a look at a few of the main approaches that are routinely used to bust a weak patent...

**Show prior art**—To be patentable, a concept has to be *new*. So many people seem to have so much trouble over such a simple word. Well, "new" means that nobody, *but nobody*, has ever thought of this idea before. There must be *nothing* written about anything similar *anywhere* in the world. In any form. However obscure.

Anytime, ever.

At least 95% of your quest for prior art should take place *outside* of the patent system! In the industry trade journals, product catalogs, shows, newsletters, seminars, and stores. Since less than one well researched and well funded patent in two hundred ever creates a net positive cash flow, we have this set of rules...

*winners appear in the marketplace  
losers appear in a patent repository*

Because so many people are thinking about so many things in so many ways, *synchronicity* virtually guarantees that your concept is not new. In fact, your "new" concept probably has been thought about and trashed over decades ago. One possible exception is when you are truly and genuinely beyond the bleeding edge of technology in any rapidly emerging field. And have committed yourself on a total lifestyle basis.

**Show the failure to disclose**—Any and all previous patents even remotely related to your claims absolutely must be clearly identified in your application.

Failure to disclose trashes your patent.

Until recently, competent and thorough patent searches were a real bear to do. But thanks to that free IBM patent repository up at [patent.womplex.ibm.com](http://patent.womplex.ibm.com), you can instantly search everything back to 1971. Full text, figures, and even forward referrals.

I selected two patents nearly at random from this great service. And ended up two for two in fine candidates for my patent horror story collection.

In one case, a "new" patent was fully described in a 1937 issue of *Radio News*. And was a mainstay of the electronics books of the 1940's. They also did not pick up on the fact that their old circuit was now *illegal* because of how badly it trashed the ac power line.

In the other case, I had personally published their exact circuit waveforms fifteen years earlier in a major technical publication. At the time, my specific intent was to put this concept in the public domain.

Where it remains to this day.

**Show obviousness to a practitioner**—Simply being new will not hack it. Your idea also has to be *non-obvious* to any practitioner in the field. If what you are up to does not appear as a really big deal to an insider, then it flat out is not patentable.

I recently got a call from somebody who was trying to patent a display device that used ordinary lamps, plain old optic fibers and a rechargeable battery. Seemed completely obvious to me. And also to *American Science & Surplus* or *Edmund Scientific*. Who have both sold catalog variations on these for many years.

Yes, the roles of expert witnesses are being called more and more into question these days. Amazingly, the term "obvious" can permit lots of different interpretations for different people. But the fact remains that *if it is obvious, it cannot be patented*.

Obviousness is an especially dangerous trap for industry outsiders. If you are not the sort of person who aggressively subscribes to those relevant trade journals and thoroughly understands how products are created, advertised, and sold in your target industry, then your odds are overwhelming that you are working on an unpatentable non-solution to a non-problem. Nearly every time.

Like all of those "miracle carburetor" enthusiasts on the web. Who have not yet picked up on the news that nobody uses carburetors any more.

**Show technical errors**—An amazing number of patents flat out *do not work*. Which is probably one of the reasons that their working models never made it through beta test.

In one recent sad example, a patentee noticed that if you take two light dimmers and put a 110 volt bulb on one and a 32 volt bulb on the other, a cheap voltmeter might show three times the current and three times the voltage on the 110 volt bulb. For *equal* brightness. They then apparently concluded that three times voltage and three times current "had" to be nine times power, and claimed a 90% efficiency improvement. For a home lighting revolution.

Uh, they obviously did not bother touching their 32 volt bulb, since it would have to be quite *cold to the touch* to justify such an efficiency claim. Uh, there'd also be a few minor problems with black body radiator physics.

In their patent claims, they clearly and obviously stated a maximum possible "cheap voltmeter" error of 10%. When in fact, their actual rms-to-average error was 300% and completely accounted for the erroneous effect they thought they were seeing.

Which, by the way, is a gotcha that every circuit theory book warns you against. In bold print. A complete analysis of this fascinating fiasco can be found in [MUSE112.PDF](#) and [MUSE113.PDF](#) on my [www.tinaja.com](http://www.tinaja.com)

Other areas where technical error comes into play is any time the first or second law of thermodynamics appears to be violated. All perpetual motion machines are specifically unpatentable. But various proponents of "overunity" or "zero point energy" devices try to weasel word themselves around this restriction.

More pseudoscience in [www.tinaja.com/pseudo01.html](http://www.tinaja.com/pseudo01.html)

Showing technical error is often better at disallowing specific patent claims, rather than busting an entire patent. But a weak patent made weaker can sometimes be all that's needed to disallow an infringement.

**Show procedural errors**—There are all kinds of arcane rules and restrictions that are involved with creating patent drawings and the actual submission process. Fail to dot the tee and cross the eye in the exact manner specified, and you are open to challenge.

Common sense, of course, has nothing whatsoever to do with the rules and regulations. Inexperienced patentees are pretty near certain to make submission blunders.

**Show failure of due diligence**—I'm not sure I follow this potent busting tool fully, so do check this out with your patent attorney. But as I understand it, slashing away at a sudden target of opportunity is a no no.

It seems *you* have to *aggressively* police the industry for violators. You also have to show *continuous* intent to *both* license and enforce.

Apparently if there has been significant and widespread infringement of your patent in the past, and if you have done nothing about it, you cannot suddenly single out any one particular perp. Especially if they have been blatantly (love that word) doing so for a long time.

Use it or lose it.

Sorta like the rule that you can't *suddenly* foreclose on somebody's house when they've had a long history of late payments. Your acceptance of late payments in the past implies that you will accept them in the future.

Sounds kinda like catch 22 to me. Lawyers should really love this one.

More details in on due diligence appear in the May 1997 *Journal of Proprietary Rights*, page 15.

**Start a paper blizzard**—If all else fails, there is one ploy a patient and well-heeled patent challenger can always try. I'll call this the *paper blizzard*. In which they make your life so miserable for so long that you simply give up.

You start a paper blizzard by asking for dispositions of records the patentee either does not have or does not wish to part with. Doing so, of course, at times and places that are as inconvenient, as embarrassing, as intimidating, as obnoxious, and as invasive as possible.

Using that old Parkinsonian law of *delay is the surest form of denial*.

Yeah, a paper blizzard is harrassment. Plain and simple. But hey—it works. And I know of only one proven defense against the paper blizzard. And that is to *never, ever* seek a patent in the first place. The "hit it fast and hard, then get out" patent alternative makes a lot more sense to me.

## For More Help

Naturally, these guidelines can be used to bust nearly any patent. Not just the sloppy bargain basement ones. The important point to note is that *iffen the right one don't git ya, then the left one will*.

Your first and best place to look for prior art is in the trade journals. While *Ulrich's Periodicals Dictionary* has long been the definitive source for this sort of thing, the fine *Oxbridge Media Finder* at [www.mediafinder.com](http://www.mediafinder.com) is now a lot faster and cheaper.

One great source for really ancient prior art is *Lindsay Publications* They've got all sorts of ancient historical books on mechanical and trade secrets. You can visit them at their [www.keynet.net/~lindsay](http://www.keynet.net/~lindsay) website.

These days, it is super important to aggressively use the



## MENTIONED RESOURCES

### Amazon Books

Box 80387  
Seattle WA 98108  
(800) 201-7575

### American Sci & Surp

3605 Howard St  
Skokie IL 60076  
(708) 982-0870

### Edmund Scientific

101 E Gloucester Pike  
Barrington NJ 08007  
(609) 573-6250

### Jnl of Proprietary Rights

1185 Americas Avenue  
New York NY 10036  
(800) 901-9075

### Lindsay Publications

PO Box 538  
Bradley IL 60915  
(815) 935-5353

### Oxbridge

150 5th Ave #202  
New York NY 10011  
(212) 741-0231

### Synergetics

Box 809  
Thatcher AZ 85552  
(520) 428-4073

### Ulrich's Dictionary

121 Chanlon Rd  
New Providence NJ 07974  
(908) 771-7714

## RECOMMENDED WEB SITES

[www.amazon.com](http://www.amazon.com)

[www.keynet.net/~lindsay](http://www.keynet.net/~lindsay)

[www.patent.womplex.ibm.com](http://www.patent.womplex.ibm.com)

[www.tinaja.com/patnt01.html](http://www.tinaja.com/patnt01.html)

[www.mediafinder.com](http://www.mediafinder.com)

Internet. To the point where I'll claim that *it is categorically impossible to successfully develop a product without very aggressive use of all available web resources.*

Online research tutorials now appear on the Webmaster Library Shelf of [www.tinaja.com/weblib01.html](http://www.tinaja.com/weblib01.html)

Two effective web search tools are [www.hotbot.com](http://www.hotbot.com) and [digital.altavista.com](http://digital.altavista.com) A great free "search all sites" site is at [www.wp.com/resch/search.html](http://www.wp.com/resch/search.html)

Yes, there still *may* be times and places where a patent *might* be appropriate. So long as you studiously ignore the urban lore and all the scams and ripoffs that are inevitable any time the word "inventor" gets mentioned or appears in print. And so long as you realize that your breakeven costs of *any* patent are *ridiculously* higher than you might first assume. Usual breakeven is \$12,000,000.00 in sales.

And that patents are *strictly for insiders only*. And often are a time and sanity wasting sideshow which has *nothing whatsoever* to do with successful product development and marketing. Especially in fast changing fields.

Much more on this in [WHEN2PAT.PDF](#) and related files on the Patent Avoidance Shelf of <http://www.tinaja.com>. I've also got a Case Against Patents package plus my brand new [Infopack](#) research service. More on small scale tech ventures in general is in my [Incredible Secret Money Machine II](#) book.

Details per my nearby [Synergetics](#) ad. ♦

---

*Microcomputer pioneer and guru Don Lancaster is the author of 33 books and countless articles. Don maintains a US technical helpline you'll find at (520) 428-4073, besides offering all his own books, reprints and various services.*

*Don has a free new catalog crammed full of his latest insider secrets waiting for you. Your best calling times are 8-5 weekdays, Mountain Standard Time.*

*Don is also the webmaster of [www.tinaja.com](http://www.tinaja.com) where a special area has been set aside for Midnight Engineering readers. You can also reach Don at Synergetics, Box 809, Thatcher, AZ 85552. Or email [don@tinaja.com](mailto:don@tinaja.com)*



by Don Lancaster

# Inventor's Associations

The term *mark* comes from the carnival midway. Any time a scam operator (the *rube* in carneyspeak) had significantly lightened a prospect's wallet, he would give him a friendly exiting pat on the back. Along with an encouraging "Gee Fella, that's too bad."

Unmentioned and unbeknownst to the lightenee was the fact that the rube had secretly dipped his hand in a hidden stash of powdered chalk before the pat on their back. Thus *marking* a large "X" on the lightenee and identifying him as worthy of special treatment by the next rube in line.

Eventually, every non-rube who so much as entered the carnival midway area became known as a mark. And were contemptuously treated as such.

These days, we do not have too many marks left. So, you just substitute the term *inventor* instead. Any time an "inventor" context crops up, you are assured of an uneven playing field very much comparable to a carnival midway or a casino floor. A scene which is intended primarily to (A) liberate as much money as possible from the mark, and (B) to keep the status quo exactly where it is.

The foremost reason to studiously avoid any "inventor" context is the totally absurd popular mythology that now surrounds patents and inventing. Nearly all of which is dead wrong. To prove this to yourself, just mention the word "patent" at any party and then observe the ludicrous disinformation heaped upon you. Then challenge them to name *one* single individual anywhere, ever, *whom they personally know* that, *in a small scale context*, has shown a net positive cash flow from their patent involvement. A cash flow that was worth the time and effort.

No, the windshield wiper guy hasn't collected yet. The Sears wrench dude wasted his entire lifetime by tilting at windmills. To me, Hyatt looks like a rube. Tesla died a pauper. The patent system drove Armstrong to suicide. And Edison was a ripoff artist who made most of his bag by simple theft, using the most ruthless gaggle of renegade patent attorneys ever assembled anywhere.

So much for urban lore.

Out of some *six million* patents filed to date, I have yet to find *one* example of a lone individual who has profited from patents. On the other hand, my patent victim files are bursting at the seams. Putting my money where my mouth is, a free new *Incredible Secret Money Machine II* to any current *Midnight Engineering* subscriber who is able to personally claim a worthwhile positive net cash flow from their patent involvement done as an individual or small scale startup.

As a mark and not a rube, of course.

The second largest reason for the uneven playing field is the patent system itself. As we have seen back in *Midnight Engineering #6* and in the *Blatant Opportunist* reprints: *Any individual, Midnight Engineer, or other small scale involvement in the patent system is virtually certain to end up as a net loss of time, energy, money, and sanity.* Most often, your state lottery is a vastly better investment.

Very simply, patents are almost always inappropriate, counterproductive, time-wasting, vibe-destroying, and totally unnecessary tools. When used within most *Midnight Engineering* contexts.

As we have seen before, it is fine to act as an *industrial product developer*, run a *prototyping house*, be a *concept consultant*, or work as an *evaluation specialist*. All of these form acceptable roles in society for which, at least occasionally, you might end up being quite well rewarded. These are also the sorts of things which you, as a *Midnight*

*Engineer* should be striving towards.

Now, I simply cannot fathom why anyone would ever purposely refer to themselves as an "inventor". This is the equivalent of pre-chalking yourself before you enter the carney midway. Which leads us to Horschnoggle's first and second rules...

**RULE #1– Do not ever, under any circumstances, call yourself an inventor or behave like one.** To do so will open you up to interminable scams. Don't even let anyone else so much as suspect that you are capable of inventing or successfully marketing anything.

**RULE #2– If you ever associate yourself with any inventor's resource, use a fake name and wear a disguise.** Remember that you are an impartial observer and a disinterested outsider. You are neither a mark nor a rube. You are a *Midnight Engineer* seeking new contacts, resources, and networking.

## The "Meadow Four" Metaphor

It seems that there are an incredible number of obscure inventor's associations and organizations out there. It took quite a bit of digging, but many of them appear in our nearby *Inventor's Associations* sidebars. As a *Midnight Engineer*, you probably will be interested in these for potential markets and as local networking contacts.

Just remember that *any* group has goals that are often different from, and possibly in direct conflict with, those of

**These days, we do not have too many marks left. So, you just substitute the term "inventor" instead.**

## INVENTOR'S ASSOCIATIONS (AL-IN)

Leonard W. Owen, Alabama Inventors Group, 1000 St. Moritz Drive West, Mobil, AL 36608	(205) 633-9431
Janet M. Nye, Small Bus. Develop. Center, 430 W. 7th Ave, Suite 115, Anchorage, AK 99501	(907) 272-4333
John Pursley, Alaskan Inventors Office, P.O. Box 241274, Anchorage, AK 99524	(907) 563-1274
John W. Siber, Alaska Sci & Tech Foundation, 550 W. 7th Ave, S360, Anchorage, AK 99501	(907) 272-4333
Robin Zerbil, President, Alaska Inventor Association, P.O. Box 241801, Anchorage, AK 99524	(907) 273-5473
Jay D. James, President, Inventors Institute of Alaska, P.O. Box 181327, Wasilla, AK 99687	(907) 376-4604
Marland Bull, AR Inventors Congress, Inc., Route 3, Box 670, Dandanelle, AR 72334	(501) 229-4515
Sam Pruett, Genesis Incubator, Eng Res Ctr, U of AR, Fayetteville, AR 72701	(501) 575-7227
Dr. Gary Argue, AZ State Research Liason, Arizona State University, Tempe, AZ 85287	(602) 965-9011
Paul A. Baltess, Professional Education, U of AZ, Box 9, Harvill Building, Tucson, AZ 85721	(602) 621-2211
Terry Chappell, Santa Cruz IWIEF Chapter, 730 Encino Drive, Aptos, CA 95003	(408) 662-1936
Mel Afareo, Asian Inventors & Entrepreneur Co-op, 876 Zeler Avenue, Arleta, CA 91331	(818) 892-9731
Alan Tratner, Inventors Wrkshp Int'l, 3201 Conte Malspaso, S 304, Camarillo, CA 93010	(805) 484-9786
Larry Udell, US Innovative Products Corp, PO Box 2732, Castro Valley, CA 94546	(415) 538-5200
Gene Scott, Orange County IWIEF Chapter, 21975 Trailway Lane, El Toro, CA 92630	(714) 427-1269
Ted DeBoer, Nat'l Inventors Fnd, 345 W. Cypress Street, Glendale, CA 91204	
Arthur Ryan, Inventors Assistance League, Inc., 345 W. Cypress Street, Glendale, CA 91204	(818) 246-6540
Marvin Winner, Gold Coast IWIEF Chapter, 468 Cole Place, Goleta, CA 93117	(805) 967-3176
William Otterson, CONNECT Technology, UCSD, X-001, La Jolla, CA 92093	(619) 534-6114
Violet Winstone, Ontario IWIEF Chapter, 1845 Bonita Avenue, La Verne, CA 91750	(714) 593-1101
Dave Merchant, Ent Inst, Cal State LA, 5151 State University Dr, Los Angeles, CA 90032	(213) 469-9767
Ken Rosenthal, Patent Admin, USC, 3716 S. Hope Street, S 200, LA, CA 90007	(213) 740-2311
Robert Stark, Inv Wrkshp, NASA Ind App, USC R200, 3716 S. Hope Street, LA, CA 90007	(213) 743-6132
Norm Parrish, NCIO, 215 Rheem Blvd., Moraga, CA 94556	(415) 376-7541
Jay Snell, IWI, 118 Brenton Ct., Mountain View, CA 94043	(415) 969-7974
Michael R. Hamlin, 666 Heather Street, Ojai CA 93023	(805) 649-2815
Bob Smith, A Flash of Genius, PO Box 731, Pacific Palisades, CA 90272	
Paul Dieges, Perris IWIEF Chapter, 1051 Davids Road, Perris, CA 92571	(714) 657-2822
Wally Jones, Redlands IWIEF Chapter, 1004 Cajon, Redlands, CA 92373	(714) 798-1451
Mike Cifra, Riverside IWIEF Chapter, 4041 Pedley Road, Riverside, CA 92509	(714) 684-5729
Bud Miller, Sacramento IWIEF Chapter, 3307 Barcon Way, Sacramento, CA 95838	(916) 927-9463
Richard Ditzik, San Diego IWIEF Chapter, 3143 Carnegie Ct., San Diego, CA 92122	(619) 546-8535
Barret Johnson, California Inventor's Council, P.O. Box 2036, Sunnyvale, CA 94087	(408) 376-4314
Russ Beach, South Bay IWIEF Chapter, 2113 West 177th Street, Torrance, CA 90504	(213) 217-8988
Robert Sperry, Ventura IWIEF, 23390 Ostronic Drive, Woodland Hills, CA 91367	(818) 340-4629
Rocky Mountain Inventors and Entrepreneurs, 3405 Penrose Place #104, Boulder, CO 80301	(303) 989-8301
Rocky Mountain Inventors Congress, 2525 Arapahoe Avenue, S E4-252, Boulder, CO 80302	(303) 443-6200
Cornelia Snyder, Rocky Mountain Inventors Congress, PO Box 4365, Boulder, CO 80204	(303) 758-6757
John T. Farady, Affiliated Inventors, 2132 East Bijou Street, Colorado Springs, CO 80909	(719) 635-1234
Morton Leyand, National Inventors Association, PO Box 6585, Denver, CO 80206	(303) 797-7540
Bill Van Arsdale, Rocky Mountain Inventors, 2753 S. Webster Street, Denver, CO 80227	(303) 989-8301
Stephan Andrade, Gov High Tech Cncl, 3271 South Clay, Englewood, CO 80110	(303) 781-4039
Dr. Patrick MacCarthy, Colorado School of Mines -SPACE, Golden, CO 80401	(303) 273-3321
Mike McKenzie, Colorado Inventors Council, PO Box 88, Holyoke, CO 80734	(303) 854-3851
B. Friendlander, Venture Mgmt Ctr, U. Bridgeport, 141 Linden Avenue, Bridgeport, CT 06601	(203) 576-4572
The Inventors Ally, 1095 Middlebury Road, Middlebury, CT 06762	
David Drive, Connecticut Innovations, Inc., 845 Brook Street, Rocky Hill, CT 06067	(203) 258-4305
Bruce Mims, Inventors Association of CT, Greenfarms Box 153, Westport, CT 06436	(203) 259-1174
Murray Schiffman, Inventors Association of CT, 9 Sylvan Road South, Westport, CT 06880	(203) 226-9621
Ray Barnes, Enr Inv, CE-521 5E-052, DOE, 1000 Independence SW, Wash. DC 20585	(703) 557-3158
Harry Manbeck, Patent Office, Commerce Dept, Washington, DC 20231	
Herbert Wamsley, Intel Prop Ownrs, 1255 23rd Street NW, S 850, Wash. DC 20037	(202) 466-2396
Pamela Riddle, FL Product Innovation Center, 1 Progress Blvd., Alachua, FL 32615	(904) 462-3942
Herbert Stillman, Inventors Society of So. FL, PO Box 4306, Boynton Beach, FL 33424	(407) 482-6343
Robert E. White, Amer. Inventors, Box 4306, Boynton Beach, FL 33424	(407) 736-6594
Linda R Mazeika, Orlando IWIEF Chapter, 1131 Adams Street, Hollywood, FL 33013	(315) 920-9173
Steve Chandler, Sunrise Inventors Associations, 6402 Gamble Drive, Orlando, FL 32818	
David Flinchbaugh, Central FL Inventors Council, 4855 Big Oaks Lane, Orlando, FL 32806	(407) 859-4855
William R. Bowman, Inventors Club, WSRE-TV, 1000 College Blvd., Pensacola, FL 32504	(904) 478-5800
Ray Purdy, Tampa Bay Inventors, 13543 Perrywinkle Avenue, Seminole, FL 34646	(813) 391-0315
Maury Hagerman, Entr Prog., BA/DC, 107 W. Gaines St, Room G-26, Tallahassee, FL 32399	(904) 487-0463
Don M. Koenig, Inventors Clubs of America, 3166 Maple Drive, Suite 219, Atlanta, GA 30309	(404) 938-5089
George Mitchell, IA of Georgia, 675 W. Peachtree St, Rm 31T 69, Atlanta, GA 30375	(404) 420-2468
Hal Stribling, Inventors Assoc. of Georgia, 241 Freyer Drive NE, Marietta, GA 30060	(404) 427-8024
George K. C. Lee, President, Inventors Council of Hawaii, Box 27844, Honolulu, HI 96827	(808) 595-4296
Ken Boyce, Chicago High Tech Assn, 53 W. Jackson Blvd, Suite 1634, Chicago, IL 60604	(312) 939-5355
Barb Campbell, Tech Comm Ctr, 100 West Randolph St, S 3-400, Chicago, IL 60601	(312) 917-3900
Stephen Fraenkel, Tech Comm, IIT, 10 W. 31st St, R 229B-Stuart, Chicago, IL 60616	(312) 567-5115
Don Moyer, Inventors Council, 53 W. Jackson, #1041, Chicago, IL 60604	(312) 939-3329
G. Van Wagenen, Tech Comm, U. of IL, 815 West Van Buren, Chicago, IL 60607	(312) 996-9132
Peter Whalley, Sociology Dept, Loyola U, 6525 N. Sheridan Road, Chicago, IL 60626	(312) 508-3453
Larry Sill, Tech Comm Center, Northern Illinois University, DeKalb, IL 60115	(815) 753-1238
Dave Rupert, Central Illinois Inventors, TCC Illinois State University, Normal, IL 61761	(309) 438-2111
Daniel Voorhis, Tech Comm Ctr, Illinois State U, Hovey Hall, Normal, IL 61761	(309) 298-2211
Mike Kalb, W. Illinois Inventors Council, 121 Pine Street, Oneida, IL 61467	(309) 483-6332
Nicholas Parnello, Am. Inventors Council, PO Box 4304, Rockford, IL 61110	(815) 968-1040
Jack L. Banther, Prof Inventors Intl, Rte 10, 4412 Greenhill Way, Anderson, IN 46011	(314) 649-7288
Prof. Daniel Yovich, Inventors & Entrep. Soc. of IN, PO Box 2224, Hammond, IN 46323	(219) 989-2354
Randall N. Redelman, President, Indiana Inventors, PO Box 2388, Indianapolis, IN 46206	(317) 745-5597
Tom Nix, Prof Inventors Intl, 818 Westminster, Kokomo, IN 46901	(317) 459-3553

its members. Surprisingly, very few of these groups have heard of either Bill's *Midnight Engineering*, or *The Incredible Secret Money Machine II*. Sigh.

The groups strongly remind me of a pasture or a meadow. These tend to arrange themselves as *wolves*, *sheep*, *shepherds*, and *watchdogs*. Let's look at each resource group in turn...

### The Wolves

Everybody picks on poor old lobo. Yet *canis lupis* gotta eat. And they do cull the herd of the weak, the infirm, or, in this case, the abysmally naive and the monumentally dumb.

The wolves, of course, are all those invention marketing firms. You can get a complete list of these by cutting out all the fine print classified ads in *Popular Science*, *Popular Mechanics*, *Entrepreneur*, and similar places that scream "Inventions Wanted".

Just as typical vanity publishing offprints form the kiss of death for a first novel, many invention marketing firms are the kiss of death for any developable product. These outfits are basically hired guns, who, for a price up front, do perform various services. Such as patent searches, data bases, press releases, or invention fairs. You already know what an invention fair is – That's a place where you go to steal the few good ideas and laugh at all the rest of them.

You normally would not ask an ad agency if you needed an ad. Nor a used car dealer if you needed a car. Nor a mugger if you needed mugged. So what answer would you expect if you asked an invention marketing firm if your new idea was worthy of development? Give me a break.

The wolves are largely responsible for all of the absurd popular patent mythology. That quarter you sent in for your *inventor's idea kit* from a classified *Popular Mechanics* ad in the seventh grade has done far more damage to far more people than you could possibly imagine. The whole "Get an idea" - "Patent It" - "Beat the cash-waving Fortune 500 companies away with a stick" - "Retire rich and famous" outright ludicrousities can all clearly be traced to these insidious, vile, and despicable classifieds.

One of the largest and oldest of these invention marketing firms has recently decided (possibly with the

slightest of federal nudges) to include their track record with their original mailings. The odds of them licensing an accepted and prepaid idea has been 100:1 against, and the odds for any positive cash flow comes in at 700:1 against. Of the few which did show positive results, most of them flat out were not worth the effort.

Now, some people may be appalled at these figures, but they sound about right to me. Successfully turning any raw concept into a positive cash flow is one *very* rough row to hoe. These odds may in fact be much *better* than you can do on your own.

In many ways, the wolves are just selling wish fulfillment and dreams. Again similar to a vanity publisher or, for that matter, an X-rated vid rental. If anything, I pretty much admire the wolves rather than condemning them. After all, a well executed scam is a joy to behold.

And an art form unto itself.

Typical inventors who actually use these invention marketing firms have already preshot themselves in the foot before they've begun and literally do not have a snowball's chance in hell of accomplishing anything.

Almost always, your "new" and "unique" idea is not. Chances are that others have plowed this ground long ago. If not, "synchronicity" just about guarantees that loats of others are now thinking along the same lines.

Over the years, I have developed many ideas and concepts. Several of which I have or continue to receive royalties over. And continue to center my lifestyle on. Countless others of which have failed miserably. On the basis of my own track record and on those of some winning associates, I strongly feel that the following are *absolutely essential* if you are going to profit from a concept or idea:

(A) You must now be a reasonably experienced industry insider, who is eventually capable of turning into a guru or expert.

(B) You have to very aggressively subscribe to all of the more popular industry trade journals.

(C) You must know and love the mainstream industry tools and their supporting math, along with all of the theoretical underpinnings.

(D) You must tune in to the related

## INVENTOR'S ASSOCIATIONS (IA-NY)

Jan DeYoung, IA Small Bus Devel, Iowa State U, 137 Lynn Street, Ames, IA 50010	(515) 292-6351
Nancy Marlin, Provost, U of Northern Iowa, Cedar Falls, IA 50514	(319) 273-2517
Norman Frye, ICubed, Seven Cities Sod, 12554 210 Street, Davenport, IA 52804	(319) 386-4057
Joe Gende, Triple I, 1607 12th Street, Davenport, IA 52804	
Thomas Honsa, Inv Ent Ctr, Marycrest Col, 1007 W 12 St, S312, Davenport, IA 52804	(319) 326-9152
Benjamin Swart, Inventure, Drake U sbdc, 2507 University Ave, Des Moines, IA 50311	(515) 271-2655
Clayton Williamson, Kansas Inventor Assn of Inventors, 2015 Lakin, Great Bend, KS 67530	(316) 792-1375
Debby Kimbrough, KY Bus & Tech, Dev Cab, Capital Plaza Tower, Frankfurt, KY 40601	(502) 564-7670
Vance Smith, Bluegrass Inventors, Box 22031, Louisville, KY 40252	(502) 423-9850
Mary L. Trammell, Technology Transfer, NOU Lakefront Campus, New Orleans, LA 70148	(514) 286-7154
Barbara Wyatt, Worchester Inventors, 132 Sterling Street, W. Boylston, MA 01583	(617) 835-6435
Norman Biggart, New England Inventors, 4 Baron Park Lane, #1, Burlington, MA 01803	(617) 272-1537
Dr. Donald Job, Innovative Products Ctr, PO Box 335, Lexington, MA 02173	(617) 862-5008
Samuel N. Apotstola, Innovation Invention, 132 Breakneck Road, Southbridge, MA 01550	(508) 764-8491
Ann Eskesen, Innovation Dev, 45 Beach Bluff, Suite 300, Swampscott, MA 01907	(617) 595-2920
Andrew Stidsen, Innovation Invention Network, 13 Benjamin Road, Worcester, MA 02173	(508) 799-4951
Richard C. Levy, PO Box 34828, Bethesda, MD 20817	(301) 469-6481
Fred Hart, Invention Evaluation, NIST, Gaithersburg, MD 20899	FTS 879-5120
George Lewett, Invention Evaluation, NIST, Gaithersburg, MD 20899	
Ron Browning-Nash, Am Inventor's Assc, 6006 Greenbelt Rd #345, Greenbelt, MD 20770	
Marcia Rorke, Mohawk Research, 915 Willow Leaf Way, Rockville, MD 20854	(301) 762-3171
Gary Horwath, DC Inventors Chapter, 9900 Georgia Avenue, #702, Silver Spring, MD 20902	(301) 585-5891
Ray Noddins, Innovation Ctr, U of ME Tech Center, 16 Godfrey Drive, Orono, ME 04473	(207) 581-1465
J. Downs Herold, Industrial Dev, U of MI, 2200 Bonisteel Blvd., Ann Arbor, MI 48109	(313) 764-5260
Ed Zimmer, Zimmer Foundation, 1683 Plymouth Road, Ann Arbor, MI 48103	(313) 663-8000
Thomas Schumann, MI Inventors Ctr, Ferris State U, 1020 E. Maple, Big Rapids, MI 49307	(616) 796-3100
Dennis Martin, Am. Inventors Assc, 6562 E. Curtis Road, Bridgeport, MI 48722	(517) 799-8208
Barb Eldersveld, MI Inventors Council, Tech ctr, 2727 Second Avenue, Detroit, MI 48201	(313) 963-0616
Joe Nies, Industrial Dev Bureau, 311 Houghton Street, Ontonagon, MI 49953	(906) 487-2470
Paul Paris, MN Inventors Soc, 20231 Basalt Street, NW, Anoka, MN 55303	(612) 753-2766
James Babcock, Sci & Tech Center, Southwest State University, Marshall, MN 56285	(800) 642-0684
Fred Amram, General Coll, U of MN, 240 Appleby Hall, Minneapolis, MN 55455	(612) 625-2531
Marge Braddock, Inventors Club of MN, PO Box 14775, Minneapolis, MN 55414	(612) 331-2718
James Swiderski, MN Proj Innvnt, 1200 Washington Ave S, S M-100, Mpls, MN 55415	(612) 338-3280
Bob Gillson, Inventors & Designers Network, PO Box 8, Pillager, MN 56473	(218) 746-3638
Penney Becker, MN Inventors Congress, PO Box 71, Redwood Falls, MN 56283	(800) 468-3681
Helen Saatzer, MN Inventors, PO Box 335, St. Cloud, MN 56302	(612) 253-2537
Bill Baker, Inv & Des Ed. Assoc., PO Box 268, Stillwater, MN 55082	(612) 430-1116
Frank Seibert, MO Inventors, UMO, 1800 University Place, Columbia, MO 65211	(314) 882-7096
Dr. Jerry Udell, Innovation Institute, Route 2, Box 184, Everton, MO 65646	(417) 672-3217
Bob Sherwood, Innovation Dev, 4747 Troost Avenue, Kansas City, MO 64110	(816) 531-8494
Ed Stout, Mid-America Inventors, 2018 Baltimore, Kansas City, MO 64108	(816) 221-2442
Bobby Toole, Prof Invention Coun, Box 50294, St. Louis, MO 63105	(314) 721-2005
John Amos, Ctr Tech Dev, UMO, Bldg. 1, Nagogami Terrace, Rolla, MO 65401	(314) 341-4559
Dennis Roedemeier, MO Enterprize Center, 800 West 14th Street, Rolla, MO 65401	(314) 364-8570
Sidney Shage, St. Louis Inventors Assc, PO Box 16544, St. Louis, MO 63105	(314) 432-1291
Bernie Sarbaugh, Central MO State U, Grimstead Bldg. Room 86, Warrensburg, MO 64093	(816) 543-4111
James Smith, MS Sci & Inv Soc, 1503 Rosemont Drive, Clinton, MS 39056	(601) 924-8607
Tom Howe, IWIEF, 1021 Cedar Hill Drive, Jackson, MS 39206	(601) 362-2968
Eric Rommerdale, MS Inventors Soc. Box 5111, Jackson, MS 39296	(601) 984-6047
Ed Waters, Meridian IWIEF, PO Box 4398, Meridian, MS 39304	(601) 483-8241
Frank Wilem, Gulf Coast Breeder, 109 E. Science Dr, Pass Christian, MS 39571	(601) 452-2007
Charles Moore, Am Ent Dentist soc, 420 Magazine Street, Tupelo, MS 38801	(601) 842-3801
W.T. George, Yellowstone Inventors Assc, Box 23306, Billings, MT 59104	(406) 259-9110
Stephen Huntington, MT Scitech Alliance, 46 N Last Chance Gulch, S 2B, Helena, MT 59620	(406) 449-2778
Fred Davison, Montana Inventors Association, RR #1, Box 37, Highwood, MT 59450	(406) 733-5031
Bruce Gjovig, Innovation Dev Cen, Box 8103 University Station, Grand Forks, ND 58202	(701) 777-2339
Dave Watt, ERIP/SBIR, Box 8103 UND Station, Grand Forks, ND 58202	(701) 777-3132
Stuart McDonald, ND Inventors Congress, Box 1530, Jamestown, ND 58401	(701) 252-4830
Steve Buttress, Kearney Dev Council, 2001 Avenue A Box 607, Kearney, NE 68847	(308) 237-3101
Herb Hoover, Nebraska Tech Ctr, W 191 Nebraska Hall, UN Lincoln, Lincoln, NE 68588	(402) 472-7211
Steve Williams, NE Economic Dev, PO Box 94666, Lincoln, NE 68509	(800) 426-6505
Dan T. Waldrop, Omaha Inventors Club, Biddle Tech, 15869 Ohern, Omaha, NE 68135	
John Gilmore, National Inventor Soc, Box 434, Cranford, NJ 07016	
Lawrence Jay Schmerzler, National Inventors Soc, Box 434, Cranford, NJ 07016	(201) 763-6197
Calvin MacCracken, Calmac Mfg, 101 West Sheffield, Englewood, NJ 07631	(201) 569-0420
Janet Holloway, State SBDC Director, 180 University Avenue, Newark, NJ 07102	(201) 648-5621
George Sanders, High Tech Coun, 4550 S. Maryland Pkwy, Unit P, Las Vegas, NV 89119	(702) 736-6775
Don Costar, NV Inventors Association, Box 9905, Reno, NV 89507	(702) 322-9636
Gus Zuzo, President, NITEC, PO Box 60220, Reno, NV 89506	(702) 673-7388
Phil Knapp, NY Inventors Society, 116 Stuart Avenue, Amityville, NY 11701	(516) 598-3228
Robert Bassett, Batavia IWIEF, 126 Grandview Terrace, Batavia, NY 14020	(716) 343 1946
JE Manuel, NY Inventors, SUNY Farmingdale, Lupton Hall, Farmingdale, NY 11735	(516) 331-3606
Chris Novell, NY IWIEF, RFD 2, Box 127, Granite Springs, NY 10527	(914) 248-5362
William Wild, Western NY Tech Dev Ctr, 200 Harrison Street, Jamestown, NY 14701	(716) 661-3336
Ray DiPietro, Syracuse IWIEF, 205 S. Central Avenue, Minoa, NY 13116	(315) 656-9210
Harry Hawkins, Tech Trans Ctr, SUNY, 209 Park Hall, Oswego, NY 13126	(315) 341-2128
Jenny C. Servo, West NY Inventors Society, PO Box 23654, Rochester, NY 14693	
Kimou Louvaris, Pan Hellenic Society, 2053 Narwood Avenue, S Merrick, NY 11566	(516) 223-5958

## INVENTOR'S ASSOCIATIONS (NC-WY)

Society of American Inventors, PO Box 7284, Charlotte, NC 28217	
Bob Park, INVENT-NET System, PO Box 489, Four Oaks, NC 27524	
Tom Hollingsworth, Nat Inv Hall of Fame, 80 W Bowery, Suite 201, Akron, OH 44308	(216) 762-4463
Ned Oldham, Akron Inventors, 1225 West Market Street, Akron, OH 44240	(216) 864-5550
Ron Docie, Ohio Inventors Association, 3 Pine Place, Athens, OH 45701	(614) 594-5200
Bob Abernethy, Inventors Connection, Box 360804, Bedford, OH 44136	(216) 226-9681
Louis Kohus, Cincinnatti Inventors Soc, 1312 Mayland Drive, Cincinnatti, OH 45150	(513) 576-1200
Connie Menefee, Cincinatti Inventors Interface, PO Box 3503, Cincinnatti, OH 45201	
William S. Selenke, Cincinatti, 18 Gambier Circle, Cincinatti, OH 45218	(513) 825-1222
Advanced Ind. Prods, Battelle Memorial Inst, 505 King Street, Columbus, OH 43201	(614) 424-6424
Paul Cover, Columbus Inventors Network, 1445 Summit Street, Columbus, OH 43201	(614) 291-7900
Richard Hill, 1839 Victorian, Columbus OH 43220	(614) 292-1993
Inventor's Network, 1445 Summit, Columbus OH 43201	(614) 291-7900
Tim Nyros, Columbus Inventors Assoc., 2480 East Avenue, Columbus, OH 43402	(614) 267-9033
George Pierce, Invention Engineering, 27 Aberdeen Avenue, Dayton, OH 45419	(513) 293-2770
George D. Price Jr, Dayton Inventors, Box 9488, Dayton, OH 45409	(513) 224-8513
B. Jean Stamm, Dayton Inventors, 140 East Monument Avenue, Dayton, OH 45402	(513) 439-4497
Rich Schoenberger, Lorain Inventors, Lorain College, 1005 N Abbe Road, Elyria, OH 44035	(216) 365-7771
Michael Jay, OH Tech Trans, Terra Tech College, 1220 Cedar Street, Fremont, OH 43420	(419) 334-8400
Richard L. Wantz, Kessler Sales Corporation, 1247 Napoleon Street, Fremont, OH 43420	(419) 334-2793
Charlie Clark, Yankee Ingenuity Program, 623 Grant Street, Kent, OH 44240	(216) 673-1875
Sherri Chinistor, Rural Enterprises, PO Box 26980, Oklahoma City, OK 73126	(405) 841-5148
William L. Enter, Invention Devl Soc, 8230 SW Eighth Street, Oklahoma City, OK 73128	(405) 376-2362
Floyd Farha, OK Inventors Asst, OK Commerce, Box 26980, OKC, OK 73126	(405) 843-9770
Albert Janco, Oklahoma Inventors Congress, Box 18797, Oklahoma City, OK 73154	(405) 848-1991
Tom Mosley, New Prod Devel, OK Commerce, PO Box 26980, Oklahoma City, OK 73126	(405) 841-5130
Kenneth Addison, OK Inventors, PO Box 27291, Tulsa, OK 74149	(918) 245-6465
Dale Davis, OK Inventors Association, 11911 East 20th Street, Tulsa, OK 74128	
John A. Beaulieu, OR Res & Tech Devel Co, 1934 NE Broadway, Portland, OR 97232	
Richard Lavallo, Portland IWIEF, 2387 NW Kearney, Portland, OR 97210	(503) 227-4195
Dave Hopfer, Salem IWIEF, 2876 Cloverdale Road, Turner, OR 97392	(503) 743-2002
Robert K. Jordan, NW Inventors Council, Gannon University, Erie, PA 16541	(814) 871-7619
Robert Light, PA Inventors, Res & Ind Progs, PSU, Station Road, Erie, PA 16563	(814) 898-6000
Henry Skillman, American Inventors Soc, Box 58426, Philadelphia, PA 19102	(215) 546-6601
Eduardo Carbonell, PR Economic Dev Adm. GPO 2350, San Juan, PR 00936	
Oscar Prieto, PR Products Assoc., GPO Box 3631, San Juan, PR 00936	
Bruce Lang, RI Tech Sci Partnership, 7 Jackson Walkway, Providence, RI 02903	
William C. Chard, Emerging Tech Ctr, Clemson U, Box 5703, Clemson, SC 29634	(803) 646-4020
Olivia Mixon, SC Inventors Association, 222 Terrace Way, Columbia, SC 29205	(803) 799-0631
Barry Wilfahrt, Watertown Chamber of Commerce, Watertown, SD 57201	(605) 886-5814
Dorothy Duncan Johns, TN Inventors, Box 11225, Knoxville, TN 37939	(615) 690-3109
David Patterson, TN Tech Fnd, 10915 Hardin Valley Rd, Knoxville, TN 37932	(615) 694-6429
Edgar Cole, TN SBDC SW Regional Office, MSU, 320 South Dudley, Memphis, TN 38104	(901) 678-2041
Veronique Berardino, Austin Inventors, 6714 Spicewood Springs Rd, Austin, TX 78759	(512) 346-7129
Tim Bigham, Austin Inventors, 1418 Fairwood Road, Austin, TX 78722	(512) 451-8871
Laura Killcrease, Austin Tech Incubator, 8920 Business Park Dr, Austin TX 78759	(512) 794-9994
Harold Livesay, History Dept, Texas A&M, 507 Arrington, College Station, TX 77843	(409) 845-7107
Jan Casner, Richardson Ind. School District, 7643 La Manga, Dallas TX 75248	(214) 448-2850
Tom E. Workman, Texas Inventors Assn, 4000 Rock Creek Dr, #100, Dallas, TX 75204	(214) 528-8050
Bruce Davis, Toy & Game Inventors, 5813 McCart Avenue, Fort Worth, TX 76133	(817) 292-9021
Wessie Cramer, Am Inv Network, 11518 Paramount Lane, Houston, TX 77067	(713) 650-0645
John R. Kirk, Jr PC, 3555 Timmons, Suite 700, Houston, TX 77027	(713) 621-2021
Kenneth A. Roddy, Houston Inventors, 2716 WTC Jester Blvd. Ste. 108, Houston, TX 77018	(713) 686-7676
Art Ramseur, 1250 NE Loop 410, S 505, San Antonio, TX 78209	(512) 828-4932
Karen Stewart, Commission on Economic Development, 777 South State, Orem, UT 84058	(801) 226-1521
Norman Brown, Technology Targeting 2940 S. Warr, Salt Lake City, UT 84109	(801) 487-9800
Ed Ravigar, VP, Intermountain Inv Soc, 5770 Minden Drive, SLC, UT 84121	
John Winder, Intermountain Soc. of Inventors, Box 1514, Salt Lake City, UT 84110	(801) 571-2617
Donald G. Weinert, Nat Soc Prof Engrs, 1420 King Street, Alexandria, VA 22314	(703) 356-6851
Invent America!, 1420 King Street S 420, Alexandria VA 22314	(703) 684-1836
Donald G. Kelly, PTO/DOC, PO Box 2863, Arlington, VA 22202	
David Lux, History Department, VA Polytechnical Inst, Blacksburg, VA 24061	(703) 231-5155
Don Overly, CRC VA Polytechnic Inst. & State U., 1800 Kraft Drive, Blacksburg, VA 24060	(703) 231-6000
Michael Miller, Innov Tech Ctr, 2214 Rock Hill Rd CTI Bldg. S 600, Herndon, VA 22070	(703) 689-3000
Henry B. Ehrhardt, NW Inventors Assoc., 723 East Highland Drive, Arlington, WA 98223	
David V. Sires, Inventors Assoc. of Washington, PO Box 1725, Bellevue, WA 98009	(206) 453-0860
Hoanne Slaybaugh-Taylor, Innov Assmt, SBD, 245 Todd Hall WSU Pullman, WA 99164	(509) 535-1576
Raymond Watts, Tech Integration, Batelle Pacific Northwest, Box 999, Richland WA, 99352	(509) 376-4348
Paul van Minden, Innovators Internat'l Project, PO Box 4636, Rolling Bay, WA 98061	
Herb Kierulff, Kierulff Associates, 815 West Argabd Street, Seattle, WA 98119	(206) 285-1583
Ed Rosage, Tacoma IWIEF Chapter, 2702 40th E., Tacoma, WA 98404	(206) 922-9032
Steve Henry, Midwest Inventors Group, Box 518 or 1, Chippewa Falls, WI 54729	(715) 723-5061
Rich Derks, WI SBDC, U of WI, 432 North Lake Street, Madison, WI 53706	(608) 263-7766
Jim Frymark, Technology Development Fund, WI Dev Dept, Madison, WI 53707	(608) 273-3690
Donald Westerman, Research & Resource, 8701 Watertown Plank Rd, Milwaukee, WI 53226	
Dr. John F. Entorf, Center of Innovation & Development, U of WI, Stout, WI 53190	(715) 232-1122
Debra Know-Malewicki, WI Innovation Ctr, 402 McCutchan Hall, Whitewater, WI 53190	(414) 472-1365
Kay Stucker, US Small Business Admin., PO Box 2839, Casper, WY 82602	(307) 261-5761

trade groups, scholarly organizations, on-line resources (especially Dialog), and industry shows.

(E) You must be very aware of the political, legislative, competitive, and marketing realities of the target field.

(F) You must be in an area where innovation by individuals on a small scale is welcomed, rather than being regulated, legislated, or adjudicated excessively. Put another way, if it is automotive, forget it.

(G) Your preproduction prototypes must be in or beyond their advanced beta testing stage and have to clearly fill some unique need or perceived need in the mind of the end user. And, of course...

(H) You must studiously and very religiously avoid any and all contact with the patent system in any way, shape, or form.

I very strongly feel that omitting *any* of these core requirements can cause your new idea or concept to fail. And many users of those wolf resources fail on *all* counts, let alone on just a few of them.

### The Sheep

The sheep are the actual inventors themselves. There are hundreds of local inventor's organizations and clubs. Some will stand on their own. Others are the individual chapters of state-wide umbrella organizations.

The quality and utility of a local sheep group can vary all over the lot. Some can give you genuinely useful contacts and unique access to lots of otherwise unavailable resources. But others might be dominated by one or two strong personalities clearly a few chips shy of a full board. Yet others are pretty much the equivalent of a gambler's action committee that is lobbying for anti-static casino rugs and more comfortable slot machine handles.

By and large, many of these sheep organizations can be highly useful resources. But they often will fail to address all the key idea development issues. Which are...

(A) The tendency to grossly and obscenely overvalue unproven and undeveloped ideas; to assume that patents are somehow central to idea

---

creation and marketing rather than an avoidable, costly, risky, and largely unneeded sideshow; and to assume that others are as excited as you are about your product or will place your interests over their own.

(B) Failing to recognize that a patent is *only* the legal right to sue someone in a costly civil action; that very few patents ever show a positive net cash flow; and that even fewer patents are unbustable by a diligent enough search for prior art in obscure enough places.

(C) Not recognizing that the *only* three responses to a "you are violating my patent" letter is to ignore the letter; to bust the patent; or to obsolete the technology. Besides the side effects of permanently pissing off your potential best customer and making yourself an enemy for life. The unthinkable possibility of voluntarily paying patent royalties just doesn't come up.

(D) To assume that big industry (especially Fortune 500 companies) are actively seeking new products. In reality, most large organizations studiously avoid all change and categorically refuse to look at *any* outside submissions because of potential liability hassles. Innovation *always* comes from individuals and smaller firms.

(E) Trying to play for the spectacular (and nonexistent) big win, rather than accepting simple and solid returns over and over again. An average well developed idea should typically return around \$400 or so. If you are playing at million to one odds, then you don't want to put more than a dollar of time or effort up for every potential million in expected returns.

(F) Assuming that others are willing to pay more for a mythical and unproven sheet of paper instead of buying the solid risk reduction of delivered and beta tested working pre-production prototypes and ready-to-use artwork.

(G) Forgetting that not less than 95 percent of any survivable patent search must be done in the industry trade journals, scholarly publications, and on-line resources. The patent system is the *last* place to look for prior art.

(H) Failing to recognize that trying to profit from the patent system takes a lifetime total commitment to courts and courtrooms, lawyers and legal hassles. Compared to lots of creative and useful time spent in the lab actually developing and improving products.

I suspect that there are a lot more sheep groups than we have shown. When we cleaned the list, a very few asked not to be included. Well, one actually. He assumed I was ripping him off. And several other listed ones prefer a low profile and asked their phone be omitted. Let me know of any local or obscure sheep groups that you run across.

### The Shepherds

The shepherds are the bureaucrats. Government entities who promote inventions and inventing. Often for their own greater glory and aggrandizement. And, as real shepherds, they sometimes will fleece their flock. Or eat them.

The shepherds could be university or college based. Or federal and state government. Or else local chamber of commerce and science fair groups.

I guess the worst things I've got against the shepherds is that they lack an utter and total sense of reality since they are dealing with other people's money, and that they are directly responsible for perpetuating all of the outrageously absurd myths that surround inventions and inventing.

They also tend to do all the wrong things for the wrong people for the wrong reasons. And, almost always, they'll cost far more than they deliver.

Properly used and recognized for what they are, though, these shepherd groups can be a most valuable and useful resource to you as a Midnight Engineer.

### The Watchdogs

The final group is much smaller than the others. The watchdogs have dedicated themselves and their lives to protecting the sheep from all of the wolves. And from the shepherds as well. These are lone individuals running data base and newsletter "supergroups" that collect and compile and advise the other groups.

I now know of only two watchdogs and they both do exceptionally good work: Bobby Toole of *Professional Invention Counseling* and Raymond Watts of the *Inventors Assistance Program*. Note that their watchdog services are primarily for inventor's *organizations* and *not* specifically for lone individuals.

Special thanks to Bobby Toole, whose old original list was carefully updated and cleaned for our directory here.

### For More Info

Although I have spent an awful lot of time and effort verifying these names and numbers, a few bugs are likely to remain. Please let me know about any problems that may crop up. I'll upload the corrections on-line.

I have posted our inventor's organizations sidebar to my *GENIE* PSRT as file *INVENORG.PS*. You'll also find more in *#477 NOPATENT.PS* or my *#162 NOPATENT.TXT*. The typical downloading costs are around twenty cents each. You could get your voice connect info by dialing (800) 638-9636. And, of course, bunches more on viable, proven, and successful alternatives to patents and patenting appear in my revised and updated *Incredible Secret Money Machine II*, available per my nearby *Synergetics* ad.

At this writing, an attempt is being made to convert the patent system into a "first to file" fiasco. Otherwise known as the *Patent attorney and patent examiner's relief act of 1992*. I am very much in favor of this legislation in that it will once and for all stamp out any remaining vestige of credibility of the US patent system, at long last revealing it for the utter and total ripoff it is for virtually all lone individuals and Midnight Engineers. ♦

---

*Microcomputer pioneer and guru Don Lancaster is the author of 27 books and countless articles. Don maintains a no-charge technical helpline you'll find at (602) 428-4073, besides offering all his own books, reprints, and various services. Don has a free brochure chock full of his new insider desktop publishing secrets waiting for you. The best calling times are 8-5 weekdays, Mountain Standard Time.*

*Don is also the sysop of GENIE PSRT (800) 638-9636 where a special area has been set aside for you Midnight Engineering readers. Or you can reach Don through his Synergetics, at Box 809, Thatcher, AZ 85552.*





Don Lancaster's

# RESOURCE BIN

number fourteen

## Starting up your own technical venture.

**O**ur usual reminder here that the *Resource Bin* is now a two-way column. You can get tech help, consultant referrals and off-the-wall networking on nearly any electronic, *tinaja questing*, personal publishing, money machine, or computer topic by calling me at (602) 428-4073 weekdays 8-5 MST. I've got a free pair of insider secret resources brochures waiting for you when you call or write.

A portion of my PSRT RoundTable on *GENie* has also been set aside for you *Nuts & Volts* readers. This is the place to go for instant tech answers. Among the many files in our library, you will find complete reprints and preprints for all of my *Resource Bin* columns. You can call (800) 638-9636 for your voice connect info.

By the way, *GENie* has just made two major improvements: There are now 800 numbers for those of you who live in really remote areas. A brand new visual screen interface makes things faster and friendlier for Mac users. PC users have already had the automated *Alladin* system in place.

I'm deeply saddened by the local version of *Elector Electronics* shutting down after only twenty some issues. The immediate causes seemed to be ads which cost too much and projects perceived as "too European".

Nonetheless, they published more hacker projects and better thought out hacker projects in each issue than just about anyone. Some back issues do remain in stock.

The European edition of *Elector* is still available.

There are bunches of good hacker mags left, though. You've probably figured out by now that *Nuts & Volts* has by far the widest selection of ad resources and has greatly expanded its construction projects and technical info columns.

The oldest continuously published newsstand magazine with the most

advanced tech coverage remains *Radio Electronics*. They've recently renamed themselves as *Electronics Now*. Their sister publication *Popular Electronics* is more for the beginners and low end projects. But note that this is *not* the one-and-only uniquely original PE of "Carl and Jerry" fame; only the name still remains.

Steve Ciarcia contunes to publish his *Circuit Cellar Ink*, which is big on embedded controllers and computer aps. Like *Elector*, his projects are all thoroughly tested, well supported, and carefully developed. Most are also available as high quality kits.

The U.S. republishers of *Elector* do continue offering several well done specialty audio electronics magazines. These include *Speaker Builder*, *Audio Amateur*, and *Glass Audio*. The latter is for people still using vacuum tubes for their amplifiers.

To me, if you want to get a "tube sound", you just take a decent solid state amp and add some extra noise, hum, and distortion. Then you give yourself some second degree burns in embarrassing places. Similar to the ones caused by getting too personal with a 6L6GTB. The morphine-like endorphins released by the brain in

**NEXT MONTH: Don reveals his professional prototyping tips, tricks, and techniques.**

response to the burn pain seem to be the primary cause of the perceived sound differences.

Let's see. We've already covered the labor-of-love technical newsletters in the previous columns and in my ongoing *Resource Bin* reprints. And I will get around to the ham magazines sometime. Five other magazines of hacker interest include Forrest Mim's *Science Probe*; *Midnight Engineering* for

technical startups; *Whole Earth Review* for access to tools; Jeff Duntemann's great *PC Techniques*; and *Electronic Servicing* for handling all of your own consumer electronics repairs.

### Are things really that bad?

It is real easy to get very depressed over the current hacker scene. A fine magazine has died. Heathkit has more or less folded. Although they do still offer some educational stuff. Several major tech book publishers are only the hollowest shadows of their former selves. Nearly all backlist titles have vanished entirely. Alarmingly, many community colleges are dropping their electronics programs entirely. Or sharply scaling back.

But the worst of all is the following horror story: I walked into Safeway and saw an "All paperback books 25 percent off" sign. I got to the register and a checkout person tried to charge me the full \$5.99. To make a long story short, I suggested I had this oddball hunch that the correct price might lie somewhere around \$4.49.

Two checkout persons, a bagger, an assistant manager, and even the store manager were *totally unable* to figure out just how much to charge me. After fumbling around for a quarter hour, they finally used my wild guess. They also were *totally unable* to determine how much vendor credit was needed to reconcile the register totals. As a wild stab in the dark, I told them I did feel that \$1.50 might come close.

Naturally, I got blamed for all of this. I was this here problem that had to be dealt with. Who was obviously ruining their day. And making them look real dumb to their boss. Yes, I was very polite.

It just never occurred to any of the Safeway employees that there was this thing known as "math". Or that you could do this math stuff without using any special machines. In your

head, even. One quarter of sixty is fifteen. Times three is forty five. A fraction of a penny is still a penny.

Or that far too many people still spend way too much time vegging out on that tapioca pudding scene in *Godzilla versus the Night Nurses*.

James Glick makes an observation on where all the American technical excellence of the earlier decades has come from. In his well done *Genius* biography of Richard Feinmann, he points out that practically all of the older engineers and scientists got that way by tearing apart table radios, fixing and modifying them along the way. Skills that any reasonably swift seventh grader could have very easily picked up on their own.

If this country is in fact going to hell in a handbasket, then there are obvious emerging opportunities in handbasket creation and distribution. Everybody will now want one. Get in ahead of the hoarders.

The other side of the coin, of course, is that we are now sitting on the most incredibly stupendous new collection of hardware and chips and systems and software. Many lifetimes could not even remotely begin to even start to exploit what we've now got.

So, what's in all of this for you? More specifically, just how do you go about starting...

### Your very own venture

In the real world, the perception is the reality. Under no circumstances would you ever decide to volunteer that you were a student or a hacking hobbyist or a small scale startup. And *never* say that I sent you. That's almost as dumb as purposely calling yourself an inventor.

Only when and where absolutely necessary, you'll want to cause "them" to think they heard what they thought they wanted to hear. For "them" is in business to sell stuff. And "them" will show interest in you only as long as you appear to be a potential buyer.

Or in fact become one.

So, the best method to unstack the odds against yourself is to set up your own smaller technical business. The main reasons you would want do this initially is just to be able to qualify for those crucial free trade journal subs, and to provide some apparently valid place to receive data books and other useful tech info.

Much more on this in the *Resource Bin* reprints. Later on, you can worry about such things as actually doing

"real" business activities or even trying to make a profit.

Anyone could quickly and cheaply start their own technical business. I feel that the best startup form is called a *proprietorship*, otherwise known as "The business is you". Depending on where you live, your startup costs can be well under \$50.

First, you go off to your Secretary of State's office at your state capitol, or else play several rounds of telephone roulette with them. In Arizona, what you want is known as the *Trade Names Registry*. In this, you want to place the name for your new enterprise. They will probably insist that nobody else is using the name, and that the name is not deceptive or obscene. Although a local boiler room diamond scam did get away using "DeBeers" hoping the marks would confuse them with the real "DuBeers" diamond consortium.

You'll want to pick out something flexible and rather vague, high tech sounding, and expressing a "funkily cautious optimism".

Whatever that is.

My original trade name choice was *Synergetics*, largely because I do very much believe in Buckminster Fuller. But I have had several scam operators try to steal this name for everything from Oriental Rug ripoffs to hot office products. Later, when I became a "real" book publisher (You wouldn't believe the high you get over seeing your first ISBN number in real ink!), I added my *Synergetics Press*. There's apparently another *Synergetics Press* in Tennessee, but our paths don't seem to cross all that often. And the master ISBN directory carefully warns each about the other.

Bee registered Abeja, whose utter and profound significance becomes apparent to anyone with even the slightest smattering of espanol. She will sometimes go by *Abeja Associates* or *Abeja Discount Software*.

Some of the others around here are starting to look more and more like a free form Medieval guild. And all the much better for it.

Kathy St. George selected *Special Editions* for all her PostScript desktop publishing and script writing. Henry and Lamel Schneiker have used *HDS Systems* for their software consulting and multimedia productions. While Kate Daniel (my assistant sysop on *GEnie PSRT*) uses *Dantech*.

In Arizona, the costs are \$25 for a five year registration. In certain high tech parts of the country, a city or a

## new from DON LANCASTER

### ACTIVE FILTER COOKBOOK

The sixteenth (!) printing of Don's bible on analog op-amp lowpass, bandpass, and highpass active filters. De-mystified instant designs. \$24.50

### CMOS AND TTL COOKBOOKS

Millions of copies in print worldwide. THE two books for digital integrated circuit fundamentals. About as hands-on as you can get. \$24.50 each.

### INCREDIBLE SECRET MONEY MACHINE II

Updated 2nd edition of Don's classic on setting up your own technical or craft venture. \$18.50

### LANCASTER CLASSICS LIBRARY

Don's best early stuff at a bargain price. Includes the CMOS Cookbook, The TTL Cookbook, Active Filter Cookbook, Micro Cookbooks I & II, newly revised Incredible Secret Money Machine II, and those Hardware Hacker II reprints. \$119.50

### LOTS OF OTHER GOODIES

Ask the Guru I or II or III .....	\$24.50
Hardware Hacker II or III .....	\$24.50
Book-on-Demand Resource Kit .....	\$39.50
PostScript Beginner Stuff .....	\$39.50
Intro to PostScript Video .....	\$39.50
GEnie PSRT Sampler .....	\$29.50
PostScript Reference II .....	\$28.50
PostScript Tutorial/Cookbook .....	\$18.50
Whole works (all PostScript) .....	\$350.00
PostScript Secrets Brochure .....	FREE
Hacking Secrets Brochure .....	FREE

### POSTSCRIPT SECRETS

A Book/Disk combination crammed full of free fonts, insider resources, utilities, publications, workarounds, fontgrabbing, more. For most any PostScript printer. Mac or PC format. \$39.50

### BLATANT OPPORTUNIST I

The reprints from all Don's Midnight Engineering columns. Includes the case against patents, book on demand publishing, toner secrets, paradigm stalking, insider research, lots more. \$24.50

### RESOURCE BIN I

A complete collection of all Don's Nuts & Volts columns to date, including a new index and his master names and numbers list. \$12.50

### FREE SAMPLES

Well, nearly free anyway. Almost. Do join us on GEnie PSRT to sample all of the Guru's goodies. The downloading cost on a typical Guru file is 21 cents. Call (800) 638-9636 for connect info.

FREE VOICE HELPLINE VISA/MC

**SYNERGETICS**  
Box 809-NV  
Thatcher, AZ 85552  
(602) 428-4073

Write in 146 on Reader Service Card.

## RESOURCE BIN NAMES & NUMBERS

### Abeja

3860 West First Street  
Thatcher, AZ 85552  
(602) 428-4073

### Audio Amateur

PO Box 876  
Peterborough, NH 03458  
(603) 924-9464

### Blanks USA

2722 Fernbrook Lane N  
Minneapolis, MN 55447  
(800) 328-7311

### Cards Now

6401 Odana Road  
Madison, WI 53719  
(800) 233-9767

### Circuit Cellar, Ink

4 Park Street, Ste 20  
Vernon, CT 06066  
(203) 875-2751

### Dantech

PO Box 1856  
Benson, AZ 85602  
(602) 586-7050

### Elector Electronics BV

Postbus 75, 6190 AB BEEK  
The Netherlands  
011 31 4638 9444

### Electronic Servicing

PO box 12487  
Overland Park, KS 66282  
(913) 492-4857

### Electronics Now

500-B Bi-County Road  
Farmingdale, NY 11735  
(516) 293-3000

### GENie PSRT

401 N Washington St  
Rockville MD 20850  
(800) 638-9636

### Glass Audio

PO Box 876  
Peterborough, NH 03458  
(603) 924-9464

### HDS Systems

PO Box 42767  
Tucson, AZ 85733  
(602) 325-5884

### Hello Direct

140 Great Oaks Blvd  
San Jose, CA 95119  
(800) HI-HELLO

### Int. Std. Periodical Guide

150 Fifth Ave #202  
New York, NY 10011  
(212) 741-0231

### Midnight Engineering

1700 Washington Avenue  
Rocky Ford, CO 81067  
(719) 254-4558

### Nuts & Volts

430 Princland Court  
Corona, CA 91719  
(714) 371-8497

### Paper Direct

57 Romanelli Avenue  
S Hackensack, NJ 07606  
(800) A-PAPERS

### Paper Plus

300 Oceangate #800  
Long Beach, Ca 90802  
(213) 436-8291

### PC Techniques

7721 E Gray Road #204  
Scottsdale, AZ 85260  
(602) 483-0192

### Popular Electronics

500-B Bi-County Blvd  
Farmingdale, NY 11735  
(516) 293-3000

### Queblo

131 Heartland Blvd  
Brentwood, NY 11717  
(800) 523-9080

### Science Probe

500-B Bi-County Blvd  
Farmingdale, NY 11735  
(516) 293-0467

### Speaker Builder

Box 494  
Peterborough, NH 03458  
(603) 924-9464

### Special Editions

PO Box 345  
Thatcher, AZ 85552  
(602) 428-7871

### Synergetics

Box 809  
Thatcher, AZ 85552  
(602) 428-4073

### Uhlricht's Periodicals

1180 Americas Avenue  
New York, NY 10016  
(212) 916-1600

### Whole Earth Review

27 Gate Five Road  
Sausalito, CA 94965  
(415) 332-1716

county registration might also be a good idea.

### Going further

A simple trade name registration is all you'll need to go into business for yourself. That's all there is to it.

Your next step is to go to the Post Office and add the name of your new company to the "alias list" or the "who resides there" card for your address, informing them that you will accept mail addressed to this new name. You keep this action as low key as you possibly can.

Also inform UPS and any express services that you are likely to use.

I feel that a separate post office box for your new venture is a very good idea. Here in Thatcher, it is the *only* route, as there is no home delivery.

At your bank, quietly add the new name to your signature card, and get yourself some checks printed up that include both your name and that of the business. Always start the new check sequence with number 4000 or higher. Again, do this as quietly and simply as you can.

With any of today's PostScript laser printers, it is utterly trivial to make up your own letterheads, stationary, and business cards. The cost is negligible, and you can do it yourself in minutes. Companies such as *Paper Plus*, *Paper Direct*, *Blanks USA*, *Cards Now*, and *Queblo* now offer you high quality full color blanks that you simply can't tell from the real thing. Lots of good examples are on my *GENie PSRT*.

You'll want to start answering your phone professionally, treating *all* calls as if they went to the switchboard of a Fortune 500 company. You can ease the burden on friends or family with email, selective ringing, or caller id. One source is *Hello Direct*.

Several things you probably do *not* want to do: One is to put a sign out front or let the neighbors know in any way that you've got a business. It is also *not* a good idea to tell the phone company, for your rates will go up.

The same goes for special business checking accounts.

From day one, you should keep accurate and meticulous records for all your business transactions. And

carefully separate the time and place you conduct your business from all of your other activities. The IRS defines the difference between a business and any hobby as "the genuine intent to show a profit" and "a conduction of affairs in a business-like manner".

Before you are allowed to deduct your business expenses, they require you to potentially show a profit at least two years out of five. Complete receipts and records are totally and absolutely essential here.

Certain hobbies, such as *Sears*, *IBM*, *Boeing*, or *Westinghouse* seem exempt from this two out of five rule. It sure would be interesting if they enforced the 2/5 rule as vigorously with the big hobby 500 firms as they do with the innovative small scale startups.

The IRS has recently gotten very ugly over the deduction of any home office space and costs. For instance, it is nearly impossible for any building contractor to try to deduct his home office expenses.

To get away with a home office deduction, this essentially has to be the *only* place you conduct business or meet *all* of your customers, and has to be clearly and exclusively dedicated as a work area. If you have *any* other employer, or if you go to somewhere else to do things for money, don't even think about a deduction.

I've found it pays to change your name slightly on most professional inquiries. So you can immediately sort business from pleasure. For instance, I consider "Donald E. Lancaster" to be unbearably stuffy. There is no way I would *ever* call myself that. Except to identify a professional request.

I've found that putting your phone in someone else's name (such as a wife's maiden name) is the ultimate in unlisted numbers. It also immediately separates the regular scams from the business ones.

Another trick that's revealed here for the very first time in print: *Never* answer the question "How are you today?" over the phone. *Say nothing!* The next person to speak *always* loses. People who are useful to you will go right on with their conversation, and never skip a beat. But those who are about to rip you off will pause and then lose their place in the script they are reading. Try it. This works 100 percent of the time.

### Your first activities

The very first thing you will want to do after your business is up and

running is go to the library and spend several *days* very carefully studying the *Standard Periodicals Guide* and *Uhlricht's Periodical's Dictionary*.

Pick several thousand likely trade journals and phone or mail *each* of them. Get a subscription qualification card. Assuming they are a controlled circulation publication. If not, request a sample copy and their advertising rate card. The SCAR technique.

Once you subscribe to a few trade journals, the rest of them will climb all over themselves desperately trying to get you to subscribe.

After these start pouring in, you use the bingo cards to instantly become a technically literate and an up-to-date industry insider.

### **For more information**

Scads more on all of this appears in my newly revised and self-published *Incredible Secret Money Machine II*, available per my nearby *Synergetics* ad. Autographed, even. And you can reach me electronically via *GENie* PSRT. Other *GENie* RoundTables of interest to you should include RADIO, IBM, MAC, HOSB (home office and small business), and DTP (desktop publishing). There's hundreds more where these came from. I've also got the no-charge voice helpline that you can access per the end blurb.

### **This month's contest**

Let's have three different contests for this month. If you are in any way involved with ham radio, please send me a copy of the table of contents and the masthead of any and all ham mags you know about. Especially any of the oddball and obscure stuff on packet, RTTY, amateur tv, weather sats, key collecting, crystal sets, QRP, antique electronics, and such. And maybe tell me why you do or do not like your particular choices.

Or, to test your "any old seventh grader" radio repair skill levels, just tell me the purpose for the filament tap on a 35Z5.

Or, if you are a Safeway employee, please send me a copy of the tapioca pudding scene in *Godzilla versus the Night Nurses*. Unsplattered copies of this cross-genre classic are getting real hard to find.

There will be some newly revised *Incredible Secret Money Machine II* books going to the dozen or so best (or earliest) entries, along with an all-expense-paid *tinaja quest* (FOB Thatcher, AZ) for two going to the

best of all.

Let's hear from you. ♦

---

*Microcomputer pioneer and guru Don Lancaster is the author of 28 books and countless articles. Don maintains his no-charge tech helpline found at (602) 428-4073, besides offering all of his own books, reprints, and all of his consulting services. He also has a free brochure full of his resource secrets waiting for you. Your best calling times are 8-5 on weekdays, Mountain Standard Time.*

*Don is now the sysop of GENie PSRT, where a special Resource Bin topic has been reserved for Nuts & Volts readers. You can contact GENie at (800) 638-9636 (voice) for connect info. Or you can reach Don at Synergetics, Box 809, Thatcher, AZ 85552.*

# Insider Research Secrets

**S**itting around and dreaming up new ideas all day long is a thankless task, but someone's got to do it. The key secret to positively brilliant new products is to develop a thousand of them at a time, and then throw away the 998 that don't meet spec.

There are some strong points that can be made for solo research. For soloing is doing everything from square one originally and by yourself. This could give you a different perspective and lets you ignore preconceived notions of others. It lets you head out in non-obvious directions. It lets you do your things the way you want to.

On the other hand, finding out what others have done before you can save you a lot of grief. There might be ideas you simply haven't thought of. Or fundamental physical laws which just can't be ignored. Or societal and political restrictions. Or going heads-up against an existing strong competitor. Worse yet, your great new product may already be scrounging lost and forgotten under the bargain counter of [Vinnie's Surplus and Distress](#).

A long ago ferinstance or two: Back in the early sixties, counting flip flops at long last became available at a mere four bucks each. I wanted to do some pitch reference stuff with these and needed to answer the question "What is the minimum number of flip flops you need for an acceptable musical accuracy? This question is not trivial, since the frequencies are irrational numbers as related by the twelfth root of two for equal temperament.

So, I spent several long months using a humongously klutzy Olivetti programmable calculator and I eventually found the answer that (1) eight bits is enough, but (2) only when you use the wondrously magic sequence of 116, 123 ... 232. Full details are found in my [CMOS Cookbook](#).

Had I just looked around a little first, I would have found this magic sequence already published years before in the *Journal of the Audio Engineering Society*. While it sure was a lot of fun, I could have saved two months of work just by asking "Has anyone think about this before now?"

And I assembled my Pitch Reference and published it. And just before I was about to release it, I talked to a piano tuner person, and found several fatal flaws in the product. It turned out that these pitch tones must *always* be pure sinewaves, or the ear gets confused. And the high and low notes of a piano are *never* tuned to their correct pitch. Instead, your keyboard gets "stretched" to allow for the nonharmonic overtones of real strings.

Had I instead bothered to read the 1946 book *Piano Tuning and Allied Arts*, I would have easily found this out.

And saved bunches of time and effort in the process.

The odds are overwhelming that your "new" idea is not new at all and that many hundreds of people have done similar work before you. It is almost a certainty that you're overlooking something totally obvious any time you try to develop anything new.

So it always pays to research what has gone before you. Let us do a quick rundown of my key insider secrets to quickly, accurately, and cheaply researching just about any topic, technical or otherwise...

## The Research Continuum

First and foremost, research is something that you do continuously on a total lifestyle basis. You do not turn your research activities on and off. You *always* should be busy studying something.

The process of getting and piling up useful info should go on day in and day out. Then, when you really need some crucial info in a hurry, your research gathering skills will be honed sharp enough to quickly get useful results.

Some of the stuff I'm currently researching includes spread spectrum comm, toner release coatings, *Lepcon* solar energy, GPS satellite standards, shared SCSI laser printing, fuzzy data [curve fitting](#), telephone caller ID, cheap small scale [book production equipment](#), new VCR programming formats, and, of course, [tinaja questing](#). Give me a call if you can help along with any of these.

## The Greatest Resource

By far the single most useful and powerful research tool anywhere ever is a magic book on the reference shelf of your local library. You probably never even heard of it. It is called *Uhlrich's Periodicals Dictionary*.

Uhlrich's lists some 50,000 or so magazines. Many of these are called *trade journals*. And trade journals are where all the action comes down in any field. Trade journals are insider's secret resource sources. Since they cover only the newest, the hottest, and the best.

Directly, trade journals give you technical articles, the names-and-numbers lists, bingo-cardable ads, and annual directories. Indirectly, they lead you to reference materials, data books, ap notes, free samples, seminars, trade shows, consultants, and great heaping bunches more.

Examples of electronic trade journals include *E.E. Times*, *EDN*, *Electronic Design*, *Electronic Products*, *Electronic Components News*, *Electronics*, *RF Circuit Design*, and many hundreds more. The mechanical examples include *Machine*

Design and P.T. Design, and Design News.

To give you an idea of the incredible variety of trade journals out there, a few of the several hundred that I personally subscribe to do include *Fire Engineering*, *Food Service Product News* (a great diet magazine - just read it before every meal), that *Paper, Film, and Foil Converter*, *Pollution Equipment News*, *Textile World*, *Powder and Bulk Solids* (how is this gem for obscure?), *Quick Printing*, *Horse trader*, *Motion*, *HVAC News*, the *Medical Equipment Designer*, *Signcraft*, *Research and Development*, *NASA Tech Briefs*, *Hydraulics and Pneumatics*, *Tinaja Quester's New Product Digest*, *Appliance*, and *Speleonics*.

Sadly, *WET - The magazine of gourmet bathing* has long ago ceased publication.

Trade journals are never offered on newsstands and only rarely appear in libraries. These are *controlled circulation* magazines specially set up to qualify for the special postal rate. Subscriptions to most trade journals are free if you can create the illusion of appearing to be an industry insider and potential volume buyer for their paying advertisers. To qualify, you request a subscription qualification card and then tell them what they want to hear.

You'll have the best luck if you act professional. With a registered trade name, a logo, your formally answered telephone, and a laser printed business letterhead.

The SCAR technique is one useful ploy that can get you a copy of just about any magazine. Just call or write their ad department and request a Sample Copy and Ad Rates. Sometimes, this can also get you a free subscription.

Most trade journal publishers have dozens of titles in as many fields. So, it pays to get a complete list of everything they offer. Once you receive any one trade journal, the competitors will usually glomp on to you as well.

### Other Library Stuff

A lot of library work often ends up as a frustrating and monumental waste of time. But there are several other obscure library resources that cannot be ignored. One of these is the *Encyclopedia of Associations*. Just about any field has its insider clubs and professional organizations. Who offer meetings, contacts, tutorials, directories, shows, seminars, and specialty book sales.

Although that humongously big old *Thomas Registry of Manufacturers* now indexes just about anybody who makes anything, they tend to be out of date in any fast changing field. They also miss small hi-tech startups.

Another library reference that is almost magic is the *Science Citations Index*. Unlike other compendiums, this one lets you move forward through time. Anytime someone references something else in a bibliography, it goes into the index. Just start with the "horses mouth" docs for any field and follow them forward through time. Eventually newer authors will start repeating. You then use the *avalanche effect* to completely cover the subject area.

More details on other library research secrets appear in my newly revised *Incredible Secret Money Machine II*.

### The Dialog Information Service

Behind Uhlricht's, the second most important resource tool in the world is the *Dialog Information Service*. This is an online searching service that presents key abstracts and full text papers of just about anything from anywhere.

One tiny corner of Dialog is called *INSPEC*. This gives you some fifteen million or so on-line abstracts to anything that involves electronics, computers, or physics. There are many hundreds of other data bases instantly available from them.

At \$2 per minute, Dialog sounds expensive. But I've found it to be far and away the fastest and cheapest way to pick up technical info. Especially in any field you know nothing about. Dialog is the *only* on-line or BBS service that I willingly and gladly pay for.

While you can subscribe to Dialog yourself, it is usually best to work with your local librarian. They can do things much faster and better. And the price (and size) of a total Dialog reference manual set is outrageous.

### Getting Reprints

I keep getting these strange letters and helpline calls from people that live in "such a remote area" that they "just can't find" any reprints on anything. Since two of these "remote areas" have included Cambridge MA and Palo Alto CA, I've reluctantly concluded there are those of you out there who could not find a pig in a dishpan.

Well, here I am sitting on my sand dune in the middle of the Upper Sonoran Desert. I have never had any serious problems getting technical reprints on anything. Even on fire towers or when doing underground cave research by carbide light. So don't give me any "remote" bull.

In reality, you'll find three easy routes to technical reprints. The first of these is the *Interlibrary Loan Service*, which is available at any library just for the asking. This service is usually free or very low in cost. On the other hand, it can take a long time. And you sometimes will have to be persistent to get useful results.

The "standard" M1A1 Rev 0 reprint source is *UMI*, who used to call themselves *University Microfilms*. They have one each of everything in stock. All you have to tell them is the exact journal, author, and page numbers. Charges vary with the number of pages and the service speed.

Finally, Dialog offers full text reprints of many of their references, on line, by FAX, or by mail. This is usually your fastest route to a reprint, but it often costs much more.

### Technical Books

For serious research, technical books place a distant third behind trade journals and Dialog. As you may have found out, mall storefronts with a "bookstore" sign in front of them often end up less than useless. Libraries have a bias against technical paperbacks. And what you need may be on reserve or in circulation.

Technical books traditionally have taken a long time to publish, and often are horribly out of date before the ink is even dry. Many publishers push their own second rate titles, rather than letting you know about the real leaders in the field. And technical book clubs are usually set up to flush remainders and unselling dogs.

Nonetheless, for the fundamentals of any field, a solid tech book by a well known name-brand author can be a tremendous research help. Where can you go to get books if they aren't in libraries or mall bookstores?

Instead, watch out for *specialty direct mail booksellers* who have a vested interest in stocking only the very best titles in any field. I've covered hundreds of these in my



## SOME RESEARCH RESOURCES

**CompuServe**  
5000 Arlington Center Blvd.  
Columbus, OH 43220  
(800) 848-8199

**Computer Literacy**  
2590 North First Street  
San Jose, CA 95131  
(408) 435-1118

**Dialog Information Svcs.**  
3460 Hillview Avenue  
Palo Alto, CA 94304  
(415) 858-2700

**GENie**  
401 N. Washington St.  
Rockville, MD 20850  
(800) 638-9636

**Heathkit**  
P.O. Box 1288  
Benton Harbor, MI 49022  
(616) 982-3200

**Hewlett-Packard Manuals**  
19310 Pruneridge Ave.  
Cupertino, CA 94014  
(800) 752-0900

**Lindsay Publications**  
P.O. Box 583  
Manteno, IL 60950  
(815) 468-3668

**MIX Bookshelf**  
6400 Hollis St. Ste. 12  
Emeryville, CA 94608  
(800) 233-9604

**Nuts & Volts**  
P.O. Box 1111  
Placentia, CA 92670  
(714) 632-7721

**OpAmp Technical Books**  
1033 North Sycamore  
Los Angeles, CA 90038  
(800) 468-4322

**Radio-Electronics**  
500-B Bi-County Blvd.  
Farmingdale, NY 11735  
(516) 293-300

**Stanford Bookstore**  
135 University Avenue  
Palo Alto, CA 94305  
(800) 533-2670

**Synergetics**  
P.O. Box 809  
Thatcher, AZ 85552  
(520) 428-4073

**Thomas Registry of Mfrs.**  
1 Penn Plaza  
New York City, NY 10119  
(800) 222-7900

**Uhlrich's Periodicals**  
1180 Americas Avenue  
New York City, NY 10016  
(212) 916-1600

**University Microfilms**  
300 N. Zeeb Road  
Ann Arbor, MI 48106  
(800) 521-3044

**The Well**  
27 Gate Five Road  
Sausalito, CA 94965  
(415) 332-4355

**Whole Earth Review**  
27 Gate Five Road  
Sausalito, CA 94965  
(415) 332-1716

other columns and, especially, in my [Ask the Guru](#) and *Hardware Hacker* reprints. But two examples of note are *Lindsay Publications* for machine shop, early radio, and home science titles; and the *MIX Bookshelf* for electronic music and video production books.

Good technical walk-in bookstores are rather hard to find. Several outstanding West Coast examples seem to include *Computer Literacy*, *OpAmp*, and *Stanford Bookstore*.

If you have some favorite specialty book sources, please let me know via the helpline so we can pass them on. I would like to compile a country-wide list.

### What about patents?

As you may have noticed, I am very much down on patents and the patent process. Especially for *Midnight Engineers* and other small scale startups. Mainly because of the deeply ingrained and ludicrously absurd popular myths surrounding patenting. And secondly because patents are usually a monumental waste of time, energy, money, and sanity. See [BLAT06.PDF](#) or else my [Blatant Opportunist](#) reprints for more details.

At any rate, I have consistently found Dave Berg's stories in *MAD* magazine to have far better inventions and ideas in them than have ever appeared in the *Patent Gazette*. Most patents are pointless and dumb. Not to mention usually being highly unprofitable.

In three decades of research, I've only rarely found any time or place where reading a patent was of very much use to me. I strongly do feel that the signal-to-noise ratio of studying patents is ludicrously low and usually is flat out not worth the effort. At least most of the time.

Should you feel otherwise, patents appear in the *Patent Gazette*, in patent repositories in many larger libraries, and are narrowly reviewed in certain trade journals. Individual patent copies are available at low cost. [And free online](#)

One thing that could help bunches would be patents on CD ROM with a total fuzzy logic text searching ability. That could increase the signal-to-noise ratio enough to make the time spent worthwhile.

### Service and Repair Manuals

Some companies positively refuse to ever let an outsider anywhere near their service literature. Others are much more reasonable. Obviously, service and repair info can give you lots of useful clues to just how others are solving problems similar to yours.

The greatest source of this sort of stuff, of course, is *Heathkit*. For years, you could buy the assembly manual and schematic for any simple electronic project for five bucks or so. Their real heavy duty projects did cost a tad more, but certainly were worth the price.

There are some "reverse engineering" outfits of varying quality that offer schematics of just about anything. These folks often will advertise in *Radio-Electronics* and *Nuts and Volts* magazines.

Until recently, *Hewlett-Packard* has been a great source of laser printer repair manuals. Since HP and Apple share the same *Canon* engines, pretty near everything in those HP manuals applies to the similar Apple machines. And Apple manuals are impossibly difficult to latch on to. Besides being poorer than the comparable HP manual in the first place. Details in the [Ask the Guru](#) reprints.

Sadly, HP has recently tripled the price of their laser printer manuals up into the hundred dollar range. You know how it goes when you sell lots of something. You have to add shifts and hire new people for the shipping room. And there's all those extra annual reports to print up. After all, those new employees have to be paid.

Be sure to check all the possible sources of a competitive product for service and repair info. Chances are that one source is a lot looser than most.

To me, it is monumentally stupid not to fully publish your schematics, service information, or ROM listings. Or, for that matter, making your source code listings available at reasonable cost. Failing to do this has caused Apple to go downhill ever since the original red book. Lack of Mac schematics and service info is just plain dumb.

### Networking

Networking is simply asking others for help. These can be real people in the case of community college courses, work associates, ham radio clubs, computer user groups, or technical hotlines.

Or you can go the electronic BBS route. There are many tens of thousands of electronic bulletin boards up today. With general or special interests that apply to just about anything or anyone. These are by far the fastest and the cheapest way of linking yourself up with experts in just

about any field, technical or otherwise.

There are four electronic boards which are head and shoulders above the rest. The first two of these are *GENie* (800) 638-9636 and *CompuServe* at (800) 848-8199. *GENie* alone has nearly 125,000 files and programs available for your immediate downloading at costs averaging around twenty one cents each.

Besides my very own PSRT RoundTable on *GENie*, other RoundTables here that you will find of more than passing interest do include *MAC*, *IBM*, *RADIO* (incredibly great technical downloads), *HOSB* (for home office and small business) and *DTP* (for desktop publishing). There are, of course many hundreds more.

The third truly great BBS is *The Well* at (415) 332-4355. This online Whole Earth service is very heavy in the areas of alternate energy and small-is-beautiful topics.

The Well people also publish the *Whole Earth Review*, a magazine I do find indispensable for serious research on working tools and source of supply. These are the *Whole Earth Catalog* folks at the same old stall after all these years. Uniquely doing what they do best.

And finally there is *UseNet*, the greatest piracy cove in the known universe. The time from when someone decides to keep some code a secret till the greatly improved version appears on *UseNet* is usually measured in nanoseconds. In several cases, the response time clearly has exceeded the speed of light. For free *UseNet* access, you'll have to ask around at your local university.

The UNIX-based *UseNet* is also known as *Anarchy 101* among its denizens. Strange but useful folks fer sure.

### Consultant Referrals

I'm in the process of more or less legitimizing our highly informal *consultant's network* that has grown up around my no-charge technical helpline. There's now a stable of some several hundred *Midnight Engineers* who, for a reasonable fee, can solve problems for you.

Fields currently covered include electronics, publishing, kits, PostScript, cable tv, vacuum technology, chemistry, programming, electronic speech, video, mechanical design, and agricultural stuff. Plus, of course, *tinaja questing*.

There is no charge for referral to one or more of these consultants. The consultants themselves are expected to pay a five percent finder's fee when work is completed.

If you need a *Midnight Engineering* consultant, just give me a call on the helpline below. Should you wish to join my *Synergetics* consultant's net, just prove to me who you are and why you deserve to be on the list. ♦

UPDATE: I left this pretty much as it was for historical accuracy. *GENie* is gone. *Oxbridge* is cheaper than *Ulrich's*. See [www.tinaja.com](http://www.tinaja.com) for newer web-based research tools.

*Microcomputer pioneer and guru Don Lancaster is the author of 35 books and countless articles. Don maintains a US technical helpline you'll find at (520) 428-4073, besides offering all his own books, reprints and consulting services.*

*Don has a free new catalog crammed full of his latest insider secrets waiting for you. Your best calling times are 8-5 weekdays, Mountain Standard Time.*

*Don is also the webmaster of [www.tinaja.com](http://www.tinaja.com) You can also reach Don at Synergetics, Box 809, Thatcher, AZ 85552. Or you can use email via [don@tinaja.com](mailto:don@tinaja.com)*

### PLEASE CLICK HERE TO...



Get a **Synergetics catalog**



Start your **tech venture**



Sponsor a **display banner**



Find **research solutions**



Send **Don Lancaster email**



Pick up surplus **bargains**



Find out what a **tinaja is**



View recommended **books**



Don Lancaster's

# RESOURCE BIN

number seventy one

## My secrets of web-based research.

**O**ur usual reminder here that the *Resource Bin* is now a two-way column. You can get tech help, consultant referrals and off-the-wall networking on nearly any electronic, *tinaja questing*, personal publishing, money machine, or computer topic by calling me at (520) 428-4073 weekdays 8-5 Mountain Standard Time.

I'm now in the process of setting up my new *Guru's Lair* web site you will find at (where else?) [www.tinaja.com](http://www.tinaja.com) This is the place you'll go for instant tech answers. Among the many files in our library, you will find complete reprint sets for all of the *Resource Bin* and other columns. Plus a brand new **Research InfoPack Service**.

You will get the best results if you have both *Netscape Communicator* and *Acrobat Reader 3.0* installed.

### Web Research Secrets

I sure do get a lot of helpline calls asking about the basic tools you will need to locate stuff on the web. So, I thought we might once again review just where you can go to instantly get stuff electronically...

### Search Engines

A *search engine* is a good starting point to find anything on the web. My favorite search engine is the *Hotbot* you'll find at [www.hotbot.com](http://www.hotbot.com). Besides the usual searches for exact phrases or "any" and "all" words, this site also lets you find people and even links to your own website.

The latter sure is a great ego trip. Finding out who knows about you is one useful way to see how well your web promotion efforts are working. Url links are also a means to find out what others think about a site.

Or to find related sites on a linked list third party collection.

Another popular search engine is *Alta Vista* at [www.altavista.digital.com](http://www.altavista.digital.com).

This one appears to find almost as

much as Hotbot almost as well. But Hotbot lets me view more results at once. And lets you restrict by date. The "find url" feature on Alta Vista is somewhat hidden. You have to prefix your search with *link*.

As in *link:www.tinaja.com*

A hint: To find an exact phrase or a name, put the words in quotes. This will miss a lot and give you less hits.

But can be fast and accurate.

Some seventy or so of the popular search engines are gathered together at [www.wp.com/resch/search.htm](http://www.wp.com/resch/search.htm). One brand new *inference* engine is offered at [www.inference.com/infind](http://www.inference.com/infind). This one does not appear to be able to find all that much, but it sure arranges what it is able to find very nicely.

### Ezines, Newsgroups, and Newsletters

These are all special interest online publications, each having their own strengths and weaknesses.

An *ezone* could be any electronically published magazine. Some have print companions; others do not. Examples of my own ezines include the *Blatant Opportunist*, *Tech Musings*, *Guru's Lair*, *Resource Bin*, and *Hardware Hacker*.

All on [www.tinaja.com](http://www.tinaja.com).

The best ezine directory seems to be John Labovitz's [www.meer.net/~john/e-zine-list](http://www.meer.net/~john/e-zine-list) Some other useful locators

**NEXT MONTH: Don looks into new microwave and wireless developments.**

are found at [www.dominis.com/Zines](http://www.dominis.com/Zines) or [www.edoc.com/ejournal](http://www.edoc.com/ejournal)

My favorite printed zine and web ezine commentary is Seth Friedman's *Factsheet Five* at [www.well.com/conf/f5/f5index2.html](http://www.well.com/conf/f5/f5index2.html) There's something here to offend everyone.

A *NewsGroup* is a Usenet forum to

which anyone can post and anyone can subscribe. There are many tens of thousands of these which target most any imaginable special interest topic. The nice thing about newsgroups is that you might visit these only when and where you want, actually reading only those threads and the authors of current interest to you.

The bad thing about newsgroups is that their quality can get really poor. Many newsgroups are not moderated, so anyone can say anything. There's a lot of naive and misinformed posting here, scads of hidden agendas, plus great heaping bunches of investive insults. So much so that all the real experts in most fields won't put up with such time wasting nonsense.

And are promptly driven away.

Newsgroups are also the home of *trolls*. A troll is an life-challenged and clue-challenged individual who posts in such a tone as to totally infuriate the other users into making irrational responses. Troll skill levels can range from immature juvenile newbies to diabolical fiends. Your surest way to spot any troll is whenever they flame *themselves* on slow days. Some even conjure carefully crafted *Sock Puppet* alter egos. Needless to say, you *never* respond to any troll in any manner. Ignore them and they'll go away.

Or else Bozo filter them.

You can access these newsgroups through the *news server* at your local ISP. Most include news access in their basic rate; others will charge a little extra. The news service will include a listing and a search service.

The usual starting point to find out all about newsgroups is *Deja News* at [www.dejanews.com/home\\_ps.shtml](http://www.dejanews.com/home_ps.shtml) This one also lets you scope out those *other* groups a given responder is posting to. Thus, you're able to quickly run a credibility and background check. But I like the *Usenet* search feature of *Alta Vista* better. It finds more stuff.

I've put a hot linked newsgroup list to [www.tinaja.com/text/newslist.html](http://www.tinaja.com/text/newslist.html)

"FAQ" is short for *Frequently Asked Questions*. Better newsgroups do try to answer all of the obvious queries that newcomers ask in downloadable files. A master directory for the FAQ sites appears as [www.faqlib.com](http://www.faqlib.com)

Three newsgroup rules: *Always lurk before you post*. Preferably for several weeks. Always carefully read *all* the other responses before posting. And *never* post anything to a newsgroup without *at least* a 24 hour delay for thinking out your message.

A *newsletter* (or *mailing list*) can be thought of as a "subscription only" newsgroup. The postings are usually moderated, thoroughly stomping all the garbage, the flames, and the trolls. The people here are usually far more knowledgeable, infinitely more polite, and the content quality is often much higher. Membership might be strictly limited, and charges may apply.

You've got a choice of receiving dozens (and possibly hundreds) of email newsletter messages daily. Or of receiving a few humongous and hard to search *digest* files. Either way, newsgroups could provide you with useful information and contacts. But normally do so in an annoying and obnoxiously intrusive way.

Newsgroups are tightly targeted. Email [Vanagon@gerry.sdsc.edu](mailto:Vanagon@gerry.sdsc.edu) with a message of *subscribe vanagon* or else *subscribe vanagon digest*, and you'll be placed on their fine mailing list for a newsletter on 1987 Synchro 4WD vans with diff locks.

You subscribe to other newsgroups in pretty much the same manner. By emailing them your requests. *PAML* is one newsletter directory service.

At [www.NeoSoft.com/Internet/paml](http://www.NeoSoft.com/Internet/paml)

### Finding People

Online phone directories are your obvious place to start people finding. These do include *Lookup USA* at, of all places, [www.lookupusa.com](http://www.lookupusa.com); competitor *Switchboard* at [www.switchboard.com/cg/qa.dll?MG=](http://www.switchboard.com/cg/qa.dll?MG=); and the Ma Bell toll free 800 number directory [attnet/dir800](http://attnet/dir800).

*Lookup USA* also can provide maps. A second useful map site is *Mapquest* at [www.mapquest.com](http://www.mapquest.com)

If the individual is active online, try finding them by way of *WhoWhere* at [www.whowhere.com](http://www.whowhere.com) or else use *Four11* at [www.Four11.com](http://www.Four11.com)

If the person you are looking for is active in newsgroups, *Deja News* is once again a powerful access choice.

### Basic Research Tools

Here is one quick rundown of the research sites on the web that I use most for my own consulting:

*Books in Print* does not seem to be online just yet. But *Amazon Books* at [www.amazon.com](http://www.amazon.com) is a useful alternate that works even better. Similarly, that *Ulrich's Periodicals Dictionary* also does not seem to be available online. Their *Oxbridge Media Finder* competitor is now completely blowing them out of the water at [www.mediafinder.com](http://www.mediafinder.com)

Surprisingly, the complete and free *Thomas Registry of Manufacturers* is now available online at [www.thomasregister.com/index.html](http://www.thomasregister.com/index.html) You do have to register and remember a password. This is a great place to go to find out stuff about old line companies who are not yet web literate.

A great selection of technical books (many involving historical or "lost art") can be located through *Lindsay* at [www.keynet.net/~lindsay/](http://www.keynet.net/~lindsay/) A directory of online published books is available through [www.cs.cmu.edu/books.html](http://www.cs.cmu.edu/books.html)

I've got a whole page of electrical engineering links uploaded for you at [www.tinaja.com/eeweb01.html](http://www.tinaja.com/eeweb01.html) Other superb electronics access can be found at [techweb.cmp.com/eet/docs](http://techweb.cmp.com/eet/docs)

Government surplus electronics are found at [131.87.1.51](http://131.87.1.51), while one leading surplus electronics auction house is *Bentley* at [www.bentleysauction.com](http://www.bentleysauction.com).

Other surplus bargains can often be gotten at [www.tinaja.com/barg01.html](http://www.tinaja.com/barg01.html)

A USPS zip code directory can be found at [www.usps.gov/ncsc](http://www.usps.gov/ncsc) A great periodical table of the elements is at [www2.shef.ac.uk/~chem/web-elements](http://www2.shef.ac.uk/~chem/web-elements)

A fully searchable patent repository resides at the [patent/womplex.ibm.com](http://patent/womplex.ibm.com). But do remember that winners appear in the marketplace and losers appear in the patent directories. More on this in my *Case Against Patents* package or at [www.tinaja.com/patnt01.html](http://www.tinaja.com/patnt01.html).

You can find the darndest stuff on the web if you dig deep enough. For instance, you can track Arizona floods real time with the live stream gauge satellite monitors at [www.daztcn.wr.usg.gov/rt-cgi/gen\\_tbl\\_pg](http://www.daztcn.wr.usg.gov/rt-cgi/gen_tbl_pg)

Betcha you don't already have this one bookmarked.

### Investments, Medicine, Jobs, and Movies

Let's quickly look at a few of my favorite nontechnical sites. The best investment links I've found are the superb *Wall Street Research Network* at

## new from DON LANCASTER

### ACTIVE FILTER COOKBOOK

The sixteenth (!) printing of Don's bible on analog op-amp lowpass, bandpass, and highpass active filters. De-mystified instant designs. **\$28.50**

### CMOS AND TTL COOKBOOKS

Millions of copies in print worldwide. THE two books for digital integrated circuit fundamentals. About as hands-on as you can get. **\$28.50** each.

### RESEARCH INFOPACKS

Don's instant cash-and-carry flat rate consulting service. Ask any reasonable technical question for a detailed analysis and complete report. See [www.tinaja.com/info01](http://www.tinaja.com/info01) for specifics. **\$75.00**

### INCREDIBLE SECRET MONEY MACHINE II

Updated 2nd edition of Don's classic on setting up your own technical or craft venture. **\$18.50**

### LANCASTER CLASSICS LIBRARY

Don's best early stuff at a bargain price. Includes the CMOS Cookbook, The TTL Cookbook, Active Filter Cookbook, PostScript video, Case Against Patents, Incredible Secret Money Machine II, and Hardware Hacker II reprints. **\$119.50**

### LOTS OF OTHER GOODIES

Tech Musings V or VI	\$24.50
Ask the Guru I or II or III	\$24.50
Hardware Hacker II, III or IV	\$24.50
Micro Cookbook I	\$19.50
PostScript Beginner Stuff	\$29.50
PostScript Show and Tell	\$29.50
Intro to PostScript Video	\$29.50
PostScript Reference II	\$34.50
PostScript Tutorial/Cookbook	\$22.50
PostScript by Example	\$32.50
Understanding PS Programming	\$29.50
PostScript: A Visual Approach	\$22.50
PostScript Program Design	\$24.50
Thinking in PostScript	\$22.50
LaserWriter Reference	\$19.50
Type 1 Font Format	\$16.50
Acrobat Reference	\$24.50
Whole works (all PostScript)	\$380.00
Technical Insider Secrets	FREE

### BOOK-ON-DEMAND PUB KIT

Ongoing details on Book-on-demand publishing, a new method of producing books only when and as ordered. Reprints, sources, samples. **\$39.50**

### THE CASE AGAINST PATENTS

For most individuals, patents are virtually certain to result in a net loss of sanity, energy, time, and money. This reprint set shows you Don's tested and proven real-world alternatives. **28.50**

### BLATANT OPPORTUNIST I

The reprints from all Don's Midnight Engineering columns. Includes a broad range of real world, proven coverage on small scale technical startup ventures. Stuff you can use right now. **\$24.50**

### RESOURCE BIN I

A complete collection of all Don's Nuts & Volts columns to date, including a new index and his master names and numbers list. **\$24.50**

### FREE SAMPLES

Check Don's Guru's Lair at <http://www.tinaja.com> for interactive catalogs and online samples of Don's unique products. Searchable reprints and reference resources, too. Tech help, hot links to cool sites, consultants. email: [don@tinaja.com](mailto:don@tinaja.com)

FREE US VOICE HELPLINE VISA/MC

**SYNERGETICS**  
Box 809-NV  
Thatcher, AZ 85552  
(520) 428-4073

FREE Catalog: <http://www.tinaja.com>

## A FEW USEFUL WEB RESEARCH SITES

Acrobat newsgroup	<a href="#">comp.text.pdf</a>
Adobe Acrobat Reader	<a href="#">www.adobe.com/prodindex/acrobat/readstep.html</a>
Alta Vista search engine	<a href="#">www.altavista.digital.com</a>
Alternate ezine directory	<a href="#">www.dominis.com/Zines</a>
Alternate ezine directory	<a href="#">www.edoc.com/ejournal</a>
Basic Stamp support	<a href="#">www.parallaxinc.com</a>
Bed and breakfast directory	<a href="#">www.homearts.com/affil/ahi/main/ahihome.htm</a>
Best book info	<a href="#">www.amazon.com</a>
Best ezine directory	<a href="#">www.meer.net/~johnl/e-zine-list</a>
Bizarre Pseudoscience	<a href="#">www.tinaja.com/scweb01.html</a>
Black Range Lodge	<a href="#">www.zianet.com/blackrange/lodge.html</a>
Blond Aggie redneck lawyers	<a href="#">www.winn.com/pwinn/humor/index/html</a>
Car trader	<a href="#">www.traderonline.com</a>
Cattle Moo Tillations	<a href="#">www.qtm.net/~geibdan/framest.html</a>
Church of the SubGenius	<a href="#">sunsite/unc.edu/subgenius</a>
Classified shopper	<a href="#">www.classifieds2000.com</a>
Dilbert and Dogbert	<a href="#">www.unitedmedia.com/comics/dilbert</a>
Don Lancaster's Guru's Lair	<a href="#">www.tinaja.com</a>
Emory University MedWeb	<a href="#">www.gen.emory.edu/medweb</a>
Factsheet Five on zines	<a href="#">www.well.com/conf/f5/f5index2.html</a>
FM radio station finder	<a href="#">wmbr.mit.edu/stations/locate.html</a>
Four11 phone finder	<a href="#">www.Four11.com</a>
Free catalogs	<a href="#">catalog.savvy.com</a>
Free energy forum	<a href="#">www.eskimo.com/~bilb/freenrg/frng</a>
Free Medline medical info	<a href="#">www.healthy.net</a>
Electronic auctions	<a href="#">www.bentleysauction.com</a>
Electronic engineer links	<a href="#">www.tinaja.com/eeweb01.html</a>
Hotbot search engine	<a href="#">www.hotbot.com</a>
Inference search engine	<a href="#">www.inference.com/infind</a>
InfoPack research services	<a href="#">www.tinaja.com/info01.html</a>
Interesting site links	<a href="#">www.persiankitty.com</a>
Internet country codes	<a href="#">www.Four11.com/cgi-bin/Four11Main?Country</a>
Internet Service Providers	<a href="#">thelist.iworld.com</a>
Jerry Decker's Keelynet	<a href="#">www.keelynet.com</a>
Job listing links	<a href="#">www.datamation.com/Plugin/jobs/jobs.html</a>
Kelly Blue Book	<a href="#">www.kbb.com</a>
Lindsay Publications	<a href="#">www.keynet.net/~lindsay</a>
Lookup USA phone directory	<a href="#">www.lookupusa.com</a>
Ma Bell 800 numbers	<a href="#">attnet/dir800</a>
Mapquest map drawing site	<a href="#">www.mapquest.com</a>
Master FAQ directory	<a href="#">www.faqlib.com</a>
Master PIC directory	<a href="#">www.tinaja.com/pic500</a>
Meta search engine site	<a href="#">www.wp.com/resch/search.htm</a>
Microchip Technology	<a href="#">www.microchip.com</a>
Mo Hotta Mo Betta	<a href="#">www.mohotta.com</a>
More Acrobat support	<a href="#">www.tinaja.com/acrobo1.html</a>
Movie reviews & info	<a href="#">us.imdb.com</a>
Online published books	<a href="#">www.cs.cmu.edu/books.html</a>
Oxbridge Media Finder	<a href="#">www.mediafinder.com</a>
PAML newsletter directory	<a href="#">www.NeoSoft.com/Internet/pami</a>
Patent repository	<a href="#">patent/womplex.ibm.com</a>
Periodical elements table	<a href="#">www2.shef.ac.uk/~chem?web-elements</a>
PIC reprints & support	<a href="#">www.tinaja.com/picup01.html</a>
Random cyberspace jump	<a href="#">www.yahoo.com/bin/top2?122.25</a>
Real time Arizona floods	<a href="#">www.daztcn.wr.usgs.gov/rt-cgi/gen_tbl_pg</a>
Saucer Smear magazine	<a href="#">www.mcs.com/~kvg/smear.htm</a>
Scott Edwards	<a href="#">www.seetron.com</a>
Science Hobbyist	<a href="#">www.eskimo.com/~billb</a>
Shepard Engineering	<a href="#">home.att.net/~dennis.shepard</a>
Surplus bargains	<a href="#">www.tinaja.com/barg01.html</a>
Switchboard phone directory	<a href="#">www.switchboard.com/cgiqa.dll?MG=</a>
Technical electronics	<a href="#">techweb.cmp.com/eet/docs</a>
US Government surplus	<a href="#">131.87.1.51</a>
USPS zip code directory	<a href="#">www.usps.gov/ncsc</a>
Volkswagen Van newsletter	<a href="#">Vanagon@gerry.sdsc.edu</a>
Wall Street investment net	<a href="#">wsrn.com</a>
Web site free promotion	<a href="#">www2com.com/~upfront/launch</a>
Web site free promotion	<a href="#">www.ep.com/faq/webannounce.html</a>
Web site name finder	<a href="#">www.internic.net/cgi-bin/whois</a>
Web site registration	<a href="#">www.internic.net</a>
Webmastering secrets	<a href="#">www.tiaja.com/weblib01.html</a>
WhoWhere people finder	<a href="#">www.whowhere.com</a>

[wsrn.com](#).

The place doctors go to get info is the fee based *Medline* service. One free medline link is [www.healthy.net](#)

Another very useful medical link is [www.gen.emory.edu/medweb](#)

One extensive job listing source is [www.datamation.com/plugin/jobs](#)

A leading movie review site is the *Internet Movie Database* at [us.imdb.com](#)

Places to buy and sell stuff include [www.classifieds2000.com](#) and the *Trader Online* people at [www.traderonline.com](#)  
Car appraisal is best done through the *Kelly Blue Book* at [www.kbb.com](#)

Thousands of free catalogs are now offered by [catalog.savvy.com](#)

Essential hacker nutrients are at *Mo Hotta Mo Betta* ([www.mohotta.com](#))  
One good bed and breakfast directory is [www.homearts.com/affil/ahi/main/ahi/home.htm](#) while our favorite B&B is the *Black Range Lodge* at [www.zianet.com/blackrange/lodge.html](#)

A really great FM station finder is at [wmbr.mit.edu/stations/locate.html](#)

Check this one out.

### Adobe Acrobat

Typical web technical information (especially electronic data sheets) is now presented in *Adobe Acrobat* or .PDF format. In *one* fast-loading single file, Acrobat can give you a "perfect" camera ready image, having exactly and only what your provider wishes you to see in precisely the way they want you to see it. With all fonts and artwork and images and text fully and perfectly preserved. Magnifiable, and with text smoothing, even.

If you know the secret insider trick, Acrobat gives you instant online and hot linked *full screen* displays. Just click on your PDF selection and let it autoloading into Netscape. Then enter ctrl-shift-L followed by ctrl-K. Presto. Your full screen "just like the printed page" display. Easily navigated with the usual keys or mouse moves. And printable on any newer printer.

A hint: Set your Acrobat full screen preferences to activate escape, apply vertical wipe, set cursor hidden after delay, and use loop wraparound. But unclick your auto advance.

You can get the latest free Acrobat 3.01 reader from [www.adobe.com/prodindex/acrobat/readstep.html](#) Always do install Netscape first and Acrobat 3.01 second, so your plug ins get properly placed into your browser.

There's an acrobat newsgroup at [comp.text.pdf](#) and more Acrobat info at [www.tinaja.com/acrobo1.html](#)



## Web Related

Your usual place to go to register your personal website is Internic at [www.internic.net](http://www.internic.net). They also have their whois at [www.internic.net/cgi-bin/whois](http://www.internic.net/cgi-bin/whois) that lets you find if a domain name is in use and who owns it.

Useful locations to promote your website at no charge now do include [www2com.com/~upfront/launch](http://www2com.com/~upfront/launch) plus [www.ep.com/faq/webannounce.html](http://www.ep.com/faq/webannounce.html). A handy listing for the internet country codes appears at [www.Four11.com/cgi-bin/Four11Main?Country](http://www.Four11.com/cgi-bin/Four11Main?Country), while the master directory of ISP *Internet Service Providers* is at [thelist.iworld.com](http://thelist.iworld.com)

A few more webmastering access tools: [www.tinaja.com/webwb01.html](http://www.tinaja.com/webwb01.html)

## PIC Related

The horse's whatever on PIC info is *Microchip* at [www.microchip.com](http://www.microchip.com). Other great PIC sites include the *Basic Stamp* people at [www.parallaxinc.com](http://www.parallaxinc.com), *Shepard Engineering* at [home.att.net/~dennis.shepard](http://home.att.net/~dennis.shepard), or the Scott Edwards Electronics at [www.seetron.com](http://www.seetron.com)

A master directory of PIC websites is at [www.tinaja.com/pic500](http://www.tinaja.com/pic500), while PIC reprints and other useful content are found both at my [picup01.html](http://picup01.html) and at [picwb01.html](http://picwb01.html) on the same site.

## Pseudoscience

One of my very favorite activities is pseudoscience bashing. Besides being mesmerizingly awful fiction, this can give me unique directions to present fundamental electronic, chemical and physical principles.

I also have this goal of piling up all of pseudoscience in the middle of a big stage somewhere, shining a bright light on it, and getting all of you to conclude "Yup - That sure is a really big pile alright".

Only tiny problem is that a lot of it keeps leaking out of the bottom.

My favorite source for this sort of thing is [www.keelynet.com](http://www.keelynet.com)

Bill Beatty runs his superb *Science Hobbyist* site at [www.eskimo.com/~billb](http://www.eskimo.com/~billb)

which combines both real science and pseudoscience file downloads. He also hosts a bizarre free energy forum at [www.eskimo.com/~bilb/freenrg/frng](http://www.eskimo.com/~bilb/freenrg/frng). But watch out for all the "not even wrong" labwork here.

And, of course, Mosley's old *Saucer Smear* at [www.mcs.com/~kvg/smear.htm](http://www.mcs.com/~kvg/smear.htm) uses "in your face" journalism to slam UFO friend and foe alike.

Now in their 43rd year!

Cattle *Moo Tillations* are covered by [www.qtm.net/~geibdan/framest.html](http://www.qtm.net/~geibdan/framest.html) Lots more pseudoscience site links are at [www.tinaja.com/scweb01.html](http://www.tinaja.com/scweb01.html)

## Just For Fun

Those Guru's and Swami's Union local #204 rules do demand that all technical internet sites have a Dilbert and Dogbert link. You'll find them at [www.unitedmedia.com/comics/dilbert](http://www.unitedmedia.com/comics/dilbert). To pick up all of the latest blond Aggie redneck lower jokes, try [www.winn.com/pwinn/humor/index/html](http://www.winn.com/pwinn/humor/index/html). I really do like the one here where Wiley Coyote is filing a product liability suit against *Acme* manufacturing.

An interesting variety of site links is offered by [www.persiankitty.com](http://www.persiankitty.com)

If you want to go completely off the planet in your web explorations, do check out the *Church of the SubGenius* at [sunsite/unc.edu/subgenius](http://sunsite/unc.edu/subgenius)

One ultimate for-fun venture is to make a random jump somewhere in cyberspace and see where you land. One good way to do this is by using [www.yahoo.com/bin/top2?122.25](http://www.yahoo.com/bin/top2?122.25) Since this link is now "hidden" by its host, it might not stay around forever.

## For More Help

The best way to find things on the web is to jump in with both feet and start doing it. If you do not yet have a web account with the local ISP, try borrowing a friend's internet access. Or go to your local library to begin picking up experience. Or sign up for a community college course.

*Hands on is everything!*

Hot links to all of these mentioned

research tools appear on my *Guru's Lair* website at [www.tinaja.com](http://www.tinaja.com). Start with all of those *Web Related Links* at [www.tinaja.com/webwb01.html](http://www.tinaja.com/webwb01.html) Then try those seven other link buttons.

Additional insider web tricks and techniques in the *Webmaster Library* at [www.tinaja.com/weblib01.html](http://www.tinaja.com/weblib01.html) The hot linked version of this column is up at <http://www.tinaja.com/glib/resbn71.pdf> Just click on any blue text to instantly go anywhere mentioned. By using Acrobat's online full screen feature.

Finally, if you don't want to do your own web research, I'd be most happy to do most of it for you. Full details all about my unique *InfoPack* consulting service can now be found at [www.tinaja.com/info01.html](http://www.tinaja.com/info01.html)

## This Month's Contest

For our contest this month, just tell me about any useful and unusual web site I don't already know about. Tell me what it does. And why you like it.

There should be a largish pile of my new *Incredible Secret Money Machine II* books going to the dozen or so better entries, plus an all-expense-paid (FOB Thatcher, AZ) *tinaja quest* for two that will go to the very best of all.

Send all your *written* entries to me here at *Synergetics*, rather than to *Nuts & Volts* editorial. ♦

---

*Microcomputer pioneer and guru Don Lancaster is the author of 33 books and countless tech articles. Don maintains his no-charge US tech helpline found at (520) 428-4073, besides offering all of his own books, reprints, and consulting services. Don also offers a free catalog full of his unique products and resource secrets. The best calling times are 8-5 on weekdays, Mountain Standard Time.*

*Don is in the process of setting up his Guru's Lair at <http://www.tinaja.com>*

*Full reprints and preprints of all Don's columns and ongoing tech support appear here. You can reach Don at Synergetics, Box 809, Thatcher, AZ 85552. Or send any messages to his US Internet address of [don@tinaja.com](mailto:don@tinaja.com)*

Don Lancaster's

# RESOURCE BIN

number thirty

## Conducting your own personal research.

**O**ur usual reminder here that the *Resource Bin* is now a two-way column. You can get tech help, consultant referrals and off-the-wall networking on nearly any electronic, *tinaja questing*, personal publishing, money machine, or computer topic by calling me at (520) 428-4073 weekdays 8-5 Mountain Standard Time.

A portion of my PSRT RoundTable on *GENie* has also been set aside for you *Nuts & Volts* readers. This is the place you go for instant tech answers. Among the many files in our library, you will find complete reprints and preprints for all of my *Resource Bin* columns. For quick access, just have your modem dial (800) 638-8369, and type HHH. On the password prompt, enter JOINGENIE. On the keyword prompt, enter DMD524.

I did manage to wrangle a super special signup deal for you *Resource Bin* readers. Ten free hours and zero first month minimums.

By the way, be sure to enter your HHH *immediately* after your modem software reports a connection. This is how *GENie* recognizes your baud rate. If you get gibberish on the screen, you were too slow with your HHH.

I've also now got a brand new free catalog for you that includes a greatly expanded insider secrets section. Call or write for your copy. Or grab it off PSRT as SYNCAT1.PS. You can also get it via the Internet.

### Self-Directed Research

I sure do get lots of calls and letters from you *Nuts & Volts* readers asking technical questions. After a while, it gets obvious that at least some of you don't have the foggiest notion what personal research is all about.

Some claim that they have "looked everywhere" and were totally unable to find anything at all on their subject topic. Or complain about how hard it is to do things in a "remote" area.

Well, their ain't no "remote" no mo, no mo. No way. No how.

Thanks to the magic of any decent modem installed with your personal computer, you can easily do first rate, world-class research from anywhere you want to. Instantly. At any time of day or night. On, beneath, or above ground. So, this month, I thought we might review the main tools needed to find answers to *any* question or the solutions to *any* problem.

### The Electronic Hobby Press

*Nuts & Volts* is obviously a good choice here, but there certainly are a few other good ones. The highest tech pub and the one having the longest history is *Electronics Now*. Traceable clear back to Hugo Gernsback's *Radio World* from the early 1900's.

They also print *Popular Electronics*. While a fine magazine, this is clearly *not* the original PE of Carl and Jerry fame. The original one got Ziffed out of existence long ago.

Probably your finest source for computer-oriented projects is Steve Ciracia's *Circuit Cellar Ink*. Plenty of solidly designed and supported kits here. Another magazine now coming

**NEXT MONTH: Don looks at emerging opportunities in laser publishing.**

on strong is *Home Power*. A quality labor-of-love publication by Richard and Kathy Perez.

For the business aspects of running your own small tech venture, there's *Midnight Engineering*. And the best foreign electronics magazine is still Britian's *Wireless World*.

One important rule: Be sure you go back far enough! The golden age of electronic hobby kits lasted from 1966 to 1973. Incredible products appeared

in this era. Really great stuff.

I have found most of the ultra-slick computer magazines to be less than useless. These are all overwhelmingly advertiser driven. They rarely show you how to accomplish anything on the cheap. One big exception is Jeff Duntemann's *PC Techniques*. About the only one that values their readers highly enough to give them bunches of really useful material.

Of the computer news magazines, I subscribe to *InfoWorld*, and *MacWeek*. There is also a *PCWeek* for PC users. I find the daily technology page of the *Wall Street Journal* to be useful.

### Trade Journals

It still amazes me how many people never heard of the trade journals. Yet, these remain your first and foremost route to becoming literate in most any technical area. There's over 150,000 *different* magazines and trade journals worldwide. Many of these are free to "qualified" subscribers.

Of the electronic trade journals, the most important four are *E.E. Times*, *Electronic Design*, *EDN*, and *Electronic Component News*. A complete list is shown in NUTS8.PS on *GENie* PSRT.

In *any* field, your first and foremost pry bar into any tech area lies in using the trade journals. From the journals, you use the bingo cards to get data books, ap notes, directories, and trade shows. The trade journals are useful to show you what is important and what is not. As well as showing you the mainstream ways of doing things.

Or the latest industry trends.

The best listings appear in *Ulricht's Periodicals Distionary*. You should find *Ulricht's* on your library's reference shelf, as well as being offered on-line by many services.

The *Standard Periodical's Dictionary* is a close second. And one that does not quite overlap.

One trick: Ask any trade journal

that carries ads for a *media kit* or else a *Sample Copy and Ad Rates*. I call this my SCAR technique. Sometimes it gets you a freebie sub. At the least, it gets you a recent copy. For the price of a phone call or stamp.

### Other Library Stuff

There's lots more available in the way of traditional library references. These are also fast becoming available on-line in one form or another.

For instance, there's the *Encyclopedia of Associations*. And the real ancient *Thomas Registry of Manufacturers* that shows you who makes what. But rarely has any up-to-date and useful stuff on smaller hi-tech firms.

My favorite obscure reference work is the *Science Citation Index*. This is the only source I know of which lets you continually find *newer* material!

Here is how it works: Every time someone references somebody else in their bibliography, it ends up in this directory. For instance, *the horse's* mouth paper on active filters is *Sallen and Key*. Anything newer in the field *must* reference this paper or its own credibility will be sorely lacking. Just chase their names forward through time. Then use the *avalanche effect* on repeat quotes from later authors and researchers. *Forward* through time!

The leading publishers for library reference research material are *Gale Research*, *Bowker*, and *Oxbridge*.

Libraries are starting to go to CD ROM "jukebox" data bases. You can easily do fancy referencing and apply keywords six ways from Sunday.

### On-line Resources

To me, it does seem foolish to run around to libraries only to find they do not have what you need.

Virtually *all* serious research these days can get done on-line by modem. The libraries themselves are on to this, so most of them now offer their own free local BBS service. At the least, a complete card catalog is included in their menu selections.

Library BBS numbers are not often advertised. You may have to call the library and ask them for info on their BBS access numbers and rules.

As far as *any* serious research goes, today's on-line services are *by far* your most important resource.

The real big one, of course, is the Internet. Now twenty million users and growing. Sources of info and support on virtually any subject. The easiest method to pick up Internet

access is by way of a commercial BBS. Most of them are now scrambling to greatly expand their Internet services.

Of the major commercial services, *CompuServe* is the largest and *America On Line* is the friendliest. But my own preference is *Genie*.

*Genie* is widely regarded as having the widest selections of tech library downloads. Around 145,000 library files at last count. They also are well regarded for competent and caring sysops. And are the primary board of choice for fiction writers and sci-fi enthusiasts. Among many others.

They are also the lowest priced national BBS at \$3 per hour.

Yes, *Genie* has now upgraded their ancient interfaces, with new Mac and PC versions now available. They also offer ten free trial hours.

There are many tens of thousands of BBS boards up today. Some local; some national. Some are open to all; others members only. Some fee; some free. Many of the larger fee systems have thousands of trunk lines across the country. Fee systems can often be cheaper than distant free ones.

Listings of available BBS systems go out of date faster than they can be printed. You could start with on-line listings on the commercial boards. Or else find *any* local board, and they may list several others.

If you haven't the foggiest how to reach any board in your area, try a local school or computer store.

Of all those BBS services available anywhere ever, one seems head and shoulders above all the others for serious research. This is the...

### Dialog Information Service

Which is the ultimate source for *all* information on *anything*. There are hundreds of commercial information providers who offer fee based on-line research services. Dialog is a broker or a supergroup that handily gathers all of these services together.

Services such as *Inspec*, *Compendex*, *Computer Database*, *SciSearch*, and the *MathSci* for computers, technology, science and electronics. *Conference Papers* holding over 100,000 technical entries. The *Geobase* on geography, geology and ecology. Just about every major newspaper as well.

The same *Medline* medical info that doctors use. Stock quotes in real time. Ten million chem abstracts in *C. A. Search*. And *Dissertation Abstracts* that include *every* thesis of *every* graduate school. Clear on back to 1861.

## new from DON LANCASTER

### ACTIVE FILTER COOKBOOK

The sixteenth (!) printing of Don's bible on analog op-amp lowpass, bandpass, and highpass active filters. De-mystified instant designs. \$24.50

### CMOS AND TTL COOKBOOKS

Millions of copies in print worldwide. THE two books for digital integrated circuit fundamentals. About as hands-on as you can get. \$24.50 each.

### INCREDIBLE SECRET MONEY MACHINE II

Updated 2nd edition of Don's classic on setting up your own technical or craft venture. \$18.50

### LANCASTER CLASSICS LIBRARY

Don's best early stuff at a bargain price. Includes the CMOS Cookbook, The TTL Cookbook, Active Filter Cookbook, PostScript video, Case Against Patents, Incredible Secret Money Machine II, and Hardware Hacker II reprints. \$119.50

### LOTS OF OTHER GOODIES

Ask the Guru I or II or III .....	\$24.50
Hardware Hacker II or III .....	\$24.50
Micro Cookbook I .....	\$19.50
PostScript Beginner Stuff .....	\$29.50
PostScript Show and Tell .....	\$29.50
Intro to PostScript Video .....	\$29.50
PostScript Reference II .....	\$31.50
PostScript Tutorial/Cookbook .....	\$19.50
PostScript by Example .....	\$31.50
Understanding PS Programming .....	\$29.50
PostScript: A Visual Approach .....	\$22.50
PostScript Program Design .....	\$24.50
Thinking in PostScript .....	\$22.50
LaserWriter Reference .....	\$19.50
Type 1 Font Format .....	\$15.50
Acrobat Reference .....	\$24.50
Whole works (all PostScript) .....	\$380.00
PostScript Insider Secrets .....	FREE
Hacking Insider Secrets .....	FREE

### POSTSCRIPT SECRETS

A Book/Disk combination crammed full of free fonts, insider resources, utilities, publications, workarounds, fontgrabbing, more. For most any PostScript printer. Mac or PC format. \$29.50

### BOOK-ON-DEMAND PUB KIT

Ongoing details on Book-on-demand publishing, a new method of producing books only when and as ordered. Reprints, sources, samples. \$39.50

### THE CASE AGAINST PATENTS

For most individuals, patents are virtually certain to result in a net loss of sanity, energy, time, and money. This two volume set shows you tested and proven real-world alternatives. 28.50

### BLATANT OPPORTUNIST I

The reprints from all Don's Midnight Engineering columns. Includes a broad range of real world, proven coverage on small scale technical startup ventures. Stuff you can use right now. \$24.50

### RESOURCE BIN I

A complete collection of all Don's Nuts & Volts columns to date, including a new index and his master names and numbers list. \$24.50

### FREE SAMPLES

Well, nearly free anyway. Almost. Do join us on *Genie* PSRT to sample all of the Guru's goodies. The downloading cost on a typical Guru file is 21 cents. Modem access: (800) 638-8369, then a HHH. On prompt, XTX99005,SCRIPT.

FREE VOICE HELPLINE VISA/MC

**SYNERGETICS**  
Box 809-NV  
Thatcher, AZ 85552  
(520) 428-4073

Write in 146 on Reader Service Card.

## PERSONAL RESEARCH RESOURCES

<b>America On-Line</b> 8619 Westwood Center Dr Vienna VA 22182 (800) 827-6364	<b>Electronic Comp. News</b> 1 Chilton Way Radnor PA 19089 (215) 964-4345	<b>High Energy Enterprises</b> PO Box 5636 Security CO 80931 (719) 475-0918	<b>MIX Bookshelf</b> 6400 Hollis St #12 Emeryville CA 94608 (800) 233-9604	<b>Science Citation Index</b> 3501 Market Street Philadelphia PA 19104 (215) 386-0100
<b>Am. Soc. of Dowders</b> Brainers St Box 24 Danville VT 05828 (802) 881-7165	<b>Electronic Design</b> 611 Rt #46 W Hasbrouck Hgt. NJ 07604 (201) 393-6060	<b>Home Power</b> PO Box 520 Ashland OR 97520 (916) 475-3179	<b>Nuts &amp; Volts</b> 430 Princeland Ct Corona CA 91719 (714) 371-8497	<b>Singing Wind Bookshop</b> Ocotillo Rd Box 2197 Benson AZ 85602 (520) 586-2425
<b>RR Bowker</b> 121 Chanlon Rd New Providence NJ 07974 (908) 464-6800	<b>Electronics Now</b> 500-B Bi-County Blvd Farmingdale NY 11735 (516) 293-3000	<b>InfoWorld</b> 155 Bovet Rd #800 San Mateo CA 94402 (800) 227-8365	<b>Oxbridge</b> 150 5th Ave #202 New York NY 10011 (212) 741-0231	<b>Tesla Book Co</b> Box 121873 Chula Vista CA 91912 (805) 646-3371
<b>CompuServe</b> 5000 Arlington Center Blvd Columbus OH 43220 (800) 848-8199	<b>Encyc. of Associations</b> 835 Penobscot Bldg Detroit MI 48226 (313) 961-2242	<b>Intl Assn New Science</b> 1304 S College Ave Fort Collins CO 80524 (303) 482-3731	<b>PC Techniques</b> 7721 E Gray Rd #204 Scottsdale AZ 85260 (602) 483-0192	<b>Ulrichs Dictionary</b> 121 Chanlon Rd New Providence NJ 07974 (908) 771-7714
<b>Dialog Information Svcs</b> 3460 Hillview Ave Palo Alto CA 94304 (415) 858-2700	<b>Factsheet Five</b> R Seth Friedman PO Box 170099 San Francisco CA 94117	<b>KeelyNet BBS</b> Box 1031 Mesquite TX 75149 (214) 324-3501 BBS	<b>Phaedra Enterprises</b> PO Box 1241 San Bruno CA 94066 (415) 359-0432	<b>UMI</b> 300 N Zeeb Rd Ann Arbor MI 48106 (800) 521-3044
<b>EDN Magazine</b> 275 Washington St Newton MA 02158 (617) 964-3030	<b>Gale Research</b> 835 Penobscot Blvd Detroit MI 48226 (313) 961-2242	<b>MacWeek</b> One Park Ave New York NY 10016 (212) 503-4433	<b>Rex Research</b> Robert Nelson PO Box 19250 Jean NV 89019	<b>Whole Earth Review</b> 27 Gate Five Rd Sausalito CA 94965 (415) 332-1716
<b>EE Times</b> 600 Community Dr Manhassat NY 11030 (516) 365-4600	<b>GENie</b> 401 N Washington St Rockville MD 20850 (800) 638-9636	<b>Midnight Engineering</b> 1700 Washington Ave Rocky Ford CO 81067 (719) 254-4558	<b>SAE Library</b> 400 Commonwealth Dr Warrendale PA 15096 (412) 776-4841	<b>Wireless World</b> The Quadrant, Sutton Surrey, SM2 5AS ENGLAND 01-652-3128

Even the *Foundation Directory* which lists 33,000 organizations which give money away. Employment directories and guides. Business stats.

Dialog offers both a free brochure and directory. To cop this directory, you'll have to pretend like you are going to *directly* subscribe to their big annual service. This directory details hundreds of available data bases.

At first glance, those direct Dialog charges of \$2 per minute might seem steep. Until you factor in that "Uh, compared to what?" of wasting a day or more at a distant library.

Dialog charges are now dropping. With practice, you can easily reduce your charges. Dialog is sometimes available cheaper at some libraries or schools or on company accounts.

Dialog is also offered on CD ROM. Giving you free use of older info. But at a high front end cost.

You can play with Dialog on GENie. Free of any surcharges. They have a special practice area with limited data base coverage. Which is superb for practice or to get the flavor of what serious on-line research is all about. GENie uses a "cash and carry" rate structure. You pay a surcharge by the search and by the abstract. Rather than a flat hourly fee.

A typical search costs \$2.50. I've

found *GENie* cheaper for searching, but my local library is cheaper for the actual abstracting.

### UMI

More often than not, if you simply know a paper exists, you are home free. Other times, the abstract may give you enough extra info.

But sometimes you just gotta have the horse's mouth paper.

One method was *Interlibrary Loan*, once available through most libraries. But this service is slow and unreliable. It is also getting dropped by many libraries as a cost cutting move.

The handiest place to get the actual reprint is at UMI, who used to call themselves *University Microfilms*. Who stock one each of everything.

But UMI is definitely *not* a research service. To order from them, you must know the *exact* journal name, author, volume, and page.

Charges vary with instant, fast, or routine service.

### Patents?

What about patents? Less than one patent in 200 ever shows *any* net positive cash flow. Thus, the majority of patents end up not even remotely useful for anything. I've found patent searches to be a mesmerizingly awful

waste of time. Leading you to what flat out does *not* work or is *not* at all economically viable.

And patenteeze is *guaranteed* to rot your mind. Fer sure.

I have *never* found anything really useful when I've read patents. There are vastly more effective places to do research. Lots of them.

Nonetheless, if you think viewing patents may help your quest, you'll find collections of patents in libraries, on CD ROM, and from Dialog's *Patent Abstracts* data base service.

Much more on all this in my *Case Against Patents* package.

### Alternate Research

Usually, if you cannot find info on your subject, you are not asking the right questions in the right way. Or are not digging deep enough. Or are searching on the wrong *keywords*. The insiders have a lingo of their own. It is super important to find the keywords they use as early as possible.

There are lots of non-traditional research sources. My favorite of these is that quarterly *Whole Earth Review* and their *Whole Earth Catalogs*. Which focus on honestly reviewed tools.

One interesting alternative is that *FactSheet Five*. A review magazine that covers thousands of the labor-of-love

self-published info sources. Mostly on a mind-boggling spectrum of unusual or controversial subjects. These folks have also previously published their *World of 'Zines* volume. There is stuff here guaranteed to offend just about everyone. Truly bizarre.

Most traditional journals shy away from pseudoscience topics. Recently, I was amazed that Dialog had over 8300 references on *solitons*, a legit and an exciting yet obscure new technology. They now do have nearly a full billion references on line. But in all of Dialog, I was only able to find a mere *seven* papers on dowsing.

But digging deep enough into the Encyclopedia of Associations, I did find *American Dowser* magazine.

More on solitons in HACK77.PS and on dowsing in HACK78.PS.

Several outfits target pseudoscience topics. For instance, *Rex Research* now publishes *Infolios* on most any wierd science subject. These are all low cost stapled Xerox reprint collections. And the *KeelyNet* BBS has to be seen to be believed. Everything from perpetual motion to psychic stuff to UFO's.

Speaking of which, your best guide to the UFO industry is the *Almanac of UFO Organizations and Publications* published by *Phaedra*. Fat volumes on perpetual motion are now published by that *International Association for New Science*. One competitor is *High Energy Enterprises*.

### Specialty Bookstores

In any rapidly changing field, the books tend to be highly overrated.

Your primary choice in info sources should be in the on-line services, the trade journals and industry ap notes. Books place a distant fourth.

As you undoubtedly have found out, most bookstores only carry stuff they know sells. Rather than genuine useful books. And library budgets are severely limited these days.

The place to find out if a book exists at all is in *Books in Print*. Either at your local library, a local bookstore, or on line. They also publish the quarterly *Forthcoming Books in Print*.

Your best place to buy books is in a *specialty bookstore*. An organization that stocks *every* title in a narrow field. And tells you which ones do what.

Your foremost source for the older technical and machine shop books has to be *Lindsay Publications*. Who offers a free pair of fascinating catalogs. A few random samples of the specialty bookstores include the *MIX Bookshelf*

on audio and video production, the *Tesla Bookstore*, or the *SAE Library* on automotive subjects.

Here at *Synergetics*, I try to stock the best and most useful of the PostScript books and videos by all authors. If I don't like it, I don't carry it.

My favorite specialty bookstore is the world-class *Singing Wind*, who do focus on southwestern literature and history. This is the only bookstore I know of with an unlisted address. To visit them, you may have to walk on through a pasture of Brahma bulls.

Well, maybe one hint. Just follow Ocotillo Road north out of Benson, Arizona till it feels about right. Then hang right just past the fourth cow.

Don't wear red.

### Insider Helplines

A number of outfits offer technical helplines for one reason or another. These may not be advertised. So ask for "tech assistance" or "applications engineering" when you call.

I offer a tech helpline at no added charge over your phone expenses. We also have a *Synergetics Consultant's Network* in which you can be referred to service providers.

Give me a call if you need info on these. US calls only, please.

Others offer developer programs. I am personally a developer for Adobe, Apple, H-P, and a few others. These can offer you insider tech info, loaner machines, and product discounts.

Some are free. Some are bargains. Others are way overpriced. But most are certainly worth the time and effort to pursue them.

Local and national user groups are another worthwhile source. Again, you get contacts, discounts, and tech expertise at low cost. You also get the straight story from real product users. Warts and all. Good and bad.

Many years ago, my students and I started up a "just barely real" user group we called the *Gila Valley Apple Grower's Association*. We didn't have any dues or meetings or publications or anything like that. But everybody definitely knew whether they were a member or not. Officer selection was by dictatorial edict. Over the years, we have received all sorts of wildly wonderful benefits. Demos, tech info, discounts, videos, conference invites, and bunches more. Not the least was the VIP treatment Steve Wozniak gave us at the first *US Festival*. Which was California's answer to Woodstock.

Personal networking can be super

important. It pays to generate a list of contacts you can call. Contacts who either can give you your answer. Or know someone who does.

### Hands on is Everything

No matter what your source, the finest and best research will end up as any you can personally verify. Just do not get in over your head and keep any bias out of your way.

With any circuit diagram or most software routines, it is *essential* that you step into the lab and check things out. By yourself.

More often than not, there will be hidden gotchas which will nail you every time. Should you blindly use or pass on info without verification.

Besides, your own research can often be the most fun of all. And the most rewarding.

### This Month's Contest

For our contest this month, just tell me about an unusual resource you have found helpful for doing all your own research. Or about your worst personal research fiasco.

Such as the time I found out that thermoelectric coolers simply do not work. They *heat*, rather than cool! Because of heatsink temperatures.

There will be a largish pile of my new *Incredible Secret Money Machine II* books going to the dozen or so better entries, plus an all-expense-paid (FOB Thatcher, AZ) *tinaja quest* for two that will go to the very best of all.

For lots more on doing your own personal research, see my *Resource Bin* and *Blatant Opportunist* reprints, the hundreds of files on *GENie* PSRT. ♦

---

*Microcomputer pioneer and guru Don Lancaster is the author of 32 books and countless tech articles. Don maintains his no-charge tech helpline found at (520) 428-4073, besides offering all of his own books, reprints, and all of his consulting services. He also has a free catalog full of his resource secrets waiting for you. Your best calling times are 8-5 on weekdays, Mountain Standard Time.*

*Don is now the sysop of GENie PSRT, where a special Resource Bin topic has been reserved for Nuts & Volts readers. For fast modem access, use (800) 638-8369 and enter HHH. When prompted, enter JOINGENIE. When asked for a keyword, enter DMD524.*

*You can also reach Don at Synergetics, Box 809, Thatcher, AZ 85552. Or send any messages to his Internet address of SYNERGETICS@GENIE.GEIS.COM.*



Don Lancaster's

# RESOURCE BIN

number one

## Starting off your resource quest

**W**elcome to my brand new *Nuts & Volts* column. Our prime focus will be in pinning down hard-to-find sources, ideas, reprints, hardware, software, and publications. But just about anything is likely to show up. And probably will.

To make this much more than just a one-way column, I have now added a no-charge voice helpline that you can call at my *Synergetics* for possible help on nearly any tech resource topic. Or for consultant referrals. Or for tinaja quests or for off-the-wall networking. Your best calling times are weekdays 8-5 Mountain Standard Time.

I have also just added a brand new *Nuts & Volts Resource Bin* topic to my PSRT RoundTable on *GENie*. Call (800) 638-9636 (voice) for local connect info. The average file downloading cost on PSRT is around twenty one cents.

You can directly contact other *Nuts & Volts* readers on this forum. You can reach me via my [SYNERGETICS] email address, once again on *GENie*. Among its hundreds of other files, I now do have my master names and numbers list up on *GENie* PSRT as our #330 NAMENUMS.GPS. These names are also available in several of my ongoing Book-on-demand published reprints. And I have now got a free insider's top secret resources brochure waiting for you if you call or write.

### Your best resource of all

I thought we might start off with the fundamentals of how to pick up info on anything. What is the single most important resource for nearly any *Nuts & Volts* reader? No, not an oscilloscope. No, not a soldering iron. Instead, it is a "magic" book that you have probably never even heard of.

It is known as *Uhlricht's Periodicals Dictionary* and you can find it on the reference shelf of your local library.

What Uhlricht's does for you is list 50,000 or so magazines. Many of these

are *trade journals*. And trade journals are where the ultimate action lies in any field. Directly, trade journals give you lots of up-to-date tech stories and bingo-cardable ads. Indirectly, they lead you to data books, catalogs, free samples, seminars, contacts, useful directories, and scads more.

Many trade journals are sent free to a highly selected group of insiders. This usually gets done to qualify for a special controlled-circulation postal rate. You might sometimes qualify by using nothing but a phone call or a properly laser-printed letterhead. To try, you ask them for a subscription qualification card.

A few examples of the electronic trade journals do include *E.E. Times*, *EDN*, *Electronic Design*, and *Electronic Products*. A pair of fine mechanical design trade journals include *Machine Design* and *Design News*. There are lots more where these came from.

To give you a further taste of the incredible variety of trade journals, a few I currently subscribe to include *Fire Engineering*, *Sensors*, the *Pollution*

tutorials, and specialty book sales.

There is also that oversize *Thomas Registry of Manufacturers* which can show you pretty near everybody that makes anything. But this tends to be overrated and is often out of date in fast-changing fields.

An extremely little known resource that is almost magic: It is called the *Science Citations Index*. Unlike other references, this one can let you move *forward* through time. Just start with any original "horse's mouth" author. Any time a newer paper mentions them in a bibliography or footnote, you've got a more recent reference.

For instance, anything new on active filters *has* to reference *Sallen and Key*. Anything related to unfocused solar collectors *has* to reference *Winston*, and so on.

You then use the new authors and the *avalanche effect* to generate newer and more current references.

But the library resource that I've found second only to my trade journal access is that...

### Dialog Information Service

At two dollars per minute typical charges, *Dialog* might seem expensive at first glance. But, if used properly, *Dialog* is far and away your cheapest and fastest way to find out everything and anything on any scholarly topic. From untold zillions of international conferences and pubs.

*Dialog* gives you instant on-line access to thousands of data bases. A tiny corner of *Dialog* is *INSPEC*. This can give you a paltry twenty million up to date references to electronic, computer, and physics topics. You can also try *MATHSCI* and *COMPENDEX*.

For instance, from just knowing the two words "magnetic refrigeration" to having the two dozen key abstracts in hand took only twelve minutes and only cost me \$24. This in an explosive and highly secretive new field that is

**NEXT MONTH: How to find unusual or oddball integrated circuits.**

*Equipment News*, *Powder & Bulk Solids*, and *Paper, Film, & Foil Converter*.

One ploy that usually works to pick up a copy of nearly any magazine or trade journal is the *SCAR* technique. Just ask for a sample copy and their ad rates from their ad department.

### Other library stuff

There are several other obscure library tools that you just might find useful. The *Encyclopedia of Associations* shows who is doing what in your field of interest. Many of the groups listed will also have trade shows, seminars,

new from  
**DON LANCASTER**

**ACTIVE FILTER COOKBOOK**

The sixteenth (!) printing of Don's bible on analog op-amp lowpass, bandpass, and highpass active filters. De-mystified instant designs. **\$19.50**

**CMOS AND TTL COOKBOOKS**

Millions of copies in print worldwide. THE two books for digital integrated circuit fundamentals. About as hands-on as you can get. **\$24.50** each.

**INCREDIBLE SECRET  
MONEY MACHINE II**

Updated 2nd edition of Don's classic on setting up your own technical or craft venture. **\$18.50**

**LANCASTER CLASSICS LIBRARY**

Don's best early stuff at a bargain price. Includes the CMOS Cookbook, The TTL Cookbook, Active Filter Cookbook, Micro Cookbooks I & II, newly revised Incredible Secret Money Machine II, and those Hardware Hacker II reprints. **\$119.50**

**LOTS OF OTHER GOODIES**

Ask the Guru I or II or III .....	\$24.50
Hardware Hacker II or III .....	\$24.50
Book-on-Demand Resource Kit .....	\$39.50
PostScript Beginner Stuff .....	\$39.50
Intro to PostScript Video .....	\$39.50
GENie PSRT Sampler .....	\$29.50
PostScript Reference II .....	\$28.50
PostScript Tutorial/Cookbook .....	\$16.50
Whole works (all PostScript) .....	\$349.50
PostScript Secrets Brochure .....	<b>FREE</b>
Hacking Secrets Brochure .....	<b>FREE</b>

**POSTSCRIPT SECRETS**

A Book/Disk combination crammed full of free fonts, insider resources, utilities, publications, workarounds, fontgrabbing, more. For most any PostScript printer. Mac or PC format. **\$39.50**

**BLATANT OPPORTUNIST I**

The reprints from all Don's Midnight Engineering columns. Includes the case against patents, book on demand publishing, toner secrets, paradigm stalking, insider research, lots more. **\$24.50**

**FREE SAMPLES**

Well, nearly free anyway. Almost. Do join us on GENie PSRT to sample all of the Guru's goodies. The downloading cost on a typical Guru file is 21 cents. Call (800) 638-9636 for connect info.

FREE VOICE HELPLINE VISA/MC

**SYNERGETICS**  
Box 809-NV  
Thatcher, AZ 85552  
(602) 428-4073

as much as fifty times more efficient than conventional refrigeration.

While you can subscribe to Dialog yourself, it is usually much faster and cheaper to work closely with your

local librarian. The costs for all of the manuals and reference materials get out of hand otherwise. And carefully worded searches can easily save you lots of big bucks.

Dialog has now introduced their quarter price late evening rate. At \$25 per hour, this is only somewhat more expensive than many of the other BBS services. Dialog is also available on CD ROM. Check your local university for more access details.

**Getting reprints**

I get dozens of calls a week from people living in "such a remote area" that they "just can't find" any way to get a reprint on any technical info. Since two of these "remote areas" have included Cambridge MA and Palo Alto CA, I've decided there are those of you out there who couldn't find a pig in a dishpan.

In reality, it is trivial to pick up any reprint from anywhere. I'm sitting here on my sand dune smack in the middle of the Upper Sonoran desert, and have never had any trouble at all getting reprints on anything from anywhere. Even for research literally done up on wilderness fire towers or even underground by carbide light. So please don't give me any of this "remote" bull.

There are three useful sources for reprints. These vary bunches in speed and price. Your cheapest usually gets called the *Interlibrary Loan Service* and is available at any library. All you have to do is ask.

The best all-around reprint source is *UMI*, who used to call themselves *University Microfilms*. They stock one each of everything. You do, of course, have to know the exact journal, page numbers, and author.

Finally, you can get many reprints directly from Dialog, either instantly on line or in a few days via fax or mail. But this costs more than UMI.

**Technical books**

Technical books place a very distant third behind all the trade journals and Dialog. But these certainly can be a valuable resource. As you may have noticed, libraries tend to only have older and usually non-paperbound texts. And mall storefronts having a "bookstore" sign in front of them often end up less than useless.

Instead, you want to keep your eyes out for obscure specialty direct mail bookstores. Who, for one reason or another, have some vested interest in

stocking all of the best tech books in a narrow field. From all the available publishers in the field.

For instance, *Lindsay Publications* can't be beat for their machine shop reprints and early radio titles. The *MIX Bookshelf* is far and away the best place to go for electronic music info. For automotive electronics, it's *SAE*.

For off-the-wall and utterly bizarre perpetual motion and free energy stuff, *High Energy Enterprises*.

Or, for one of the very few walk-in bookstores in the world that has an unlisted address, try *Singing Wind* for Southwest literature, lost mine lore, and assorted eclectic arcania.

Well, maybe one hint. Go north on Ocotillo road out of Benson, Arizona until it feels about right. Then hang right just past the seventh cow.

Here at my own *Synergetics*, I try to stock autographed copies of all my books and reprints, along with only the best of PostScript titles from other leading authors.

Your trick, of course, is to collect all of these specialty bookstore catalogs and mailings ahead of time. Your own resource files should always be your first place to look.

**Networking**

Networking is simply asking others for help. These can be real people in the case of work associates, technical hotlines, community college courses, ham radio clubs, or computer user groups. Local or national.

Or you can pick the electronic BBS route. There are tens of thousands of electronic bulletin boards up today. With general or special interests that can apply to pretty near anything or anyone. These are by far the fastest and cheapest way to link yourself up with experts in just about any field, technical or otherwise.

There are four electronic boards which are head and shoulders above the rest. The first two of these are *GENie* and *CompuServe*. *GENie* alone has nearly 125,000 files and programs available for your downloading at costs averaging around twenty one cents each.

Besides my own PSRT RoundTable on GENie, other areas here that you will find of more than passing interest do include MAC, IBM, RADIO (for its useful tech downloads), HOSB (for home office and small business) and DTP (for desktop publishing). There are many hundreds more.

A third superb BBS is *The Well*. This

online Whole Earth offering is now very heavy into the areas of alternate energy, small-is-beautiful, and similar right livelihood topics.

And finally there is *UseNet*, which forms the greatest piracy cove in the known universe. The time from when someone decides to keep some code a secret till the time a fully decrypted, explained, and the greatly improved version appears on UseNet is usually measured in nanoseconds. In several cases, the response time clearly has exceeded the speed of light. To gain free UseNet access, you will have to ask around at your local university. UNIX-based UseNet is also known as *Anarchy 101* among its denizens.

### Two magazines

There is at least one magazine set up specifically for new computer and technical startups. This is *Midnight Engineering*. You'll find bunches of stuff here that is flat out not covered elsewhere on the perils and pitfalls of any new product development and introduction. Free sample copies are available on request.

I do author my *Blatant Opportunist* column here which looks at emerging technical happenings suitable for any small scale startups.

A second quarterly journal that no researcher can afford to be without is the *Whole Earth Review*. Their original "access to tools" charter remains alive and well after several decades of their outstanding reporting. And just about an essential tool itself.

### Establishing credibility

The deck gets very much stacked against independent and small scale research to start with. So you certainly don't want to make things any worse than they already are.

In much of the real world the way things are perceived are accepted as reality. Thus, you definitely *do not* want to volunteer to anyone that you are a student, a startup, or lacking in "accepted" credentials. You definitely *do* want to use your own laser printed letterhead, have a properly registered company name (\$15 or so in typical states and trivial to do), and always answer your phone in a professional and business-like manner.

For some strange reason, most large technical firms tend to treat apparent higher volume customers better than any random callers. So, cause them to think they heard what they thought they wanted to hear.

## IMPORTANT RESEARCH RESOURCES

### CompuServe

5000 Arlington Center Blvd.  
Columbus, OH 43220  
(800) 848-8199

### Design News

44 Cook Street, #210  
Denver, CO 80206  
(303) 388-4511

### Dialog Info Service

3460 Hillview Avenue  
Palo Alto, CA 94304  
(415) 858-2700

### EDN Magazine

275 Washington Street  
Newton, MA 02158  
(617) 964-3030

### EE Times

600 Community Drive  
Manhassat, NY 11030  
(516) 365-4600

### Electronic Design

611 Route #46 West  
Hasbrouck Ht, NJ 07604  
(201) 393-6060

### Electronic Products

645 Stewart Avenue  
Garden City, NY 11530  
(516) 227-1300

### Encyc. of Associations

835 Penobscot Bldg.  
Detroit, MI 48226  
(313) 961-2242

### GENIE

401 N. Washington Street  
Rockville, MD 20850  
(800) 638-9636

### High Energy Enterprises

PO Box 5636  
Security, CO 80931  
(719) 475-0918

### Inspec/IEEE

445 Hoes Lane  
Piscataway, NJ 08855  
(908) 981-0060

### Lindsay Publications

PO Box 538  
Bradley, IL 60915  
(815) 468-3668

### Machine Design

1100 Superior Avenue  
Cleveland, OH 44144  
(216) 696-7000

### Midnight Engineering

111 E Drake Road #7041  
Ft Collins, CO 80525  
(303) 491-9092

### MIX Bookshelf

6400 Hollis Street #12  
Emeryville, CA 94608  
(800) 233-9604

### Paper, Film & Foil

29 N. Wacker Drive  
Chicago, IL 60606  
(312) 762-2802

### Polution Equipt. News

8650 Babcock Blvd  
Pittsburgh, PA 15237  
(412) 364-5366

### Power & Bulk Solids

PO Box 640  
Morris Plains, NJ 07950  
(201) 292-5100

### SAE

400 Commonwealth Drive  
Warrendale, PA 15096  
(412) 776-4841

### Sensors

174 Concord Street  
Peterborough, NH 03458  
(603) 924-9631

### Singing Wind

Ocotillo Road, Box 2197  
Benson, AZ 85602  
(602) 586-2425

### Synergetics

Box 809  
Thatcher, AZ 85552  
(602) 428-4073

### Thomas Registry

1 Penn Plaza  
New York, NY 10119  
(800) 222-7900

### Uhlricht's Dictionary

1180 Americas Avenue  
New York, NY 10016  
(212) 916-1600

### UMI

300 North Zeeb Road  
Ann Arbor, MI 48106  
(800) 521-3044

### The WELL

27 Gate Five Road  
Sausalito, CA 94965  
(415) 332-4355

### Whole Earth Review

27 Gate Five Road  
Sausalito, CA 94965  
(415) 332-1716

Just do remember that sincerity is everything. Once you have that faked, all else follows.

I've gathered most of our resources together into a new *Names & Numbers* sidebar. Be sure to check here before calling our technical hotline.

### A Contest

Bunches more on pinning down useful resources appears in a newly revised second edition of my *Incredible Secret Money Machine*. By one of those absolutely astonishing coincidences that seem to infest this column, I just happen to have autographed copies waiting here for you when you call the helpline below.

Let's have a contest here. To enter, just tell me about any little known or unusual resource. There will be a dozen or more autographed *Incredible Secret Money Machine* prizes, plus an all-expense paid (FOB Thatcher, AZ) *tinaja quest* for two going to the very best entry of all.

If possible, include a catalog or put me on their mailing list. Do be sure to send your written entries to me at the address below, and not to the *Nuts & Volts* editorial.

As with most of my contests, your chances of winning something are very good. Let's hear from you. ♦

*Microcomputer pioneer and guru Don Lancaster is the author of 28 books and countless articles. He now maintains a no-charge tech helpline found at (602) 428-4073, besides offering all of his own books, reprints, and his consulting services. He also has a free brochure full of his resource secrets waiting for you. Your best calling times are 8-5 on weekdays, Mountain Standard Time.*

*Don is the sysop of GENIE PSRT, where a special Resource Bin topic has been reserved for Nuts & Volts readers. You can call GENIE at (800) 638-9636 (voice) for connect info. Or you can reach Don at Synergetics, Box 809, Thatcher, AZ 85552.*



Don Lancaster's

# RESOURCE BIN

number ten

## Oddball sources for just plain stuff.

**O**ur usual reminder here that the *Resource Bin* is now a two-way column. You can get tech help, consultant referrals and off-the-wall networking on nearly any electronic, *tinaja questing*, personal publishing, money machine, or computer topic by calling me at (602) 428-4073 weekdays 8-5 MST. I've got a free pair of insider secret resources brochures waiting for you when you call or write.

An area of the great *GENie* PSRT at (800) 638-9636 (for voice info) has been set aside specifically for use by all of you *Nuts & Volts* readers.

This month, I thought we'd look at some unique and unusual sources for ordinary old stuff. The mechanical bits and pieces you can use to tie all your electronics together. Or simply places which have products so weird or unusual that you'd probably want to know all about them. Just because they are there.

Before we begin, just how can you put together your own resource file of preferred reliable sources? Naturally, we would hope you would begin with all our fine *Nuts & Volts* advertisers, and then mosey on to those *Names & Numbers* directories in the *Resource Bin* previous columns.

Yes, all my back columns, a cross reference index, and a master names and numbers directory have now all been gathered together into one single new Book-on-demand volume. Check my nearby *Synergetics* ad for details. You could also quickly and cheaply access this info on my *GENie* PSRT.

All of those industry trade journals are your prime method of finding out who sells what to whom. We've seen bunches on trade journals in previous columns. We have also seen that the *Uhlricht's Periodicals Dictionary* on the reference shelf of your local library is a superb starting point to pin down just who is now publishing what for whom. Many trade journals are free if

you tell them what they want to hear on their qualification cards.

Once you have access to the actual magazines, you use the reader service cards to get your catalogs, data sheets, samples, the local distributors, annual directories, and such.

Another way to pick up some trade journals is simply to keep your eyes and ears open. Especially in reception areas or waiting rooms of firms doing tasks wildly different from your own. Never flip past a bingo card without ripping it off! Unthinkable.

Besides Uhlricht's, most any library also gives you lots of other hints and tips. Especially in that *Encyclopedia of Organizations* and the gigantic *Thomas Registry of Manufacturers*

Your final obvious route to unusual stuff resources is to just ask anyone involved in anything really weird or strange. The chances are that they will happily talk your ear off.

For instance, you might not be too interested in model railroading. But *Model Railroader* has zillions of ads for miniature tools and materials. Even such exotic goodies as photochemical etch milling.

Many firms that cater to ceramics people, stained glass artisans, beef ranchers, blacksmiths, watchmakers, dentists, bulldozer operators, or other specialties do tend to target all of their advertising so tightly that you'll never

**NEXT MONTH: Don looks at the electronic books which really made a difference.**

normally hear about them. Yet their catalogs are often crammed full of goodies that scream "use me".

Don't overlook the classified ads in the traditional newsstand magazines. There's some utterly amazing goodies tucked away in and around all those

*Popular Science* and *Popular Mechanics* fine print classifieds. Quickly leafing through your Yellow Pages at random can also reveal unexpected sources.

Your final route to unusual stuff is to simply spend a tad additional time wandering around any oddball store after you have picked out what you really wanted. Jot down all the names and addresses on packages of weird goodies. Then write them for catalogs, data sheets, samples, and distributor insider price lists.

Over the decades, I have gathered together a humongous master names and numbers list. Since I usually live in remote rural areas, I've gone out of my way to build up the best possible personal resource files. Let us take a tour of my favorite places to go for the bizarre and wondrous...

### Small Parts

Numero uno on our list, of course, would be *Small Parts*. This is by far the greatest robotics store in the world. Besides custom cutting small pieces of metal and plastics for you, they stock everything your hardware store never heard of. And, yes, you can order in single or very small quantities. Mix or match any way you like.

Small Parts is very big in most any type of hardware. Bolts, nuts, screws, plastic standoffs, gears, belts, O-rings, sheets, rods, shims, clutches, E-rings, balls, cork, clips, shafts, pins, springs, retainers, music wire, tools, the whole bit. Metric and English. They also get into such exotics as low melting point alloys and similar curiosities.

Their catalog and price lists are "must have" hacker resources.

### W. W. Grainger

Surely everybody knows all about *W.W. Grainger*. But just in case you don't, they are the leading electrical products distributor in the country. They've got warehouses in just about

any larger city. They are fairly liberal with their thick catalogs.

Grainger is now heavy into motors, tools, and electrical supplies. Heating, ventilation, air conditioning, timers, controls, fans, dehumidifiers, pumps.

I just bought a replacement hot tub blower from them. Only to find a tiny scrap of warranty paper in the bottom of the new motor box that tells me about *Ametek's* great low cost repair program for sick hot tub blowers. Oh well. Information is where you find it. The new motor was a perfect fit and works just fine.

Certain of the local Grainger stores will absolutely insist upon tax stamps, billable accounting, and paper before they'll sell to you wholesale. Others are largely walk-in. It does seem to depend on the local contractors and the unions. Full details on picking up all of the needed credentials and then forming your own small business or tech venture appear in my brand new *Incredible Secret Money Machine II*.

### McMaster-Carr

*McMaster-Carr* is where all industry goes to shop. They do stock virtually everything mechanical, all tools, and all of the bits and pieces you need to either build a factory or prevent one from falling apart. As Grainger, they have branches in many larger cities.

McMaster-Carr does distribute an incredibly thick catalog, but these are very hard to qualify for. Their prices are also not all that great. But they do certainly give a new meaning to the term "one stop shopping".

### Edlco

The name is short for *Educational Lumber Company*. These folks are into exotic hardwoods in a very big way. Especially the weird, the beautiful, or the unusual. Nothing like a piece of wenge or cocobolo to liven up a small electronic enclosure.

A free catalog is offered.

### Outwater Plastics

This outfit believes they are in the display fixtures business. They have a wildly mind-boggling assortment of low cost and potentially quite useful hardware for you electronic hackers. Plus all sorts of ways of hanging and showing things. They even now offer Grecian urns for writing odes on.

Once again, a fat and free catalog is offered. This one is a real page turner, chock full of "use me" stuff. Stuff that simply cannot be ignored.

### The Player Piano Company

How's that again? Yup, the *Player Piano Company*. They stock all of the replacement bits and pieces for you individuals restoring player pianos and similar coin operated self-playing musical instruments. As such, they really do get into exotic tools, strong adhesives, and odd materials. Plus a library of incredible books.

What they don't recognize is that they are really in the low pressure pneumatics business and much of what they have is ideal for innovative new hacker robotics.

### Satco

*Satco* normally sells primarily to the schools, prisons, and the industrial training facilities. But they will sell to individuals as well.

They have a wide selection of tools, materials, kits, books, and trainers related to industrial arts. Electronics, automotive, machine shop, plastic or metal casting, drafting.

Pricing is fairly reasonable on most items, and they do stock stuff that's extremely hard to find elsewhere.

### Modeling materials

Your local hobby shop probably has smaller quantities of most building stock. I have found it better to go to the actual sources for wider variety and far better prices. For aluminum, brass, and other metal sheets, rods, and tubes, try *K & S Engineering*. For styrene sheet stock and similar plastic items, use *Evergreen Scale Models*. And for "lumber" precisely cut in all of the train gauge and scale dollhouse sizes, *Northeastern Scale Models* is it.

For the larger pieces of flat display, exhibit and modeling materials, your best source is *Fomeboards*. These folks are strong in foam core plastics and similar base materials for architectural mockups, fancier point-of-purchase signs, trade show panels, and such.

Several highly unusual decorative sheeting materials are now sold by *Coburn*. These can include prismatic, holographic, foils, glow-in-the-darks, metallics, and lots of other stunningly attractive display materials.

One of my favorite sources for the traditional art supplies is *Dick Blick*, while the *Polyline* people are big on cases, labels, and packages for audio cassettes and VCR video cases. I use *Polyline* cases for my *Introduction to PostScript* videos. They also stock hard-to-find VHS spine labels.

new from

## DON LANCASTER

### ACTIVE FILTER COOKBOOK

The sixteenth (!) printing of Don's bible on analog op-amp lowpass, bandpass, and highpass active filters. De-mystified instant designs. \$24.50

### CMOS AND TTL COOKBOOKS

Millions of copies in print worldwide. THE two books for digital integrated circuit fundamentals. About as hands-on as you can get. \$24.50 each.

### INCREDIBLE SECRET MONEY MACHINE II

Updated 2nd edition of Don's classic on setting up your own technical or craft venture. \$18.50

### LANCASTER CLASSICS LIBRARY

Don's best early stuff at a bargain price. Includes the CMOS Cookbook, The TTL Cookbook, Active Filter Cookbook, Micro Cookbooks I & II, newly revised Incredible Secret Money Machine II, and those Hardware Hacker II reprints. \$119.50

### LOTS OF OTHER GOODIES

Ask the Guru I or II or III .....	\$24.50
Hardware Hacker II or III .....	\$24.50
Book-on-Demand Resource Kit .....	\$39.50
PostScript Beginner Stuff .....	\$39.50
Intro to PostScript Video .....	\$39.50
Genie PSRT Sampler .....	\$29.50
PostScript Reference II .....	\$28.50
PostScript Tutorial/Cookbook .....	\$16.50
Whole works (all PostScript) .....	\$350.00
PostScript Secrets Brochure .....	FREE
Hacking Secrets Brochure .....	FREE

### LASERWRITER SECRETS

A Book/Disk combination crammed full of free fonts, insider resources, utilities, publications, workarounds, fontgrabbing, more. For most any PostScript printer. Mac or PC format. \$39.50

### BLATANT OPPORTUNIST I

The reprints from all Don's Midnight Engineering columns. Includes the case against patents, book on demand publishing, toner secrets, paradigm stalking, insider research, lots more. \$18.50

### RESOURCE BIN I

A complete collection of all Don's Nuts & Volts columns to date, including a new index and his master names and numbers list. \$12.50

### FREE SAMPLES

Well, nearly free anyway. Almost. Do join us on Genie PSRT to sample all of the Guru's goodies. The downloading cost on a typical Guru file is 21 cents. Call (800) 638-9636 for connect info.

FREE VOICE HELPLINE VISA/MC

**SYNERGETICS**  
Box 809-NV  
Thatcher, AZ 85552  
(602) 428-4073

Write in 146 on Reader Service Card.

## SOME "PLAIN OLD STUFF" RESOURCES

### AIN Plastics

249 E Sandford Blvd  
Mt Vernon, NY 10550  
(914) 668-6800

### American Safety Razor

Razor Blade Lane  
Verona, VA 24482  
(703) 248-8000

### Aremco

PO Box 429  
Ossining, NY 10562  
(914) 762-0685

### Ark-Plas Products

Highway 178 North  
Flippin, AR 72634  
(501) 453-2343

### Bead Chain

110 Mountain Grove  
Bridgeport CT, 06605  
(203) 334-4124

### Dick Blick

PO Box 1267  
Galesburg, IL 61401  
(800) 447-8192

### Caplugs

2150 Elmwood Avenue  
Buffalo, NY 14207  
(716) 876-9855

### Castolite

PO Box 391  
Woodstock, IL 60098  
(815) 338-4670

### Clippard Minimatic

7390 Colerain Road  
Cincinnati, OH 45239  
(513) 521-4261

### Coburn Corp

1650 Corporate Road  
Lakewood, NJ 08701  
(201) 367-5511

### Devcon

30 Endicott Street  
Danvers, MA 01923  
(508) 777-1100

### DonJer

Ilene Ct Bldg 8  
Belle Mead, NJ 08502  
(800) 336-6537

### EDLCO

PO Box 5373  
Asheville, NC 28813  
(704) 255-8765

### Evergreen Scale Models

12808 NE 125th Way  
Kirkland, WA 98034  
(206) 823-0458

### Fastex ITW

195 Algonquin Road  
Des Plaines, IL 60016  
(312) 299-2222

### Fomeboards

2211 N Elston Avenue  
Chicago, IL 60614  
(312) 278-9200

### Fotofoil

4400 N Temple City Blvd  
El Monte, CA 91734  
(818) 444-4555

### Garden Fresh Replicas

PO Box 208  
Neosho, MO 64850  
(800) 545-7304

### Grainger

2738 Fulton Street  
Chicago, IL 60612  
(312) 638-0536

### Hello Direct

140 Great Oaks Blvd  
San Jose, CA 95119  
(800) HI-HELLO

### Hygenic Manufacturing

1245 Home Avenue  
Akron, OH 44310  
(216) 633-8460

### K & S Engineering

6917 W 59th Street  
Chicago, IL 60638  
(312) 586-8503

### Kepron Circuit Systems

630 Axminister Drive  
Fenton, MO 63026  
(800) 325-3878

### Kindt-Collins

12651 Elmwood Avenue  
Cleveland, OH 44111  
(216) 252-4122

### Klockit

PO Box 636  
Lake Geneva, WI 53147  
(800) 556-2548

### Hank Lee's Magic

PO Box 1359  
Boston, MA 02205  
(800) 874-7400

### McMaster-Carr

Box 54960  
Los Angeles, CA 90054  
(213) 692-5911

### Archie McPhee

PO Box 30852  
Seattle, WA 98103  
(206) 547-2467

### Robert A. Main & Sons

555 Goffle Road  
Wychkoff, NJ 07481  
(201) 447-3700

### Metalphoto

18531 S Miles Road  
Cleveland, OH 44128  
(216) 475-0555

### Northeastern Scale Models

PO Box 727  
Methuen, MA 01844  
(508) 688-6019

### Outwater Plastics

4 Passaic Street  
Wood-Ridge, NJ 07075  
(800) 526-0462

### Player Piano Company

704 E Douglas  
Wichita, KS 67202  
(316) 263-3241

### Polyline

16018-C Adelante St  
Irwindale, CA 91702  
(818) 969-8555

### Roper-Whitney

2833 Huffman Blvd  
Rockford, IL 61103  
(815) 962-3011

### Satco

924 S 19th Avenue  
Minneapolis, MN 55404  
(800) 328-4644

### Small Parts

PO Box 4650  
Miami Lakes, FL 33014  
(305) 557-8222

### Stock Drive Products

2101 Jerico Turnpike  
New Hyde Park, NY 11040  
(516) 328-0200

### Tandy Leathercraft

1400 Everman Parkway  
Ft. Worth, TX 76140  
(817) 551-9770

### Tuners Supply

88-94 Wheatland Street  
Somerville, MA 02145  
(800) 247-0702

### Uhlricht's Dictionary

1180 Americas Avenue  
New York, NY 10016  
(212) 916-1600

### United States Plastics

1390 Neubrecht Road  
Lima, OH 45801  
(419) 228-2242

### Value Plastics

3350 Eastbook Drive  
Ft. Collins, CO 80525  
(303) 233-8306

### J C Whitney

1917-19 Archer Avenue  
Chicago, IL 60680  
(312) 431-6102

### Zero Corporation

777 Front Street  
Burbank, CA 91503  
(818) 846-4191

## And bunches more...

There are lots of companies which specialize in strange little bits and pieces of stuff. *Caplugs* immediately comes to mind for lots of small plastic closures, caps, grommets, and seals. They do have bunches of free sample packs available. For extremely low cost connectors and snaps, try *Bead Chain*. They are ridiculously cheaper than nearly any electronic connector company for such things as student lab clip-on lashups.

Long ago and far away, I did several *digital logic microlab* projects that centered themselves on the Bead posts and spring clip connectors.

If its round and either sharp or dull, try *Robert A. Main*. These folks make every conceivable type of needle or pin or rod of just about any size. For everything from 78 RPM phonograph needles to carpet installing machines. A mind blowing collection of stuff that you suspected that someone had to make, but weren't sure who.

For the wildest collection of razor blades you have ever seen, you can check *American Safety Razor*. Up to eighteen inches (!) that do nasty stuff in the hog to bacon process. They are really fixed for blades.

Higher volume plastic and metal connectors, bushings, standoffs, and related hardware are offered in wide variety from *Fastex/ITW*.

Lower pressure pneumatic tubing and rubber sheeting can be insanely expensive from your typical sources. Instead, *Hygenic Manufacturing* offers bunches of both at very low cost. They mostly have dentists and hospitals as customers, but they'll sell to anyone. They also have several sample sheets available.

For flocks and flocking, traditional "cabbage duster" flock is still available through *DonJer* and aimed largely at school shop and artsy-craftsy markets. The more modern silk screened flock products are offered by *HIX*.

Castable plastics remain obtainable through *Castolite*, who are still at the same old stall after all of these years. Unusual sticky stuff in tubes and cans comes from *Devcon*. Sticks anything to anybody. Machinable, pourable, and otherwise unusual industrial ceramics are sold by *Aremco*.

An astounding variety of industrial waxes is available from *Kindt-Collins*. Everything from machinable wax for cheaply checking out CAD/CAM to a genuine document and wine bottle

sealing wax. Even water soluble waxes are offered.

Machinable wax is fully recyclable, besides eliminating wear and tear on tools and machines if the plans or feed rate are wildly wrong. It can also be used directly for lost wax casting.

Plastic companies tend to be hard to deal with. But two having reasonable prices and wide variety include *AIN Plastics* and *US Plastics*. And the two sources for miniature plastic fittings suitable for hobby and pneumatic robotics are *Ark-Plas* and *Value*. A very pricey source for miniature air components is *Clippard Minimatic*.

*Klockit* is mostly a source for huge grandfather clock kits. Hidden among their other gems are \$4 hygrometers that are essential if you are doing any laser printing.

For photo-on-aluminum dialplates and museum exhibit panels, you can try either *Metalphoto* or *FotoFoil*. These are super durable.

Hmmm. Looks like I am near the bottom of the list, and all that's left is a totally unrelated and disjointed pile of loose ends.

So, here are a totally unrelated and disjointed pile of loose ends: *Kepron* for printed circuit supplies and materials; *Hello Direct* for consumer telephone products; *Hank Lee Magic Factory* for all sorts of tricky magic toys, books, and special effects; *Roper-Whitney* for reasonably priced hand punches and professional layout tools.

Look at *Stock Drive Products*, for, of all things, stock drive products such as shafts, gears, bearings, supports, differentials, and mechanical kits; *Tandy Leathercraft* for unusual tools and materials, especially punches and perforators.

*J. C. Whitney*, of course for their claim of "everything automotive"; and *Tuner's Supply* for piano tuning tools, books, and replacement parts.

And, at the very bottom of our list *Zero Corporation* for rounded cans and boxes that make fine electronic cases and enclosures.

For the truly and utterly bizarre, don't forget *Archie McPhee*. Off in a corner all by themselves, they are the world's leading supplier for giant rubber iguanas and similar essentials.

### The ultimate neat stuff

No discussion of unusual products and supply sources can possibly be complete without our mentioning the synthetic kale now available through *Garden Fresh Replicas*. These people

take their phony kale seriously, folks. Actual, genuine, authentic, 100% real kale is used for the mold masters. The molds are destroyed after a custom crafted limited edition of a mere 35 replicas. After all, the fake kale would look – well – fake if it all ended up identical. And real powdered kale is used for the filler in the plastic resins injected for molding.

Just like the Russian invention of synthetic caviar, their final product is absolutely indistinguishable from the real-world original.

Except by taste.

### Two contests

Let's have a pair of contests for this month. Either (A) tell me about some obscure but truly great source for neat stuff, or else (B) come up with a new and a non-obvious use for synthetic kale. On (A), try to send me a sample catalog and get me on their mailing list. Or whatever.

There will be a dozen of my newly republished *Incredible Secret Money Machine II* book prizes awarded to the best, along with an all expense paid (FOB Thatcher, AZ) *tinaja quest* for two going to the very best of all.

Be sure to send all of your written entries directly to me at *Synergetics* per the end blurb, rather than to *Nuts and Volts* editorial.

By the way, your odds of winning most of our contests are extremely high. On typical contests most of the time, pretty near everyone ends up winning something. Unless I really get swamped with entries. Which only rarely happens.

As usual, we've gathered our *Names & Numbers* together into one sidebar. Be sure to check out the sidebar first before you contact our voice helpline for further technical help. ♦

---

*Microcomputer pioneer and guru Don Lancaster is the author of 28 books and countless articles. Don maintains his no-charge tech helpline found at (602) 428-4073, besides offering all of his own books, reprints, and all of his consulting services. He also has a free brochure full of his resource secrets waiting for you. Your best calling times are 8-5 on weekdays, Mountain Standard Time.*

*Don is now the sysop of GENie PSRT, where a special Resource Bin topic has been reserved for Nuts & Volts readers. You can contact GENie at (800) 638-9636 (voice) for connect info. Or you can reach Don at Synergetics, Box 809, Thatcher, AZ 85552.*



by Don Lancaster

# Stupendous Stuff Sources

**T**hree centermost key secrets to your personal technical, craft or art venture are (1) Becoming and keeping informed; (2) Not trying to reinvent the wheel; and (3) Not getting ripped off by your suppliers.

What I thought I'd do this month is reach way down into my super-secret personal resource file, and pull out the finest of the good guys for you...

## Advance Process Supply

400 North Noble Street  
Chicago, IL 60622  
(312) 829-1400

*Stocks a rather wide variety of silk screen materials and supplies, both for electronic and sign purposes. Their "fuzzy" self-flocking plastasol inks are rather unique.*

## AIN Plastics

249 East Sandford Blvd.  
Mount Vernon, NY 10550  
(914) 668-6800

*This plastics wholesaler has an in-depth selection of the engineering and commercial materials. Rigid vinyl is often a good and low cost choice for modelmaking uses.*

## APDA

20525 Mariani Avenue Bldg 33G  
Cupertino, CA 95014  
(800) 282-2732

*The Apple Programmer's and Developer's Association was cheaper and better when it was independent, but this is your best source for insider technical info and software on all Apple and Macintosh products. Their \$25 yearly membership remains a bargain.*

## Association of Energy Engineers

Box 1026  
Lilburn, GA 30226  
(404) 925-9558

*Professional and technical info on solar and wind energy is getting very hard to pin down, with practically all of the trade journals having folded. This one remains as a useful, although totally establishment, source. Also heavy into co-generation, and efficient appliances.*

## Dick Blick

Box 1267  
Galesburg, IL 61401  
(800) 447-8192

*A good direct mail art supply house, also heavy into silk screen and signmaking stuff. Lots of interesting materials available in small lots without staggering minimum orders.*

## BMUG

1442A Walnut Street #153  
Berkeley, CA 94709  
(415) 849-9114

*Probably the best all-around Macintosh user's group. Outstanding bound newsletters, public domain software, and shareware. Loosely associated with Farallon Computing.*

## C & H Sales

Box 5356  
Pasadena, CA 91107  
(800) 325-9465

*Here's where you go for surplus "big mutha" raw iron. Motors, instruments, hydraulics, steppers, valves, controls. Most at outstanding prices but limited availability.*

## Circuit Cellar Ink

4 Park Street Suite 20  
Vernon, CT 06066  
(203) 875-2751

*Steve Ciarcia's hands-on answer to my Hardware Hacking columns. Very heavy into computer applications, especially embedded microcontrollers. His other emphasis areas include security, machine vision, remote controls, and telecommunications.*

## Coburn

1650 Corporate Road  
Lakewood, NJ 08701  
(201) 367-5511

*Makes highly unusual and decorative sheet materials, including prismatics, foils, glow-in-the-darks, diffraction gratings, glitters. Some are laser printable; others are not. Sample evaluation packages available.*

---

**Constantine**

2050 Eastchester Road  
Bronx, NY 10461  
(212) 792-1600

---

*A woodworker's supply catalog. Heavy into exotic woods and veneers, unusual and quality tools. Free catalogs available.*

**Dialog Information Services**

3460 Hillview Avenue  
Palo Alto, CA 94304  
(415) 858-2700

---

*Hundreds of millions of technical references spread out over several hundred instantly accessible data bases. Far and away the best way to research any subject. Hint: use your local librarian. They can dramatically reduce costs. Typical price for 50 key abstracts in a field is around \$25.*

**Die-O-Perf**

1721 East Pioneer Drive  
Irving, TX 75061  
(800) 843-2807

---

*Has low cost die cut goodies that laser print beautifully. Stuff like perforated self-mailers, coupon sheets, rolodex cards, tickets, tags. Usual cost is a nickel a sheet.*

**ECG/Phillips**

70 Empire Drive  
West Seneca, NY 14224  
(716) 325-2620

---

*One of the two leading sources of repair, replacement, hacker, and educational semiconductors. Has outstanding cross references and technical mini-manuals. The competition includes NTE Electronics.*

**EDLCO**

PO Box 5373  
Asheville, NC 28813  
(704) 255-8765

---

*The name is short for Educational Lumber Company. Has all varieties of Appalachian hardwoods and exotic imports. Nothing like cocobolo or wenge to liven up your products. Reasonable prices, good delivery.*

**Edmund Scientific**

101 East Gloucester Pike  
Barrington, NJ 08007  
(609) 573-6250

---

*The yuppie reign of terror here has at long last ended, and the Perrier-filled birdbaths are no more. Edmund is once again a good source of optics, electronic surplus, and scientific stuff. Now has superconductivity kits.*

**Evergreen Scale Models**

12808 Northeast 125th Way  
Kirkland, WA 98034  
(206) 823-0458

---

*Precut white styrene for modelmaking uses, especially in the sizes favored by architects, model railroaders, and dollhouse builders. Stocked by some larger hobby shops.*

**Fair Radio Sales**

Box 1105  
Lima, OH 45802  
(419) 227-6573

---

*The oldest of the old line surplus houses, still stocking original World War II electronic gear. Particularly handy for older and higher voltage components, hard-to-get technical info. One of my favorites, I've bought everything from altimeters to servos from them.*

**Fomebords**

2211 North Elston Avenue  
Chicago, IL 60614  
(312) 278-9200

---

*Cardboard used to be cardboard and posterboard used to be posterboard, but today there are dozens of hi-tech materials available for architectural studies, models, and exhibits. Great stock selection.*

**Grainger**

2738 Fulton Street  
Chicago, IL 60612  
(312) 638-0536

---

*A major wholesale source for motors, air conditioners, electrical tools, and such. In most larger cities. Some locations actually try to enforce their wholesale-only policy, so you may need a letterhead and a tax stamp.*

**Heath Company**

PO Box 1288  
Benton Harbor, MI 49022  
(616) 982-3200

---

*The largest manufacturer of electronic kits in the world. Their self-study educational electronic courses are far better than any of the mail-order trade schools. Outstanding reputation and unconditional guarantees. No matter how much a mess you make of their products, they will fix them for free.*

**Home Power**

PO Box 130  
Hornbrook, CA 96044  
(916) 475-3179

---

*Appears to be the last remaining user-oriented alternate energy publication. \$10 per year. Full of ads and tech articles on solar power, low voltage appliances, and windmills.*

---

**Hygienic Manufacturing**

1245 Home Avenue  
Akron, OH 44310  
(216) 633-8460

---

*A great and very low priced source of rubber tubing and sheeting, as well as doing custom die-cutting. Far cheaper than most electronic materials sources.*

**Jerryco**

601 Linden Place  
Evanston, IL 60202  
(708) 475-8440

---

*The finest mail order surplus store in the world. Period. Where else can you get a matched set of 24 US Army urine specimen bottles for use as wedding presents? Insanely low prices on many items. Unusual materials for unusual uses. This one is a "must have".*

**K & S Engineering**

6917 West 59th Street  
Chicago, IL 60638  
(312) 586-8503

---

*Good source of modelmaking aluminum, stainless, and brass sheet and tubing in small sizes. Has racks in larger hobby shops.*

**Kepron Circuit Systems**

630 Axminster Drive  
Fenton, MO 63026  
(314) 343-1630

---

*Probably the best source for small quantity experimenter printed circuit materials and supplies. Use the dry resist pre-coated boards and their ammonium persulfate etchant for the best results.*

**Lazer Products**

12741 East Caley Suite 130  
Englewood, CO 80155  
(303) 792-5277

---

*Supplies for copier and laser toner cartridge reloading that can reduce your page costs by 15:1 or higher. Also hard recoats drums for extended life.*

**Lindsay Publications**

PO Box 583  
Manteno, IL 60950  
(815) 468-3668

---

*A unique direct mail book store that specializes in reprinting old machine shop and antique electronics texts. Hundreds of hands-on titles on everything from stained glass to perpetual motion machines. Request both of their free machine shop and electronic catalogs. Get on their mailing list.*

**Machine Design**

1100 Superior Avenue  
Cleveland, OH 44144  
(216) 696-7000

---

*A very good mechanical engineering trade journal. They are fussy about their free subscriptions, so sound like a real engineer when you fill out your qualification card.*

**McMaster-Carr**

Box 54960  
Los Angeles, CA 90054  
(213) 692-5911

---

*The super hardware stores that industry shops at. Branches in all larger cities. Try to cop one of their humongous 2400 page catalogs. Stocks at least one each of everything, but does not discount.*

**Robert A. Main & Sons**

555 Goffle Road  
Wyckoff, NJ 07481  
(201) 447-3700

---

*Makes a bewildering array of hooks, points, and pins. Not that they are at all old line or anything, but they still offer several different styles of 78 RPM phono needles. All the items in their catalog scream "Use me!".*

**Maxim**

120 San Gabriel Drive  
Sunnyvale, CA 94086  
(408) 737-7600

---

*Innovative smaller microchip manufacturer. Unique and low cost products include video switches, micropower regulators, supervisors, A/D & D/A, power op-amps, lots more. Chips that cry to be used.*

**Measurement and Control**

2994 West Liberty Avenue  
Pittsburgh, PA 15216  
(412) 343-9666

---

*A free trade journal with extensive ads and advertiser-written technical articles for sensors, transducers, and other industrial instrumentation. They also publish the Pollution Equipment News magazine.*

**Meredith Instruments**

6403 North 59th Avenue  
Glendale, AZ 85301  
(602) 934-9387

---

*The best hacker source for surplus lasers and related optics. Prices start around \$25. Also has a light show BBS up at (602) 867-7258.*

---

**Metalphoto**

18531 South Miles Road  
Cleveland, OH 44128  
(216) 475-0555

---

*Manufactures photosensitized and partially anodized aluminum plates. You expose these, develop them, and boil them in sealing glop to make very durable nameplates, front panels, or vandal-resistant interpretive signs.*

**MIX Bookshelf**

6400 Hollis Street Suite 12  
Emeryville, CA 94608  
(800) 233-9604

---

*Probably the largest collection in the world on audio, electronic music, television, and video production books and software. Associated with both MIX Magazine (audio production) and Electronic Musician (synthesizers, etc.).*

**Model Railroader**

1027 North 7th Street  
Milwaukee, WI 53233  
(414) 272-2060

---

*Besides unusual tools and techniques, this hobby magazine has far and away the finest technical writing and technical illustration of any publication anywhere ever. Use it as a style and layout manual, and hope to someday be able to communicate that well. Should be required reading for any tech writer.*

**Motion Magazine**

Box 6430  
Orange, CA 92613  
(714) 974-0200

---

*Free trade journal that covers steppers, servo motors, linear actuators, the power control semiconductors, and general robotics stuff. Pricy products but full of good technical ideas and resources.*

**Mouser Electronics**

11433 Woodside Avenue  
Santee, CA 92071  
(800) 346-6873

---

*Electronic distributor with low minimums, low pricing, and extensive stock. Very hacker friendly. Carries semiconductors, ic's, relays, resistors, capacitors, inductors, hardware, and all the usual goodies. Largely imports.*

**Northeastern Scale Models**

PO Box 727  
Methuen, MA 01844  
(508) 688-6019

---

*Precision precut wood shapes in the sizes used by architects, model railroaders, and dollhouse builders. Think of them as a miniature lumberyard.*

**NTE Electronics**

44 Farrand Street  
Bloomfield, NJ 07003  
(201) 748-5089

---

*The second major source of semiconductors for replacement, service, education, and hacker experimenting. A virtual carbon copy of ECG, they also have lots of good cross reference and technical data books available.*

**Nuts and Volts**

Box 1111  
Placentia, CA 92670  
(714) 632-7721

---

*An all-ads mail order shopper specifically for hardware hackers, ham radio operators, CB folks, computer users, and satellite pirates. Their low-price ads are attractive for most shoestring technical startups.*

**PaperPlus**

300 Oceangate #800  
Long Beach, CA 90802  
(800) 272-7377

---

*If you've ever tried buying paper from an old line source, you know the hassles. Instead, try these walk-in paper supermarkets now in most states. Especially useful for book-on-demand publishers. Also stocks certificates, bumper sticker stock, acetates and polyesters.*

**PCIM**

2472 Eastman Avenue  
Ventura, CA 93003  
(805) 658-0933

---

*Used to be called Power Conversion and Intelligent Motion. Another free trade journal for the robotics crowd. Covers steppers, servos, motors, linear actuators, and their electronic control components.*

**Player Piano Company**

704 East Douglas  
Wichita, KS 67202  
(316) 263-3241

---

*Well, just because it is there, I guess. Unusual source for very unusual tools, materials, and techniques. Has hobby robotics potential, especially for low pressure pneumatics.*

**Printer's Shopper**

PO Drawer 1056  
Chula Vista, CA 92012  
(800) 854-2911

---

*Not really a shopper, but a monthly mail-order catalog for a major printing equipment tools, materials, inks, and supplies house. Many hundreds of items listed. Their prices are usually better than buying locally.*

---

**Quick Printing**

1680 Southwest Bayshore Blvd  
Port Saint Lucie, FL 34984  
(407) 879-6666

---

*Probably the best of the instant printer trade journals. Full of ads for papers, materials, tools, supplies, badges, bumperstickers, menus, and tags. Usually gives you several free copies and then will hit you up for an overpriced subscription.*

**Quill Office Products**

Box 4700  
Lincolnshire, IL 60197  
(312) 634-4800

---

*Traditionally a leading mail-order discounter of office products. These days, though, the local office supply superstores are giving them a run for the money. Wait for Quill's sales; they are often genuine loss leaders.*

**Radio-Electronics**

500-B Bi-County Blvd  
Farmingdale, NY 11735  
(516) 293-3000

---

*Yeah, I write for them. Even so, they are just about the best newstand electronic mag. They also publish Popular Electronics, which is really the old name wrapped around their own Hands-On Electronics.*

**Real Goods**

966 Mazzoni Street  
Ukiah, CA 95482  
(800) 762-7325

---

*A major direct-mail supplier of alternate lifestyle products, including home power, home business, home craft type of goodies. One of the last of a vanishing breed.*

**Rohm Corporation**

8 Whatney  
Irvine, CA 92713  
(714) 855-0819

---

*US distributor of unique integrated circuits including FM wireless stereo broadcasters, melody chips, plus bunches of similiar consumer electronic goodies. Free catalogs and often free samples. Very low prices.*

**SAE**

400 Commonwealth Drive  
Warrendale, PA 15096  
(412) 776-4840

---

*Used to be the Society for Automotive Engineers. This one is about as establishment as you can get, but they do stock a wide variety of books and monographs on car electronics, unusual engines, and vehicular technology in general.*

**Samsung Semiconductor**

3725 North First Street  
San Jose, CA 95134  
(408) 434-5400

---

*Distributor of a mind-blowing variety of Korean microcircuits. To any hardware hacker, their data books (especially Linear, Volume I) reads like a page-turning pulp novel. Their low cost chips are all "gottahaves".*

**SignCraft**

1938 Hill Avenue  
Fort Myers, FL 33906  
(813) 939-4644

---

*The very best magazine for the sign painting trade. Their competitors are too hung up on snotty billboard politics. Signcraft can be an excellent idea source, besides containing ads for unusual tools and materials.*

**Small Parts**

Box 381966  
Miami, FL 33238  
(305) 751-0856

---

*The greatest robotics store in the world, only they don't know it. Besides their stocking everything your hardware store never heard of, they custom cut smaller quantities of aluminum, brass, and plastic sheet, rod, or extrusions for you. Small orders welcome.*

**Southern Sign Supply**

127 Roesler Road  
Glen Burnie, MD 21061  
(301) 768-8600

---

*A competitor to Advance, these folks also stock silk screen materials and specialized tools for printed circuit and commercial use. Big fat catalog. Reasonable prices.*

**Speleonics**

Box 5283  
Bloomington, IN 47402  
(812) 339-7305

---

*One of my favorite examples of an extremely well done "labor of love" technical newsletter, this one covers technical stuff of interest to cavers. Covers the very low frequency radio communications, direction finding, altimeters, improved light sources, more.*

**Surplus Traders**

Winters Lane Box 276  
Alburg, VT 05440  
(514) 739-9328

---

*The old ETCO operation set up for direct mail surplus electronics. Ridiculously low prices on many items. As with all electronic surplus, availability is on a catch-as-catch-can basis.*

---

**Synergetics**

Box 809  
Thatcher, AZ 85552  
(602) 428-4073

---

*Sneaky, huh? Synergetics is me, stocking lots of classic books on hardware hacking, as well as the ongoing book-on-demand published reprints from my columns. PostScript, too.*

**Thompson and Thompson**

23072 Lake Center Drive #100  
El Toro, CA 92630  
(714) 855-3838

---

*Has very good pricing on modified and rebuilt PostScript laser printers. Manufactures those glompenstractors and other essential tools for toner cartridge reloading. Has a free helpline.*

**3M Scotch Color Key**

3M Center B 223-2N-01  
Saint Paul, MN 55144  
(800) 328-1186

---

*Color Key is an unusual photographic material intended for color proofing. But it has zillions of other uses, for anyplace you'd want to (1) reverse a photographic image, or (2) create an image using clear and colored areas on a plastic sheet. No darkroom needed. You contact print in the sun and develop by wiping on glop. Be sure to check out their related do-it-yourself Scotchcal dialplates.*

**Transfer Print Foils**

Box 518  
East Brunswick, NJ 08816  
(201) 238-1800

---

*One of the leading suppliers of foils for hot stamping and custom printing. And, their free Foiled Again newsletter is something you gotta get on its name alone.*

**U&lc**

2 Dag Hammarskjold Plaza  
New York, NY 10017  
(212) 371-0699

---

*One of the most bizarre free trade journals in the world, U&lc covers Upper and Lower Case typography. Free alphabets and off-the-wall layout ideas with each oversize issue. Be sure to sound like an ad agency art director when requesting your free sub.*

**Uhlricht's Periodicals Dictionary**

1180 Avenue of the Americas  
New York, NY 10016  
(212) 916-1600

---

*Herein lie the keys to the kingdom. Found on the reference shelf at your local library, this gem lists over 50,000 trade journals, many of them free. If I were to shorten this resource directory to a single entry, Uhlricht's would be it, hands down. No contest.*

**UMI**

300 North Zeeb Road  
Ann Arbor, MI 48106  
(800) 521-3044

---

*They used to be called University Microfilms International. They can get you a reprint of most anything printed anywhere. Faster than interlibrary loan, and cheaper than Dialog. You do have to know exactly what you want.*

**Unibind**

4125 Prospect Drive  
Carmichael, CA 95608  
(916) 967-6401

---

*Supplies the thermal perfect binding system I use for my book-on-demand publications. You jog your sheets, place them into a vinyl cover, and drop them in a toaster-style heater.*

**United States Plastics**

1390 Neubrecht Road  
Lima, OH 45801  
(408) 559-7778

---

*A good plastic wholesaler with a wide stock selection. Particularly strong on unusual fittings and adaptors you can't find locally.*

**Value Plastics**

3350 Eastbrook Drive  
Fort Collins, CO 80525  
(303) 233-8306

---

*The pneumatic components for low pressure robotics are often unreasonably expensive. These folks have lots of cheap connectors and connector systems, including a line of custom you-bond-it manifold kits.*

**Van Dyke's Restorers**

Woonsocket, ND 57385  
(800) 843-3320

---

*Yet another unusual source for parts, tools, and ideas. These are aimed mostly at antique and restoration buffs. Has exotic woods.*

**Velo-Bind**

650 Alamanor Avenue  
Sunnyvale, CA 94086  
(800) 538-1798

---

*Their Personal Velobinder system is an attractive way of binding 30 or fewer sheets together in a non-perfect, but reasonably professional manner. You can pick your own cover materials, or else use theirs.*

---

**Roger Wagner Publishing**  
1050 Pioneer Way, Ste P  
El Cajon, Ca 92020  
(619) 442-0522

---

*Roger's Hyperstudio is a mentor class product for the Apple IIs. This Hypercard-style package provides excellent sound and full color graphics. It includes a microphone and all necessary hardware.*

**Guy Wicker**  
30437 Fairfax  
Southfield, MI 48076  
(313) 647-1820

---

*Cold fusion is very much in the news these days. Apparently the excess heat production is real and seems to have an atomic origin. Guy offers very low cost experimenter's cold fusion kits and related products.*

**Whole Earth Review**  
27 Gate Five Road  
Sausalito, CA 94965  
(415) 332-1716

---

*Still at the same old stall after all these years. The indispensable quarterly follow-up to the Whole Earth Catalog and progeny. Of the 437 magazines I subscribe to, this one is good old number two, and right up their behind MAD. Nothing else comes even remotely close. They are starting to publish on CD-ROM and also run The Well, a unique BBS system.*

**Woodworker's Store**  
21801 Industrial Blvd.  
Rogers, MN 55374  
(612) 428-2899

---

*The last of our woodworking triad that also includes Constantine and Edelco. Unusual and exotic woods and veneers, specialty tools, idea books, router bits, whatever.*

**Xicor**  
1511 Buckeye Drive  
Milpitas, CA 95035  
(408) 432-8888

---

*Their unique EEPOT products make fine low cost remote digital volume controls. Free samples on letterhead requests.*

. . . . .

Well, that is sort of a sampler of several of my very favorite resources. My entire *Names and Numbers* directory appears in the appendix. ♦

---

*Microcomputer pioneer and guru Don Lancaster is the author of 26 books and countless articles. Don now maintains a no-charge technical helpline you will find at (602) 428-4073, besides offering all of his own books, reprints, and various services. He also has a free brochure*

*chock full of his new insider desktop publishing secrets waiting just for you. Your best calling times are 8-5 on weekdays, Mountain Standard Time. Or you can reach Don by way of his Synergetics, at Box 809, Thatcher, AZ 85552.*





Don Lancaster's

# RESOURCE BIN

number twenty-two

## A look at online resources & opportunities

**O**ur usual reminder here that the *Resource Bin* is now a two-way column. You can get tech help, consultant referrals and off-the-wall networking on nearly any electronic, *tinaja questing*, personal publishing, money machine, or computer topic by calling me at (602) 428-4073 weekdays 8-5 MST. I've got a free pair of insider secret resources brochures waiting for you when you call or write.

A portion of my PSRT RoundTable on *GENie* has also been set aside for you *Nuts & Volts* readers. This is the place to go for instant tech answers. Among the many files in our library, you will find complete reprints and preprints for all of my *Resource Bin* columns. I've just added a new "fast access" feature for you. Have your modem dial (800) 638-8369, followed by HHH. Then `XTX99005,SCRIPT`.

A free *GENie* brochure if you voice call (800) 638-9636.

They are out there.

Tens of thousands of the online BBS bulletin boards. Through which you can immediately get in touch with the experts in *any* field. Or instantly pick up the latest inside info on *any* topic. Or meet new and unusual people. Or tap all sorts of entertainment services from G+ through XXX-. Or even buy a coconut-anchovy pizza.

The online services have gotten to the point where you can not afford to ignore them. All you'll need for access is a low cost modem and some comm software. If you can not find anything better, try *Crosstalk* or *ProComm* on a PC, *Microphone* on a Mac, or *ProTerm* on the Apple IIe. Just be certain your comm software has a *scrollback* feature where you can see previous screens. Plus a way of logging to disk.

There's also lots of nonobvious uses for BBS systems. Ferinstance, you can use most any old BBS to transfer files between host machines with different operating systems. Or time shift the

transfer for convenience. Simply have your source machine upload and your destination download. Naturally, the moved files may or may not be usable on your second machine. But at least they are on disk and readable.

It never ceases to amaze me that I can press one key on my *GENie* PSRT and instantly send email to zillions of users. At a cost per thousand of - zero. But do note that typical BBS users do not take at all kindly to junk email. It is very easy to do vastly more harm than good. The secrets here are to (A) keep it short, (B) limit it to genuinely useful *news*, and (C) use it rarely.

Let's check into what I feel are the most important online BBS resources today. Before we do, though, let's take a closer look at...

### The Downside

What's wrong with telecomputing today? Well, quite a bit.

Online access can be expensive. The only bigger surprise than your first \$468.74 phone bill occurs when your sixth grade son or daughter racks up a \$4,687.40 one instead.

There are lots of ways to reduce all of your telecomm costs. Practice and higher speed modems are the obvious first steps. Use the cheaper and closer

**NEXT MONTH: Don looks at the tools & test equipment that can be cost effective.**

services until you become comfortable with your BBS comm. Download all the instructions and the menus so you can avoid relisting them online. There are quite a few programs (such as *GENie's Alladin*) that can give you a faster and automated access. Knowing all your phone fees and the hours they apply can also help a lot.

Simply LISTING files can be faster

and cheaper than using XMODEM or its improved offspring. But note that a listing permits comm errors. Still, if you have clean lines and are looking at tutorials, text, or at uncompressed code in a language that you are adept at, you might save big bucks.

At worst, you might have to relist every now and then.

Most BBS stuff is extremely diffuse. You have to wade through a lot of chaff to get to the wheat. Just about all of the services need vastly improved *you are here* coding, better *sideways* navigation, and new *global* all-forum search capability. Cross linked access gateways between the main services also need to be provided. There is no sane reason why you should not be able to instantly flip between a *GENie* Roundtable and a *CompuServe* Forum.

User interfaces on most boards are still rather primitive. Cuniform and clay tablet even. Old text interfaces are absurd in this day and age. And those graphic user interfaces are still poor. Most users quickly abandon any on-line graphic interfaces for better third party host-based ones.

Your four most desirable BBS info interfaces are (A) Device independent, camera-ready, and license free total text/graphics pages; (B) Ready-to-use software program files; (C) CD quality digital audio; or (D) HDTV animated MPEG compressed video.

I routinely offer (A) all the time on my *GENie* PSRT. Our ultra-short and ultra fast textfiles instantly give you camera ready art on *any* computer. At 11K for routine uncompressed pages. License free and with no special user software. I use the *triple distilled raw PostScript* method we looked at in my previous columns and in those *Blatant Opportunist* reprints.

Others will shortly begin offering Adobe's *Acrobat* system, which is far klutzier and requires special software to run their longer and slower files.

As before, I'd be most happy to help you offer cheap device-independent and camera-ready text/graphic files. All you have to do is ask.

Compression remains an absolute zoo. Among the main platforms, there are a dozen choices in use. Many BBS systems might serve a wide variety of users on an even wider assortment of host computers. You'll see everything from Crays to Commodores.

Now, there are a very few system specific files in which it might seem reasonable to insist on one particular compression scheme. But it makes far more sense to offer a choice of *global compression* to the user.

Wherein *everything* requested gets squashed using their favorite scheme. Each BBS would have some internal compression they use. On a request, they could decompress to raw text or re-encode to any desired format on your downloading.

I have found that compression can often *increase* your downloading costs. Especially if you can LIST a raw file, instead of having to XMODEM one or more squashed file.

On my PSRT, we studiously avoid compressing files under 100K, unless they are extremely host specific. We do try to make as many of our files as device independent as possible. Most of them will run equally well on any Mac or PC, an Amiga or an Apple, an Atari or a Commodore. And produce identical camera-ready output from the very same textfile.

Finally, you are likely to run into some very strange denizens on those BBS systems. Many who prefer heat to light. All bets are off anytime after 3 AM. Pretend it is a zoo. But watch out for those aardvarks.

They will get to you every time.

But don't let any of these negatives stop you. These are all problems that are quickly getting repaired. Ignoring telecomputing in this day and age is sheer stupidity.

On to the major players...

### Dialog Information Service

I still get all of these mind-numbing helpline calls from people who claim they live in such a "remote" area that they can't find technical information. From such places as Cambridge, MA and Palo Alto, CA even.

Well, here I am sitting on my sand dune in the the Upper Sonorian desert watching Gila Monsters. I have done first rate research up on wilderness fire towers or worked underground in

largely unexplored caves.

So, I can assure you first hand that today, *there is no location on, beneath, or above this planet that is still "remote"*. Period. So don't give me any "remote" bull. Tell it to your therapist.

If you can't find it, you ain't lookin'.

The online research resource which has been the greatest equalizer for me has been the *Dialog Information Service*. Yes, they are obscenely expensive and are woefully old line. Until you work in that good old *Uh, compared to what?* factor. Then it is no contest.

Dialog is largely a broker of online information compiled by others. They have some 400+ services they provide. Nearly everything from Medline to the Denver Post. At last count, they had a half *billion* references instantly available. Areas covered are science, technology, law, medicine, patents, history, reference works, political, economics, and bunches more.

My three favorite data bases here are COMPENDEX, MATHSCI, and INSPEC. Not too long ago, I needed an update on fluxgate magnetometers for my *Hardware Hacker* column over in *Electronics Now*. These are *the* solution to solid state compasses, robotic nav, and archaeological exploration. Well, getting the key abstracts of the latest and best info available through Dialog only took a few minutes and cost me around \$24.

I also like the library resources that Dialog offers. Especially *Uhlricht's, Books in Print*, and the *Encyclopedia of Associations*. Others might find their extensive patent resources helpful. Or all their employment listings. Or their thesis abstracts. Or their listings for thousands of foundations which give lots of money away.

Dialog has recently shown up on CompuServe and GENie. Actually, the GENie service is really a CompuServe top secret crosslink.

These new services are cash and carry, meaning that you pay only for results and nothing extra for online time. Ferinstance, a search that finds something costs you \$2.50. If it misses, it is only \$1.50. A listing of found titles is thirty cents per title. The abstracts do remain pricey at \$3 each.

All of which usually ends up only somewhat cheaper than using Dialog from your local library. Searches cost less, but the abstracts cost more. But it sure is convenient to instantly have 24 hour home access to all the significant research ever done anywhere.

Dialog also provides direct subs at

## new from DON LANCASTER

### ACTIVE FILTER COOKBOOK

The sixteenth (!) printing of Don's bible on analog op-amp lowpass, bandpass, and highpass active filters. De-mystified instant designs. **\$24.50**

### CMOS AND TTL COOKBOOKS

Millions of copies in print worldwide. THE two books for digital integrated circuit fundamentals. About as hands-on as you can get. **\$24.50** each.

### INCREDIBLE SECRET MONEY MACHINE II

Updated 2nd edition of Don's classic on setting up your own technical or craft venture. **\$18.50**

### LANCASTER CLASSICS LIBRARY

Don's best early stuff at a bargain price. Includes the CMOS Cookbook, The TTL Cookbook, Active Filter Cookbook, PostScript video, Case Against Patents, Incredible Secret Money Machine II, and Hardware Hacker II reprints. **\$119.50**

### LOTS OF OTHER GOODIES

Ask the Guru I or II or III .....	\$24.50
Hardware Hacker II or III .....	\$24.50
The Case Against Patents .....	\$24.50
PostScript Beginner Stuff .....	\$39.50
PostScript Show and Tell .....	\$39.50
Intro to PostScript Video .....	\$39.50
PostScript Reference II .....	\$29.50
PostScript Tutorial/Cookbook .....	\$18.50
PostScript by Example .....	\$29.50
Understanding PS Programming .....	\$29.50
PostScript: A Visual Approach .....	\$22.50
PostScript Program Design .....	\$24.50
Thinking in PostScript .....	\$22.50
LaserWriter Reference .....	\$19.50
Type 1 Font Format .....	\$15.50
Acrobat Reference .....	\$24.50
Whole works (all PostScript) .....	\$350.00
PostScript Secrets Brochure .....	FREE
Hacking Secrets Brochure .....	FREE

### POSTSCRIPT SECRETS

A Book/Disk combination crammed full of free fonts, insider resources, utilities, publications, workarounds, fontgrabbing, more. For most any PostScript printer. Mac or PC format. **\$39.50**

### BOOK-ON-DEMAND PUB KIT

Ongoing details on Book-on-demand publishing, a new method of producing books only when and as ordered. Reprints, sources, samples. **\$39.50**

### BLATANT OPPORTUNIST I

The reprints from all Don's Midnight Engineering columns. Includes the case against patents, book on demand publishing, toner secrets, paradigm stalking, insider research, lots more. **\$24.50**

### RESOURCE BIN I

A complete collection of all Don's Nuts & Volts columns to date, including a new index and his master names and numbers list. **\$24.50**

### FREE SAMPLES

Well, nearly free anyway. Almost. Do join us on GENie PSRT to sample all of the Guru's goodies. The downloading cost on a typical Guru file is 21 cents. Modem access: (800) 638-8369, then a HHH. On prompt, XTX99005,SCRIPT.

FREE VOICE HELPLINE VISA/MC

**SYNERGETICS**  
Box 809-NV  
Thatcher, AZ 85552  
(602) 428-4073

Write in 146 on Reader Service Card.

## ON-LINE AND RELATED RESOURCES

**Adobe Systems Acrobat**  
1585 Charleston Road  
Mountain View, CA 94039  
(800) 833-6687

**America Online**  
8619 Westwood Center Drive  
Vienna, VA 22182  
(800) 827-6364

**CompuServe**  
5000 Arlington Center Blvd  
Columbus, OH 43220  
(800) 848-8199

**Dialog**  
3460 Hillview Avenue  
Palo Alto, CA 94304  
(415) 848-2700

**Electronics Now**  
500-B Bi-County Blvd  
Farmingdale, NY 11735  
(516) 293-3000

**GENie**  
401 N Washington Street  
Rockville, MD 20850  
(800) 638-9636

**Midnight Engineering**  
1700 Washington Avenue  
Rocky Ford, CO 81067  
(719) 254-4558

**Nuts & Volts**  
430 Princeland Court  
Corona, CA 91719  
(714) 371-8497

**PC Techniques**  
7721 E Gray Road #204  
Scottsdale, AZ 85260  
(602) 483-0192

**Synergetics**  
Box 809  
Thatcher, AZ 85552  
(602) 428-4073

**The WELL**  
27 Gate Five Road  
Sausalito, CA 94965  
(415) 332-4335

**Whole Earth Review**  
27 Gate Five Road  
Sausalito, CA 94965  
(415) 332-1716

several hundred dollars per year. Plus two dollars a minute typical connect time. They also now have a lot of info available on CD ROM. Plus all sorts of publication services.

They have a really great index and catalog. Free even. But you have to act as if you are *seriously* interested in a direct subscription before they agree to send you one.

### InterNet

*InterNet* or *Usenet* is the largest BBS in the world. This one started out as a federally funded ARPANET gateway for all UNIX users, especially teachers and researchers. Most of the original users get paid to participate through tax subsidies. Some carefully hidden, others quite obvious.

Anything can and will happen on Usenet. *Anarchy 101* reigns. The time from when someone decides to keep a secret until a vastly improved public domain version is Usenet revealed often gets measured in nanoseconds.

In several cases, the response time has clearly exceeded the speed of light. Ferinstance, every math freak in the world knew about the probable proof to the *Fermat's Last Theorem* less than five minutes after it happened.

Usenet has no sysop as such. Nor any central repository. Instead, each user can be a sysop if they want to. Some elect to ride herd on specific file collections or special interests.

At one time, Usenet was very hard to access. It was mostly by invitation only from sponsors that paid steep annual fees. Usenet gateways have recently been offered by all of the major online services. Including *GENie* and *CompuServe*. And also by high schools and colleges.

So, your private Usenet access is trivially easy to pick up today. Either free or, at the very least, without any surcharges. And several of the online services are now switching from plain gateways to total access setups.

There are now a dozen books out on navigating Usenet. Check those ads right here in *Nuts & Volts*, or any larger technical bookstore.

My own current Usenet address is SYNERGETICS@GENIE.GEIS.COM. My answers to most Usenet email are then posted at no charge to my *GENie* PSRT where they can best be shared. Response time averages an hour or so during normal use patterns. Private email answers are also available at my standard consulting rates.

I'm often asked why I don't make all my files available free on Usenet. Well, I don't slop at the public trough. I am an independent and a for-profit venture that has to see an underlying cash flow to continue. Exactly like the Safeway folks or those Purina Doggy Chow people.

### The Imminent Disaster

A major disaster of unprecedented proportions is now stalking InterNet. One that is certain to profoundly and dramatically alter Usenet forever.

At one time, Usenet was largely a closed club of tightly knit researchers, teachers, and similar academic types. The average user went far out of their way to contribute as much as they took. Caring and sharing were the watchwords for the day. If someone had a problem, you personally did what you could for them.

But all of a sudden, great hoards of unwashed masses have discovered the Usenet. *Newsweek*, talk radio, and

the feds, even. The number of users is now exploding at *twenty* percent per month. Fast and easy access links are now offered all over the place. Most community colleges and many high schools now have an InterNet access. Anyone who wants to get on Internet can now do so. Cheaply or even free.

Most of the new users are a totally different breed of animal. Some of them are *lurkers* who steal all they can but never contribute. Others are those *flamers* who go out of their way to be obnoxious troublemakers. Yet others are "free email" scamming refugees from the *Prodigy* debacle. Still others are junk mail marketing pros.

Your bottom line is this: The few people still paying for the Usenet are vastly different than the many people now using it for free. The new users are literally choking the network to death. And it is going to get worse.

No way can it continue.

I don't have an answer to this. I suspect what will happen is that some of the original Usenet people will start up *Usenet II* with a highly restrictive access which once again restores the original caring and sharing scholarly environment. Perhaps by demanding UNIX-only compression schemes to keep out the riff raff.

Stay tuned on this one.

### GENie

Your three best commercial online services are *CompuServe*, *GENie*, and *America Online*. Because I am a *GENie* sysop, I tend to be biased here.

CompuServe is the largest while America Online is the friendliest. But *GENie* is widely regarded as having the most and the finest of technical downloads in their library files. *GENie* is also the lowest cost service. At last count, something like 135,000 library files are now available on *GENie*.

All three services have hundreds or even thousands of local call numbers across the country. So they are likely to be a local call away for you. *GENie* usually costs \$3 per hour, starting off with an \$8 per month flat fee which gives you four free hours.

Besides all their shopping services, email and the Usenet gateway, *GENie* now offers many hundreds of special *RoundTables*. Each of these will often include a news feature, some direct user-to-user message system, special online group conferences, and an extensive download library.

Of the many *GENie* RoundTables, try IBM for PC, MAC for Mac, and A2

or A2.PRO for you Apple II folks. The RADIO board has thousands of library files. Especially for ham radio info and other hobby comm.

And there's hundreds more where these came from. Everything from pet advice to airline schedules to science fiction to stock quotes.

My own portion of *GENie* is called PSRT. Short for *PostScript RoundTable*. We've now got a thousand files up that include all of the latest and best on PostScript. Which is by far the best Hacker's universal general computing language, anytime, ever. We also offer a unique forum for *Book-on-demand* publishing and assistance to anyone who wants to cheaply send device independent camera-ready copy out to anyone anywhere.

We also do provide special reader services for *Nuts & Volts*, *Midnight Engineering*, *Electronics Now*, and *PC Techniques* magazines. I also do stock online reprints of most of my *Resource Bin*, *Blatant Opportunist*, *Hardware Hacker*, *Ask the Guru*, and other stories. Plus ap notes and tutorials not offered elsewhere. And once again, available device independently and full camera ready at an average downloading cost of *twenty one* cents each.

*GENie* provides an *Alladin* scripting supervisor free for the downloading. *Alladin* can greatly reduce your costs. This can automatically call up in the middle of the night, grab your email, check into selected RoundTables, or even download programs and other library files. A number of new *GENie* graphic interfaces are now available, but they are admittedly still weak in this crucial area.

For a free brochure, give them a call at (800) 638-9636. For online access, use the info in the end blurb below.

### The Well

One of my favorite west coast BBS resources is *The Well*. Sysoped by the people who publish the *Whole Earth Review*. You'll find lots here on new age topics, small-is-beautiful, home power, alternate energy, and holistic topics. An unusual BBS for sure. But a very well done one.

These folks are a very important resource and certainly deserve your support. Give them a try.

### Your Own BBS?

Starting your own BBS is probably *not* a good idea. Most people grossly underestimate all of the time and the effort required and the quantity of

hardware and software that has to be tied up. And obscenely overestimate just how many users will call for how long or how often.

Figure a bare minimum of *twenty* hours per week for each sysop. And that's slicing it *mighty* thin.

Most of the big BBS services offer free local calls nationwide. So it will cost your average national user *more* to call your "free" board than using a commercial service. And hourly long distance phone rates are *much* higher than typical commercial BBS charges. Alternatives such as the *Fidonet* have their own limitations.

With many thousands of bulletin boards currently active, your chances are overwhelming that more info and better info is already on-line.

If your board is typical, you can plan on getting *one* upload for each 2000 downloads. Unless you offer an extremely special interest, an absolute minimum of one thousand downloads in your library is essential.

Very few people actually buy stuff online. This simply does not happen. Ferinstance, my *GENie* PSRT is now up to 50,000 library downloads spread over one thousand files. Not half bad. Most of these files do include one or more hard sells for all my *Synergetics* stuff. The total direct email sales these generate? Less than *one* per week.

Not to mention that picking up a VISA or *MasterCard* merchant status for telephone or direct mail orders is still very hard to do in most parts of the country. Or that some BBS comm software is easily tampered with by outsiders. Or that others might use your service for different purposes than you first intended. Especially for junk mail, file transfers, or free email mass distribution.

Or that you could conceivably be held legally liable for any postings that anyone takes an exception to.

Alternates to your own board are becoming a sysop for someone else. Or offering your information over the InterNet. If you do have access to a specialized resource, the chances are fairly good that one of the commercial online services might be interested in working with you. Besides paying you as much as twenty to thirty cents an hour, the commercial services offer such perks as unlimited free access to everything else online. Plus valuable networking contacts.

Nonetheless, if your main goal is something other than making money via direct email sales, your own BBS

may be an interesting thing to do. If it fills local needs. Especially if you can charge local sponsors to prepay for board services. Say ten bucks a month to carry all of the activities of a local church or club. Or school menus and special events. Say twenty bucks per month to offer reviews of all videos a local rent-a-flick has in stock.

The rules here for success are to (1) Keep it local; (2) Seek out sponsors; (3) Fill lots of urgent community needs; (4) Don't expect much in the way of direct sales, and (5) Offer dozens (and preferably hundreds) of services.

There are national franchises that sell computer work-at-home schemes that involve email. These can end up quite expensive and the cash flows may be overstated.

As always, look before you leap. And talk to others about them.

Much more on starting your own ventures of this type appears in my newly revised *Incredible Secret Money Machine II*.

### This Month's Contest

Let's have a pair of contests for this month. First, put me on to any cheap sources for all the stuff *Dialog* offers. Most especially *Inspec*, *MathSci*, and *Compendex*. And all the library stuff such as *Books in Print*, *Encyclopedia of Associations*, and *Uhlricht's Periodicals Dictionary*.

Or simply tell me about any other unusual online resource that I may not know about.

There will be a large pile of my new *Incredible Secret Money Machine II* books going to the dozen or so better entries, plus an all-expense-paid (FOB Thatcher, AZ) *tinaja quest* for two that will go to the very best of all.

Let's hear from you. ♦

---

*Microcomputer pioneer and guru Don Lancaster is the author of 30 books and countless tech articles. Don maintains his no-charge tech helpline found at (602) 428-4073, besides offering all of his own books, reprints, and all of his consulting services. He also has a free brochure full of his resource secrets waiting for you. Your best calling times are 8-5 on weekdays, Mountain Standard Time.*

*Don is now the sysop of GENie PSRT, where a special Resource Bin topic has been reserved for Nuts & Volts readers. For fast modem access, use (800) 638-8369 and enter HHH. When prompted, enter XTX99005.SCRIPT.*

*You can also reach Don at Synergetics, Box 809, Thatcher, AZ 85552.*

# Stalking The Wild Paradigm

I've recently gone over dozens of my successful hardware hacking projects and hundreds of my big failures over several decades, trying to fathom what worked and what did not. I am convinced that one of the crucial underlying secrets is watching for and then profiting from *paradigm shifts*.

A *paradigm* is just the way people perceive things to be. And a *paradigm shift* occurs whenever someone upsets the apple cart. Which might happen whenever any vastly new or different way of doing things becomes obvious. Or something becomes much cheaper or more widely available.

In general, hardware hacking does not do well in the "business as usual" times. It is only when some sudden and dramatic change or other fundamental shift in values takes place that all of the new opportunities emerge.

Some ancient personal examples of paradigm shifts: The low cost silicon controlled rectifiers which blasted the thyatron out of the saddle and opened up psychedelic lighting. The triacs that made light dimmers and power tool speed controls possible. RTL digital integrated circuits that revolutionized counting and digital logic.

Low cost nickel-a-bit shift registers and character generators which permitted my *TV Typewriter* (RE Sept 73) as the opening round fired in the personal computer revolution. The simple active filters developed by theoretical types totally unable to communicate either coherently or intelligently.

Price reductions in CMOS chips. The 6502. The KIM-1 microcomputer. De-mathifying all the pseudorandom sequence generators. The Apple IIe. The monumental new stupidities now hopelessly crippling all of traditional publishing. CD ROM. That insanely great PostScript language. Or the latest stunning wavelet breakthroughs.

Your key hacker opportunity: *The people who are doing the shifting of the paradigm usually do not have the slightest notion what they are doing, since they will always be rearwardly focusing on the way things were.*

When a paradigm shifts, all sorts of new hardware hacking opportunities immediately open up. Especially if you are able to view things from a different perspective. Or can reduce the cost of something by 50:1, totally changing the markets to something utterly foreign (and totally misunderstood) by "them" and the way things were.

## Dealing With Shifts

We can identify three obvious cases here. In the first, a

paradigm shift does not take place and things remain pretty much the way they were. We can call this the *Business as Usual*, or the BAU case, and not very friendly to *Midnight Engineers*. Not in the least.

In the second, a paradigm shift takes place but you try to ignore it. This is the *Sucker Bet*, and, if you give it half a chance, it will eat you alive.

Finally, a paradigm shift can take place and you might be one of the first to take full advantage of it within a *Midnight Engineering* context. We'll call this one a *GoFer*, as in *Go For It*. This is the one you should seek out.

Let's pick up a few more details on these three paradigm shift cases...

## Business As Usual

*Business as usual* takes place in the absence of a paradigm shift. Leaving the *status quo* right where it is. In BAU instances, there is simply not much opportunity for *Midnight Engineers*. And to think otherwise can cause you grief. Let's look at an example or two of some typical BAU's which are best avoided. At least for now.

A few decades back, *Peltier coolers* sounded like a wonderful deal. Small, compact, and potentially cheap solid state modules. You input electricity and one side gets cool to super cold, acting as a compact heat pump with no moving parts. But the big gotcha is that these end up horrendously inefficient. Since these have less than 1/50th the efficiency of most conventional freon refrigeration, they make the Faustian bargain with you "Yes, I'll cool it, but first you have to build a humongous bonfire in precisely the wrong place."

With a typical cooler, to pump one watt of heat, you have to get rid of an additional six more. Thus the "coolers" can

easily end up heating instead, should your hot side temperature gradient to ambient get out of hand.

Assuming no paradigm shifts in the last week or two, there has not been one iota of improvement

in Peltier coolers in the past two decades. The very same devices sold then are sold today. Yes, Peltier modules do solve some very arcane problems in unique ways. Things like microscope slide chillers, in dew point instrumentation, satellite thermal management, and for infrared imaging coolers. Places where tiny amounts of heat are involved and where superinsulation and an absolute thermal control is possible.

**A paradigm shift occurs when someone upsets the apple cart, opening up new hacking opportunities.**

But forget using these to make ice cubes or to keep a picnic cooler cold. They simply won't hack it. Most good uses for these devices have been thunk up long ago. And most were economic failures. Several times over.

Alternate typewriter keyboards. The old QWERTY keyboard was originally designed specifically to *slow typists down*. Most totally random keyboards perform far better than QWERTY. The Dvorak keyboard only will move your fingers 1/20th as far at a considerably higher speed. But Dvorak is one dog that flat out will not hunt. QWERTY is too deeply culturally ingrained.

As a ferinstance, the Apple IIGS computer lets you instantly shift to a Dvorak keyboard with a few mouse clicks. The number of IIGS curiosity seekers that tried Dvorak for fifteen seconds and agreed that it was faster and better: Lots. The number of those that still use Dvorak today: Zero.

Deep cultural ingraining can be far more subtle. Why don't we see more touch screens? And why has the touch screen technology not improved much in the past ten years, while mice and trackballs really took off? I think the simple answer is that people do not want to touch computer screens. And if you try to make them do so, it probably will cost you time, money, and market share. I'd guess this has something to do with "Don't ever touch your eyes", "Don't go up to the screen at the movie theater", or "Keep your peanut butter and jelly fingers off that tv faceplate." Creeping Momism, fer sure. But it is definitely and unquestionably there.

BAU also takes place if you assume a market is larger or less fragmented than it really is. For instance, anything electronic that is "good for" the photo market is almost certainly doomed to failure. Timers for rodeos or sports events are other examples of extremely specialized one-on-one sorts of things. Lower priced logic analyzers probably have zero market. Those swift enough to know what a logic analyzer is are probably working for a firm that can afford a name brand biggie instrument; the rest don't have the slightest idea what you are talking about.

Unless a paradigm shifts. If you can pick up a new and better way of doing it, then go for it. But avoid any BAU situations unless you do know *exactly* what you are getting into.

### Avoiding Sucker Bets

A *sucker bet* happens whenever a paradigm clearly shifts and yet that shift remains intentionally ignored. This usually happens whenever a large and slow-to-react megafirm continues to try and force an ancient, inferior and second-rate product into any new or rapidly changing market. Millions of dollars have been and continue to be lost on sucker bets. Especially when not-invented-here is a big factor.

As a *Midnight Engineer*, should you involve yourself in any manner with these has-beens, you are almost certain to lose out in the long run. Your own selection of the sucker bets probably differs from mine, but let's take a quick look here into several of the more blatantly obvious sucker bets that I personally have decided to avoid...

*UNIX*, of course. It was a dumb idea when the telephone company decided it was good for me two decades ago, and it certainly hasn't improved any with age. Yet hundreds of

millions of corporate dollars have been poured down this obvious rathole. With no visible effect. A computer operating system succeeds because individuals make one-on-one decisions that any chosen operating system is a compact and personally useful convivial tool. Not because it gives the meglomaniac standards committees lots of reasons to ceaselessly argue with each other over why a bloated corpse smells bad. The only thing that could save UNIX at this late date would be some \$30 shareware version that can run on an unexpanded *Commodore 64*.

*The NeXT Computer*. Whenever any product is first created, certain design goals seem favored at the expense of others. A case can be made that two primary design goals for the *NeXT* machine did appear to be *revenge* and *spite*. Which could form the core to a logical explanation as to just why such monumental technical and marketing blunders were ineptly committed on this machine. Blunders totally obvious to most any computer-literate seventh grader. The question that sorely needs asked here – Is the Emperor wearing any clothes?

*DVI Video Animation Compaction*. It was ancient, overblown, and klutzy when RCA blatantly overpromoted it, and even more dated when *Intel* picked it up on the junk table at a yard sale. Four generations of technology have completely trampled this hoary beast. The software DCT (or Discrete Cosine Transform), which got superseded by the low cost hardware DCT chips. Both instantly available cheaply to the end user. And both of whom are about to get shot clear out of the saddle by the Wavelet Mafia, who are coming on like Gangbusters. And it is an even bet today that Barnsley and crew could end up having their fractal compression ultimately being the big winner in the animation and HDTV sweeps.

*PostScript Imitators and hangers-on*. One thing the not-invented-here boys have yet to learn: PostScript flat out ain't broke! In fact, this is probably by far the most unbroke thing in all of computerdom today. And the reasons are simple. Besides being a completely device independent method of mixing high quality text and high resolution graphics, PostScript is a powerful and completely general purpose computer language that can hold its own against any modern challenger. Even more important, genuine PostScript feels right from the instant you first use it. Those vibes are overwhelming. PCL should have been flushed when the Babylonians upgraded to Cuniform on clay tablets. And the TrueType fiasco is not even wrong.

*Teletext*. The end-user desirability of most Teletext services seems to lie somewhere between Herpes and AIDS. There are two main telecomm models active today. The Teletext, or *dictator* model says "You shall consume what we decide is good for you when and how we tell you to, on our special, outrageously expensive, and stupidly encrypted one-way hardware; and you will pay us through the nose for this privilege. Otherwise, you shall sit down and shut up." The UseNet or *anarchist* model says "We would like to serve as your two-way information broker. We will be happy to help you link your favorite computer setup to any and all of the worldwide telecomm resources on any basis that you feel appropriate." The supreme irony, of course, is that the two-way anarchist model is far cheaper to the end user and infinitely more powerful than the dictator model.

---

Among all the leading information utilities, *CompuServe* and *GEnie* do lean towards the anarchist model, while most of the out-of-tune managerial befuddlement and end user outrage of *Prodigy* could be directly traced to its TeleText heritage.

### Some GoFers

A GoFer is some situation where a paradigm has clearly shifted and others have yet to take advantage of that shift in a big or mainstream way. Herein is where the main *Midnight Engineering* opportunities lie. We've looked at lots of GoFer opportunities in past *Blatant Opportunist* columns and the primary focus of these diatribes will continue to be trying to pin down any developable new opportunities.

To refresh your memory, a few of the *Blatant Opportunist* GoFers that we have already looked at now do include Book-on-demand publishing, direct toner printed circuits, low pressure pneumatics, magnetic refrigeration, visible laser diodes, Navicubes, Santa Claus machines, low cost waterknives, Dildonics, shared SCSI comm, toner cartridge reloading, induction motor speed controls, and desktop finishing opportunities. And my GoFer for this week has to be *Wavelet Theory*, whose spread is explosive. There is no area of computerdom or electronics that will not be impacted by wavelets.

More info on GoFers appears in our back *Midnight Engineering* columns, in my *Blatant Opportunist* reprints, and in my PSRT uploads on *GEnie* (800) 638-9636. We'll continue to explore all of these and other GoFers in future columns. But for now, try to identify which paradigms that you can relate to are shifting in exactly what way.

---

*Microcomputer pioneer and guru Don Lancaster is the author of 26 books and countless articles. Don now maintains a no-charge technical helpline you will find at (602) 428-4073, besides offering all of his own books, reprints, and various services. He also has a free brochure chock full of his new insider hardware hacking secrets waiting just for you. Your best calling times are 8-5 on weekdays, Mountain Standard Time. Or you can reach Don by way of his Synergetics, at Box 809, Thatcher, AZ 85552.*





by Don Lancaster

# Emerging Technologies

**M**any times in the past, I have managed to make a buck or two through second guessing which of the new technological breakthroughs are about to become really big winners. What you want to watch for is something that is soon to get dramatically cheaper or ridiculously better. Preferably a something that can be beat out on a brick in your backyard.

Then, you nudge things along by high profile offering the emerging idea or product *directly* to an entirely new group of end users at one-tenth of the going price or less. A direct mail kit linked to a construction project in a hobby or tech magazine is often a very good way to accomplish this.

As I see it, there are some excellent candidate technologies today crying to be used. Let's round up a few of these and see if you can relate to any of them. I'll also try and show you where to go for more info. Besides the *Names and Numbers* sidebar included here, you will find more detail through my *Hardware Hacker* reprints.

## Visible Laser Diodes

The traditional gas laser people have had nearly three decades to get their collective act together, and they have failed miserably. They are now about to be completely shot out of the saddle by visible red laser diodes.

Compared to helium neon gas lasers, these new visible laser diodes are far cheaper; vastly more efficient; much smaller; last many times longer, are insanely more rugged; can easily get run from a penlight cell or two; and modulate simply and linearly.

While prototype diodes are still in the \$80 range, production quantities in a year or two should be well under \$5 each. Besides a diode, you will need some simple optics called a *collimating pen*, and a feedback regulator.

Leaders in the field include *Sharp*, *Toshiba*, and *Phillips*. Trade journals are the *Laser Focus World*, *Photonics Spectra*, and *Lasers and Optronics*. A pair of surplus sources are *Meredith Instruments* and *MWK Industries*.

## Low Pressure Pneumatics

I continue to be amazed that there is a thirty cent three-way pneumatic air valve on the surplus market that has gone undiscovered and unused by you hackers for nearly twenty years now. It is called a TCS or a SCS valve, and is short for a *Transmission Controlled Spark* or *Speed Controlled Spark*.

Low pressure pneumatics in the 3 to 5 PSI range has several outstanding advantages. First and foremost, air can amplify. Most of your force can come from a cheap aquarium pump or even a truck tire. Several milliwatts at

your valve controls many tens of watts.

Air goes around corners quite well, especially robotic elbows. Your air actuators can be very linear, compared to the extreme nonlinearity you get with a solenoid. Air systems are also explosion proof, low noise, and shock free. The millisecond response times can be better than mechanical stuff.

One key secret I've learned with low pressure pneumatics is to *never have a seal that moves*. Thus, your best types of actuators will be balloons, rolling diaphragms, or bellows shaped devices. You will also want a regulator and a small accumulator (A toilet bowl tank float works fine) between your pump and the rest of your pneumatics.

Surplus sources for the TCS valves, as originally manufactured by *Carter Carburetor*, include *Edmund Scientific*, *C&H Sales*, *Jerryco*, or your local junkyard. Try *Hygenic Manufacturing* for cheap tubing, and *Value Plastics* for low cost connectors. As a very off-the-wall source, the *Player Piano Company* stocks all sorts of unusual tools and techniques. Both *Sprague* and *SGS* do offer useful computer interface power drivers. The *Clippard Minimatic* people are good for ideas, but their stuff costs too much.

## Direct Toner Printed Circuits

There is absolutely no reason whatsoever why any one-of-a-kind printed circuit prototype should take you more than seven minutes or cost you more than fifty cents. It's certainly nothing you would want to send out for or pay somebody else to do.

These days, the layout portion of your pc prototyping is utterly trivial, thanks to the new PostScript language, which totally blows away all of the earlier circuit layout methods.

But what is not well known is that toner makes an excellent etch resist. *Xerox* proved this in the mid-sixties when they foisted off zillions of arcanelly ancient copy machines onto unsuspecting aerospace companies as

instant pc prototyping machines.

Today, we are in a "pretty nigh but not plumb" situation involving reliably getting toner on a board. Sometimes you win and sometimes you lose.

What is needed is some specially formulated toner; one magic transfer sheet that is dimensionally stable at high temperatures and only loosely holds toner; and a *Kroy Color* style laminating machine that reliably transfers the

**Watch for something that is soon to get dramatically cheaper or ridiculously better.**

toner to the pc board. Or else a laser printer modified to print directly onto 1/16th inch copper clad.

I've found that a few seconds of pre-etch helps bunches, as does preheating the board so it does not act as a giant heat sink. A post-transfer bake also helps. Trying to use an ordinary iron is an outright joke.

I currently use a *Kapton* film from *Dupont* that I've coated with a high temperature mold release from *Miller-Stephenson*. A commercial toner transfer product called *Meadowlake* works for some people some of the time. Fake *Kroy Color* machines and toners are found at *Lazer Products*. Two other toner sources are *Black Lightning* and *Don Thompson*.

Two fine trade journals on printed circuits are *Circuits Manufacturing* and *Electronic Packaging and Production*, while your best hacker source for pc boards and etchants is *Kepto*. A low price, low end printed circuit layout package is included in my *PostScript Show and Tell* from *Synergetics*.

### The Navicube

What the world really needs is a good \$10 inertial navigation system. And it is only a matter of time before some kids in a garage or a Korean toy designer comes up with one. One thing for sure – it certainly will not be any existing aerospace supplier!

I visualize the *Navicube* as a three inch cube that always knows exactly where it is and which way it is pointed. Either on an absolute basis or since it was last reset.

Among its zillions of other uses, you could map a cave by putting one of these in a ball and bouncing it off the walls and ceiling. Or, to show someone where you live, just reset and then mail the Navicube to them. When all three readouts are zero, they've found you.

The dramatic drop in the price of precision accelerometers makes the Navicube possible. Chips, design data, and ap notes are available from *NovaSensor*, *SenSym*, or *IC Sensors*.

Since the error of an accelerometer goes up as time squared, you'd want to back these up with a cheap laser gyroscope or some GPS position info.

### Radial Arm Waterknives

One of the more obvious properties of a 65,000 PSI water stream is that it doesn't pay much attention to anything you put in front of it. Thus a waterknife can cut just about anything. Cheaply, coolly, cleanly. And distortionless.

One of the better done waterknife demos consists of a large and gooey chocolate cake sitting on a two inch thick slab of high strength steel. The waterknife cleanly chops on through both of them at the same time.

Unfortunately, most waterknives are being built by the wrong people for the wrong markets, so these are priced in the \$80,000 to \$200,000 range.

Instead, what we really need is a \$300 home shop radial arm waterknife. Besides all of that usual artsy-craftsy stuff, you could use this for precision woodworking, dressmaking, for pizza slicing, ice carving, paper trimming, gopher control, fudge making, or even for lawn edging.

The top waterknife manufacturer is *Flow International*, while *Haskel* is one source of the oil-over-air high pressure pumps normally used. Additional info on waterknives and

## EMERGING TECHNOLOGIES NAMES AND NUMBERS

**Adobe PostScript**  
1585 Charleston Road  
Mountain View, CA 94039  
(415) 961-4400

**Black Lightning**  
RR 1-87 Depot Road  
Hartland, VT 05048  
(800) BLACK99

**C & H Sales**  
Box 5356  
Pasadena, CA 91107  
(800) 325-9465

**Carter Carburetor**  
9666 Olive Road  
St. Louis, MO 63132  
(314) 997-7400

**Clippard Minimatic**  
7390 Colerain Road  
Cincinnati, OH 45239  
(513) 521-4261

**Dialog Information Service**  
3460 Hillview Avenue  
Palo Alto, CA 94304  
(415) 858-2700

**DTM Systems**  
1611 Headway Circle, B2  
Austin, TX 78754  
(512) 339-2922

**Dupont Kapton**  
1007 Market Street  
Wilmington, DE 19898  
(302) 774-1000

**Edmund Scientific**  
101 East Gloucester Pike  
Barrington, NJ 08007  
(609) 573-6250

**Exair**  
1250 Century Circle North  
Cincinnati, OH 45246  
(513) 671-3322

**Flow International**  
21440 68th Avenue South  
Kent, WA 98032  
(206) 872-4900

**Haskell**  
100 East Graham Place  
Burbank, CA 91502  
(818) 843-4000

**Hygenic Manufacturing**  
1245 Home Avenue  
Akron, OH 44310  
(216) 633-8460

**Jerryco**  
601 Linden Place  
Evanston, IL 60202  
(312) 475-8440

**Kepto**  
630 Axminster Drive  
Fenton, MO 63026  
(314) 343-1630

**Kroy Sign Systems**  
14555 North Hayden Road  
Scottsdale, AZ 85260  
(800) 521-4997

**Lazer Products**  
12741 East Caley #130  
Englewood, CO 80155  
(303) 792-5277

**MasterCAM**  
2101 Jericho Turnpike  
New Hyde Park, NY 11040  
(516) 328-3970

**Meadowlake**  
25 Blanchard Drive  
Northport, NY 11768  
(516) 757-3385

**Meredith Instrument**  
6401 North 59th Avenue  
Glendale, AZ 85301  
(602) 934-9387

**Miller-Stephenson**  
George Washington Hwy  
Danbury, CT 06810  
(203) 743-4447

**MWK Industries**  
1440 S. College Blvd #3B  
Anaheim, CA 92806  
(800) 356-7714

**Phillips**  
2001 W Blue Heron Blvd  
Riviera Beach, FL 33404  
(407) 881-3200

**Player Piano Co**  
704 East Douglas  
Wichita, KS 67202  
(316) 263-3241

**Roland Digital**  
7200 Dominion Circle  
Los Angeles, CA 90040  
(213) 685-5141

**SGS-Thompson**  
1000 East Bell Road  
Phoenix, AZ 85022  
(602) 867-6259

**Sharp**  
Sharp Plaza  
Mahwah, NJ 07430  
(201) 529-8757

**Sprague**  
70 Pembroke Road  
Concord, NH 03301  
(603) 224-1961

**Synergetics**  
Box 809  
Thatcher, AZ 85552  
(602) 428-4073

**Technical Insights**  
PO Box 1304  
Fort Lee, NJ 07024  
(201) 568-4744

**Don Thompson**  
23072 Lake Center #100  
El Toro, CA 92630  
(714) 855-3838

**3-D Systems**  
26081 Avenue Hall  
Valencia, CA 91355  
(805) 295-5600

**Toshiba**  
1220 Midas Way  
Sunnyvale, CA 94086  
(800) 321-1718

**Value Plastics**  
3350 Eastbrook Drive  
Fort Collins, CO 80525  
(303) 233-8306

**Vortec**  
10125 Carver Road  
Cincinnati, OH 45242  
(800) 441-7475

**Whole Earth Review**  
27 Gate Five Road  
Sausalito, CA 94964  
(415) 332-1716

---

all their suppliers often appears in *Machine Design* and *Design News* magazines.

### Magnetic Refrigeration

Solid state cooling using the *Peltier* effect is dead in the water, owing to its ludicrously low efficiency. And all the regular mechanical air conditioners are now scrambling to come up with some acceptable Freon substitute.

While no-moving-parts air vortex coolers, such as those from *Vortec* or *Exair*, certainly are cute, can get super cold, and seem to blatantly defy the laws of thermodynamics (they don't really), these are limited in what they can do and where they can be used.

But I just got wind of a brand new way of cooling things that just might run away with a rather large bag of marbles. This is a *Magnetic Refrigeration*, using the *magnetocaloric effect*. Apparently certain materials heat in the presence of a magnetic field and release that heat otherwise.

Figures such as a 40 times efficiency improvement and much lower costs than traditional mechanical systems have been bandied about. While lots of the excitement currently centers on ultra-low temperatures, apparently the effect is usable for ordinary air conditioning and heat pumps as well. One material involved is Gadolinium.

I haven't had time to chase this one down fully. An obvious starting point is the *Dialog Information Service*. But stay tuned. An expensive "executive" report on this emerging field, is now available from *Technical Insights*.

### Dildonics

*Virtual Reality* is an oxymoron that has already been ground into dust by far too many marketing sleezoids. I much prefer the more accurate and more honest *Dildonics* term.

What you have here is one super simulator that combines a total visual display, power gloves, a treadmill, and tactile sensors or whatever to create a controlled artificial environment.

Besides the obvious uses involving mind-blowing interactive multi-person video gaming and advanced military flight simulators, Dildonics is already being used today for such things as an architectural client "walk through" of a future building mockup. Ultimately, Dildonics will impact everything from model railroading to microprocessor controlled party dolls. Although I can foresee some quite interesting product liability suits involving programming glitches on the latter.

A good summary of Dildonics has appeared in the Summer 1990 *Whole Earth Review* on pages 80-87. Other useful resources include the *Computer Graphics Review* plus the *Advanced Imaging* trade journals, as well as the yearly *Siggraph* graphics shows.

### Santa Claus Machines

The science fiction authors have had them for years, but we are just starting to see expensive and primitive versions of Santa Claus Machines showing up today. Another name for this emerging field is *desktop prototyping*.

What you have here is any scheme to quickly and cheaply convert any word processor file into a three dimensional solid object. You can use the object as is, or else use it as a mold or lost-wax casting for conversion.

The intent here is to create your prototypes in minutes rather than in months, and for pennies instead of tens of thousands of dollars. The only little problem is that the current machines are obscenely overpriced. There is no reason why any Santa Claus machine should have to cost over \$200.

While many methods are emerging, the three most prominent at the present time are *direct machining*, *stereo lithography*, and *powder sintering*.

Direct machining simply uses some small stepper-motor controlled lathe or milling machine. Two pricey sources are *MasterCAM* and *Roland Digital*. Several others advertise in *Industrial Education* and *School Shop*.

Stereo lithography takes a tank of a liquid uv-curing photopolymer and then uses a laser beam to selectively harden a solid object out of it. The leader here is *3-D Systems*.

Powder sintering makes a lot more sense to me than the use of uv-curing photopolymers. You spread out a thin layer of a sinterable plastic or wax granules. Then you selectively laser heat the granules to fuse them together. Drop the assembly a tad, and repeat the process layer by layer. One pioneer in this new field is *DTM Systems*.

Besides shattering the cost barriers on Santa Claus machines, there's all sorts of opportunities here involving new service bureaus that rent instant prototyping time on existing machines. Oppornockity tunes but once.

### Brain Parity

Depending upon who is doing the counting, the human brain contains from 4 to 35 billion neurons. Putting this into perspective, we are talking around ten CD ROM disks here, or perhaps a dozen of the 256 Meg x 17 SIMM strips which several Japanese manufacturers have already committed to a 1997 volume production.

And, no, I don't buy this bull that we don't have the algorithms yet. If the electronic memory is big enough and fast enough and cheap enough, all else inevitably will follow.

Thus, within one decade, machines will definitely be smarter than people. Which should create changes more profound than the agricultural revolution or the first industrial revolution. Yet, everyone appears to be either ignoring this near term inevitability or outright denying it.

Possibly they will keep us around for a while as pets, but I'd guess that they will tire of us rather quickly. So much for the opposable thumb. Sigh.

I'm not too sure just how to tap this inevitability and profit from it. Surely one prerequisite is keeping informed. One source for the memory and neuron computing happenings is *E.E. Times*. See *Uhlrichts Periodicals Dictionary* for this and all the other trade journals I've mentioned here. ♦

---

*Microcomputer pioneer and guru Don Lancaster is the author of 26 books and countless articles. Don now maintains a no-charge technical helpline you will find at (602) 428-4073, besides offering all of his own books, reprints, and various services. He also has a free brochure chock full of his new insider desktop publishing secrets waiting just for you. Your best calling times are 8-5 on weekdays, Mountain Standard Time.*



by Don Lancaster

# Emerging Technologies II

**W**ay back in *Blatant Opportunist #4*, we checked into several emerging and highly hackable new opportunities. Stuff which was developable on a small scale, which did not go up against any heavy duty competition, had the correct overall vibes, and was sitting smack dab upon some technical, paradigm, or economic breakpoint on its curve.

Looking back, most of my predictions turned out to be right on. As to some others, well, just give them a while longer to develop.

For this time around, I thought I'd throw several new happenings onto the pile. Stuff that's come up in the two intervening years. Stuff that I am certainly going to be taking a very close look at. And stuff that potentially offers exciting new *Midnight Engineering* opportunities...

## Dye Based Solar Electricity

Silicon solar cells have pretty much had it. They just don't know it yet. The largest solar cell power plant in the country has recently been torn down and sold to hackers at a yard sale. They found they could make more money by selling off surplus parts to hobbyists than they could by generating any electrical power. *Surplus Traders* is one of many sources for the leftovers.

Sadly, most US solar cell producers have been acquired by major oil companies and then meticulously smothered under three layers of bumblingly incompetent middle management.

There are several inherent flaws in silicon solar cells. Silicon is ultra hard, very brittle, and highly opaque. But worst of all, it only accepts energy in discrete "one size fits all" energy packets. At one near-infrared light frequency, the packets are precisely the right size for a fairly efficient conversion. Lower frequencies become waste heat, and any "spare change" above the key packet size for higher frequencies is also blown as waste heat. As a result, the best theoretical sunlight efficiency you could even hope for in a silicon cell is 26 percent. Real cells come nowhere near this figure. And high efficiency is crucial for economic solar power.

The only tiny little thing that silicon cells had going for them was that they were better than anything else. But this may be changing in a really big hurry, thanks to a newly emerging *dye based solar* technology.

If the sun was a radio star, you would simply build an antenna and a rectifier. Efficient power conversion would be yours. The technology needed is ancient and almost trivial. In fact, you would call it a *crystal set*.

Until recently, it has not been at all obvious how to build

optical antennas and rectifiers. One earlier attempt known as *Lumeloid* films by *Advanced Research & Development* used microlithography to position submicron antennas and metal barrier diodes on glass.

But it turns out that certain organic dyes can act both as efficient antennas and rectifiers. These dyes are related to those involved in plant photosynthesis. The big difference is that the dyes only raise energy levels of their electrons, while the plants use the raised energy for organic reactions that make cellulose, sugars, and other tasty stuff.

One key paper on dye solar methods is found in the 1990 *International New Energy Technology Symposium* run by the *Planetary Association for Clean Energy*. And two more appear in the October 24, 1991 issue of *Nature*.

A pair of wildly different magazines on solar power use are *Home Power* and the *EPRI Journal*. I've got lots more solar info in my *GENIE* PSRT files #320 HACK46.TXT, in #373 HACK49.TXT and #434 HACK53.TXT, and in my new *Hardware Hacker III* hard copy reprints.

## Wavelets

There's a genuine revolution coming down in applied mathematics, centered on *Wavelet Theory*. A revolution that's having a stunning impact on virtually *all* engineering subjects. From cardiology through seismography. From

animal vision through side looking radar. From video compression up through radio spectrum analyzers. From holograms through digital signal processing.

Until now, all of these topics had one big thing in common: To perform any

useful analysis or advanced development, you had to use *Fourier Analysis*, an ancient tool that everybody hates.

Traditionally, Fourier let you transform the *time domain* into the *frequency domain*. For instance, a square wave will bounce up and down against time, while it will consist of a string of odd harmonics with respect to frequency.

Fourier analysis has several major problems that the wavelets can avoid. Fourier is a "take-it-or-leave-it" sort of *linear* tool. Change anything and you change everything. And the edges of your analysis (called windowing) need special treatment. Wavelets instead behave as a *log* tool which lets you analyze on a global *and* a local basis.

Video compression is an important new wavelet app, especially for HDTV. Compared to the klutzy and primitive JPEG and MPEG schemes, wavelets offer simpler and more standard circuits, better results, and zero "tiling" artifacts.

**The largest solar cell power plant in the US has recently been torn down and sold to hackers at a yard sale.**

Wavelets also can let you work on the big lumps first, quickly giving you a lesser resolution image and adding detail when and as needed. Which gets quite important in animated video and rapid movie scene changes.

To become wavelet literate, start with those intros in *Science* for August 24, 1990, and *EE Times* for November 5, 1990. Then go on to the tutorials in *IEEE SP* magazine for October of 1991, and *Dr. Dobbs Journal* for April of 1992. The definitive book is *Wavelets and Their Applications*, published by Jones and Bartlett (617) 482-3900.

The folks at *Aware Inc.* (617) 577-1700 do have *Wavelet Explorer* software and several free reprints. I have also posted some IBM wavelet shareware to *GENIE* PSRT as file #365 WAVELET.PAK.

## GPS Navigation

*Global Positioning Satellites* have been called the next major utility. A roving flock of satellites on frequencies of 1227.60 and 1575.20 Megahertz whose spread spectrum differential phase measurements can tell you exactly where you are and how fast you are now moving. Typically to a navigation accuracy of a hundred feet or so. Which is better than the best topo maps. With care when using *differential* techniques, you can achieve land survey precision.

Your receivers can be wallet sized, including a built-in antenna. Even backpacker's versions are already available. Costs are presently in free fall, with \$600 receivers being a typical low end at this writing. Within three years, it is reasonable to expect a \$35 chip set and full receivers for under \$99. Within five, a \$45 *Radio Shack* Navicube.

Uses? What *can't* you do with low cost and universal navigation, position, and speed info? Vehicle location. Trucker's dispatch control. Robotics. Land surveying. Not getting lost on a hiking trail. All of the obvious military stuff. Toys. Orienteering. Remotely controlled vehicles. Pipeline maintenance. Well logging. Aircraft nav. Vacation car travel. Altimetry. Drug smuggling. Aerial platforms. Self-positioning maps on CD ROM. Offshore operations. Timber silvaculture. Sailboat competition. Archaeological excavations. Cross country skiing. Ore body mapping.

Or anyplace or anytime else you are outdoors and want to see a red dot that says "You are now here, are at this elevation, are going this fast, are headed in this direction, are accelerating at this rate, and the time is now."

A useful intro book on GPS is available from *Trimble Navigation*. The key government document ICD-GPS-200 is provided by *Space Systems Division MZEE*. A primitive and outdated but very informative GPS hacker construction project is offered by *DKD Instruments*. The leading trade journal is *GPS World*. And your best tutorials and most useful ongoing insider info and conferences are provided by the *Institute of Navigation*. Or see my *GENIE* PSRT files #363 HACK48.TXT and #396 HACK51.TXT.

## Spread Spectrum Communications

The GPS satellites are one of many emerging uses for *spread spectrum communications*. Spread spectrum comm sounds almost magic. Self addressing signals that are easily and reliably extracted from unbelievably deep noise and severe interference. Comm that can be highly secure and extremely difficult for most outsiders to detect. Many stations can be on the same center frequency at the same

time without interfering with each other. The licensing requirements are also much less of a hassle than traditional comm, since the field strength at any one frequency can be ridiculously lower.

Most spread spectrum comm is digital and frequency modulated. Each one or zero in your original message gets replaced by a carefully chosen and longer pseudo-random *spreading code*. Chosen such that your final transmitted bandwidth is very much broader than that needed by the original signal. On reception, the spreading codes will very strongly correlate, while much of the noise cancels.

It is sort of like having each and every AM radio station channel broadcasting the same song. By tuning to all of them at once, you can get your song to reinforce, and have most of your background noise cancel out or, at the least, severely reduce itself. Each channel can now operate at far less power. Especially if you already know the tune.

Uses? Military security and bugging devices obviously. And, of course, planetary probe comm. But all the newly emerging and more convivial applications lie in wireless data networks, both local area and city wide. For cellular phones. New pager services. Ham radio. Emergency fire, police, and ambulance comm. GPS satellites, where as many as 24 birds are simultaneously broadcasting on the same center frequency. In deep noise without interference.

At one time, spread spectrum comm looked obvious for voice and appliance data carriers routed over home power lines. But so many spike and noise filters are now in use that hopes are rapidly dimming for this particular ap. The radio frequency impedance of home and industry power lines have dropped dramatically in the last decade. Many power lines now offer an essentially dead short at low radio frequencies. So this particular hound may not hunt. But the rest of the pack is clearly off and running.

Something possibly off-the-wall. Possibly not. Spread spectrum is ideal for transmitting long distances through extreme noise. Would it not be a totally obvious choice for extragalactic communications? With multi-level codes, the dummies out there could determine that something was up, while the bright ones could receive the full set of plans in the same message. A multi-level marketing scheme which clearly beats sending out prime numbers forever.

I haven't yet gotten around to any really heavy duty research into spread spectrum, but here's a few resources to get you started: Just about all scientific publishers offer at least one book on spread spectrum theory. Dixon's *Spread Spectrum Systems* from *Wiley* being typical. The *ARRL* publishes a *Spread Spectrum Sourcebook*, mostly for ham radio applications. One key patent is #4,455,651. A new labor of love newsletter called the *Spread Spectrum Scene* promises to deliver lots more on this topic.

The May 92 issue of *Microwaves & RF* offers a current applications update. The *RADIO* board on *GENIE* gets into this, as does the *EE Times* trade journal. And, as usual, *Dialog* and *UMI* can quickly get you up to date. *Dialog* now has a one-quarter cost late evening service.

## Calling Party Identification

Many telephone operating companies are starting to offer a new group of *CLASS* services. By far the most popular one of these is *calling party identification*, or *caller id* for short. Caller id is just plain wonderful. Among its many

overwhelming benefits, when you come back from lunch, you have a free and no-hassle list of every one who tried to call you, with an asterisk beside anyone antsy enough to have called you twice.

A very vocal, totally irrational, badly misinformed, and negligibly small minority has now thrown out some legal challenges that have caused a general slowing of the rate at which caller id is becoming universally available. But the service already covers around a third of the country. Full coverage should take place within two years.

Production caller id receiver modules should soon be available from Hong Kong for under \$9. So the straight hardware opportunities are limited. But the software and applications possibilities are wide open. Especially when interactively combined with CD ROM or data bases.

Your actual caller id pulses are related to modem tones and are provided between the first and second telephone ring. Note that an ordinary unmodified modem can *not* be used to extract these tones. Because of the formatting.

In general, telephone information is available through their free *Bellcore 1992 Catalog of Technical Information*. The key document you need is TR-TSY-0030, while papers TR-TSY-00391 and FSD-02-1051 yield useful (but costly) additional background info.

The two largest caller id chip houses are *Motorola* and *Sierra*. Dr. Moto has a MC14557 chip and a MC145460EVK evaluation kit. Sierra offers their new SC11212 chip and several useful ap notes. Although Motorola is making the most noise, I overwhelmingly prefer Sierra's SC11212. Two companies offering the preapproved Type 68 interface circuits required for caller id are *Dallas Semiconductor* and *Cermetek*. *Hello Direct* offers several ready-to-use caller id standalone products.

I've already run quite a bit of background tutorial info on caller id. See my *GENIE* PSRT files #275 HACK43.TXT, #374 HACK49.TXT and #391 HACK50.TXT or, for hard copy, my *Hardware Hacker III* reprints.

### Switched Reluctance Motors

Most of the innovation in electromechanical power has long since been coming down outside of the United States. For instance, for over five years now, Japan has routinely offered air conditioners that are twice as efficient as ours, with SEER ratings of 16 and higher. Besides offering far more comfort.

The efficiency secrets do include a variable speed scroll compressor, a variable speed air handler, and multiple zone control through fuzzy logic. Your local HVAC contractor refuses to sell these to you because of "code" problems, telling you that there is "no demand."

"Sides, it ain't in mah *Grainger* catalog."

By the way, the *HVAC News* trade journal is one fairly useful source for info on most current US antiquated air conditioning technology.

OK. We've got these beasts known as *ac induction motors*. Which were a stupendously great idea when Telsa first thunk them up. And still remain the most popular type of appliance motors in use anywhere in the world. But most ac induction motors suffer from what is turning out to be a fatal flaw. They only run over an undesirably high and very narrow speed range. For instance, a typical quarter horse motor might run properly only over a speed range of 1725

### EMERGING TECHNOLOGY RESOURCES

**Advance R&D**  
359R Main Street  
Athol, MA 01331  
(508) 249-4696

**ARRL**  
225 Main Street  
Newington, CT 06111  
(203) 666-1541

**Aware Inc**  
One Memorial Drive  
Cambridge, MA 02142  
(617) 577-1700

**Cermetek**  
1308 Borregas Avenue  
Sunnyvale, CA 94088  
(408) 752-5000

**Dallas Semiconductor**  
4350 S Beltwood Parkway  
Dallas, TX 75244  
(214) 450-0400

**Dialog**  
3460 Hillview Avenue  
Palo Alto, CA 94304  
(415) 858-2700

**DKD Instruments**  
1406 Parkhurst  
Sima Valley, CA 93065  
(805) 581-5771

**Dr Dobb's**  
411 Borel Avenue #100  
San Mateo, CA 94402  
(415) 358-9500

**EE Times**  
600 Community Drive  
Manhasset, NY 11030  
(516) 365-4600

**EPRI Journal**  
5310 Derry  
Agoura, CA 91301  
(800) 638-2581

**Galco**  
26010 Pinehurst Drive  
Madison Heights, MI 48071  
(800) 521-1615

**GENIE**  
401 N. Washington St.  
Rockville, MD 20850  
(800) 638-9636

**GPS World**  
PO Box 10460  
Eugene, OR 97440  
(503) 343-1200

**Grainger**  
2738 Fulton Street  
Chicago, IL 60612  
(312) 638-0536

**Hello Direct**  
140 Great Oaks Blvd  
San Jose, CA 95119  
(800) HI-HELLO

**Home Power**  
PO Box 130  
Hornbrook, CA 96044  
(916) 475-3179

**IEEE SP**  
445 Hoes Lane  
Piscataway, NJ 08855  
(908) 981-0060

**Institute of Navigation**  
1026 16th Street NW #104  
Washington, DC 10036  
(202) 783-4121

**Jones & Bartlett**  
20 Park Plaza  
Boston, MA 02116  
(617) 482-3900

**Lindsay Publications**  
PO Box 538  
Bradley, IL 60915  
(815) 935-5353

**Microwaves & RF**  
611 Route 46 West  
Hasbrouck Hgts, NJ 07604  
(201) 393-6286

**Motion Control**  
800 Roosevelt Road E-408  
Glen Ellyn, IL 60137  
(708) 469-3373

**Motorola**  
5005 E McDowell Road  
Phoenix, AZ 85008  
(800) 521-6274

**MotorTechniques**  
120 S Chaparral Ct #200  
Anaheim, CA 92808  
(714) 283-1123

**Nature**  
65 Bleecker Street  
New York, NY 10012  
(212) 477-9628

**PCIM**  
2472 Eastman Avenue #33-34  
Ventura, CA 93003  
(805) 658-0933

**Planetary Asso. Clean Energy**  
191 Promenade du portage  
Hull PQ CANADA J8X 2K6  
(819) 777-9696

**Science**  
1333 H Street NW  
Washington, DC 20005  
(202) 326-6400

**Sierra Semiconductor**  
2075 N Capitol Avenue  
San Jose, CA 95132  
(408) 263-9300

**Space Systems Div MZEE**  
LA Air Force Base, POB 92960  
Los Angeles, CA 90009  
(310) 363-0125

**Spread Spectrum Scene**  
PO Box 2199  
El Granada, CA 94018  
(510) 278-3157

**Springer-Verlag**  
175 Fifth Avenue  
New York, NY 10010  
(212) 460-1500

**Surplus Traders**  
PO Box 276  
Alburt, VT 05440  
(514) 739-9328

**Synergetics**  
Box 809  
Thatcher, AZ 85552  
(602) 428-4073

**Trimble Navigation**  
585 North Mary Avenue  
Sunnyvale, CA 94086  
(800) TRI-MBLE

**UMI**  
300 North Zeeb Road  
Ann Arbor, MI 48106  
(800) 521-3044

to 1800 revolutions per minute.

These days, a high energy efficiency is becoming super important. For energy efficiency, you'll want to vary your input speed to get precisely the level of tail twisting you need. The centermost key to appliance energy efficiency is often a widely ranging and an exactly controllable variable speed motor. One that runs at useful slower speeds without mechanical reduction.

While pulse modulation and vector controllers are slowly being offered for ac induction motors, these systems remain costly and quite complex. These controllers have to change both the frequency and the supply voltage. And they still work only over a rather limited speed range. Many of them are also extremely noisy, producing strong harmonics in the mid audio range. Tweeeeee. They also can cause turf fights with the motor's starting mechanism.

The bottom line is that it is long past time to flush the ac induction motor since it is inherently a single speed device. The heir apparent replacement is the *switched reluctance motor*. While widely used in Europe, they are only being newly rediscovered here in the US.

A switched reluctance motor uses groups of simple half pitch windings on the stator. The rotor is a rotating magnet in smaller sizes, or soft iron salient poles in larger ones. A companion speed and position sensor is needed, and can be done with optics or Hall Effect sensors.

An external microcontroller is required. As any pair of coils are excited, the rotor will try to align itself, either by magnetic attraction or by trying to minimize the reluctance of a magnetic path. By properly sequencing the windings, continuous rotation at any speed in either direction for any reasonable loading is easily achieved. Speed and torque regulation are inherent in the design.

When compared to an induction motor, you gain higher efficiency, reversibility, self-starting, double peak power, and an incredibly wider speed range.

For a good background tutorial, try *High Performance Switched Reluctance Drives* in the February 1992 issue of *Motion Control* on pages 50-55. Besides this trade journal, additional developments are likely to appear in the *PCIM*, *Motion*, and *MotorTechniques* trade journals, along with the IEEE transactions on *Energy Conversion* and *Industrial Applications*. Plus *Dialog* and *UMI*.

Now for the neat part: *Any car alternator is very easily converted into a switched reluctance motor!* And these are available in junkyards for as little as \$5, especially if you don't care which make or model, can use one with a blown diode or two, can remove it by yourself, and don't need the regulator to go with it.

At high speeds you can use the alternator as a motor; at lower ones as a three phase stepping motor. I've seen some videos of some outstanding homebrew three axis wooden sign routers built up out of junk alternators.

Naturally, the results probably will not be as good as properly designing a switched reluctance motor up from scratch. But the economics certainly make looking further into this worthwhile.

To start, the internal wye connection is brought out as a common terminal giving you three phases of windings. The windings are best rewound spanning single slots, with high ampere turns being the name of the game here. But don't saturate the iron. The rotor and slip rings are simply run as

a rotating electromagnet. For motor use, external speed and positioning sensing has to be added. When used as a low speed stepper, no special sensing is required.

An ABC sequence runs you in one direction; ACB in the other. You are thus fully reversible.

Power MOS transistors make good drivers, with *Galco* being one useful source. For your initial experiments, a Commodore-64 or some other older microcomputer should work out just fine as an economical controller. Eventually, you would substitute an embedded microprocessor.

For more of the fundamentals on modifying alternators, see my #483 NUTS7.PS and #284 HACK44.TXT files up on *GENIE PSRT*. A good book source on traditional alternator rewinding is *Lindsay Publications*.

## Aerogels

What if they gave a new form of matter and nobody came? The stuff is called an *aerogel*. These are solids that look like solidified smoke. Solids that have the density of air or even less. In fact, all that prevents certain of the aerogels from floating away are all of those air molecules stuck inside. Aerogels can transmit light, but block heat, electricity, and sound.

Inorganic aerogels can be made from plain old sand. I'd guess that copper mine tailings dumps would be an ideal raw material source. Organic aerogels can be made from seaweed and are actually edible. The process starts out as an ordinary liquid gel followed by sort of a medium tech freeze drying. The final aerogel consists of solid and gas, rather than the solid and liquid you found in your last bowl of lime Jell-O.

The obvious potential uses include high performance insulation, new packing materials, and energy absorbing structures. Plus new composite materials with unheard of strength to weight ratios. The nonobvious apps could range from diet foods to novel weaponry. If some third world empire gets out of line, you simply foam the whole country in place. Camels and all.

It is not clear how to make any bucks on this just yet. Especially on a small scale and low budget. But the stuff is so new and so exciting that it somehow doesn't seem to matter all that much.

Two good aerogel papers appeared in the February 16, 1990 and February 21, 1992 issues of *Science*. Bounce these backwards through the *Science Citations Index*. There's also an *Aerogels* book offered by *Springer-Verlag*.

For this month's contest, just tell me about any emerging *Midnight Engineering* opportunity. There will be all of the usual *tinaja quest* and *Incredible Secret Money Machine* book prizes. Let's hear from you. ♦

---

*Microcomputer pioneer and guru Don Lancaster is the author of 27 books and countless articles. Don maintains a no-charge technical helpline you'll find at (602) 428-4073, besides offering all his own books, reprints, and various services. Don has a free brochure chock full of his new insider desktop publishing secrets waiting for you. The best calling times are 8-5 weekdays, Mountain Standard Time.*

*Don is also the sysop of GENIE PSRT (800) 638-9636 where a special area has been set aside for you Midnight Engineering readers. Or you can reach Don through his Synergetics, at Box 809, Thatcher, AZ 85552.*



# Emerging Opportunities III

It sure is rewarding for me to see you other Midnight Engineers picking up on and successfully going with some of our previous emerging opportunities. All in your own small scale home-based Money Machines.

Several examples here include John Rees who offers a great video on converting car alternators into power stepper motors. And Martin Carbone whose new desktop finishing products include a pair of very low cost scoring machines for boxmaking and bookbinding.

Or Frank Miller who has bunches of useful direct toner printed circuit products. Or Kevin Bennet with his easy to do "raised print" laser thermography. That uses nothing but a small desk lamp. Or Stan Griffiths and his fine new book on recycling *Tektronix* classic oscilloscopes.

Or Kirk McLoren who has a new *Micro Cogeneration* book that shows you how homemade power can actually end up cheaper than utility power.

Let's return to the scene of the crime. Here's what I see as the current crop of emerging opportunities. Along with several *GENie* PSRT filenames you could go to for more details. Stuff that suddenly has become cheap enough and real enough, yet remains fuzzy enough and undeveloped enough for superb *Midnight Engineering* potential...

## Short Haul Telemetry

Micropower radio and infrared transmitters have gotten super small and very cheap. To the point where they can be used for all sorts of data comm over ranges of, say, four to six feet. There are a lot of new possibilities here. I like to call the sum total of these devices *short haul telemetry*.

For instance, there are all kinds of new uses for ordinary TV remote controls. There are antishiplifting tags. And implanted animal monitors. And schemes to get data on or off a rotating shaft. Inventory controls. Security systems. Intelligent data tags. New wireless mice and modems. Car locks. 3-D position sensors. Attitude detectors.

A brand new trade journal that addresses these devices is *Wireless Design and Development*.

One low cost and grossly underutilized short haul system is called an EKG heart monitor. This is normally used to optimize aerobic exercise sessions. You have a strap that wraps around your chest. The strap picks up your electrical heartbeats and converts them to transmitted 36 cycle bursts of 5 kHz rf energy. These low frequency waves are then picked up using a nearby wristwatch or bicycle mounted computer display. The big advantage is that they perform reliably during strenuous exercise. Cheap finger or ear-clip infrared units do not. Look Ma, no wires.

All you really have here is an air core transformer. With the core being the distance between your chest and your wrist or handlebars. Plain old near field inductive coupling is all you require for effective comm.

But wait. What do we really have here? We have a tiny, lightweight, sealed and waterproof transmitter. With a one year or longer life from its internal lithium cell. That can handle a data rate of zero to 200 Hertz or so. At a retail list price of \$22, far less in quantity. Providing a signal that is handily received by a coil and an op-amp or two. Largely unidirectional, except for deep axis nulls.

Two leading brands of these devices are *Polar* and *Vetta*. More details on their internal workings in HACK68.PS. By the way, a dental X-ray is a dandy way to reverse engineer sealed modules of this type.

One big new use I see for short haul telemetry...

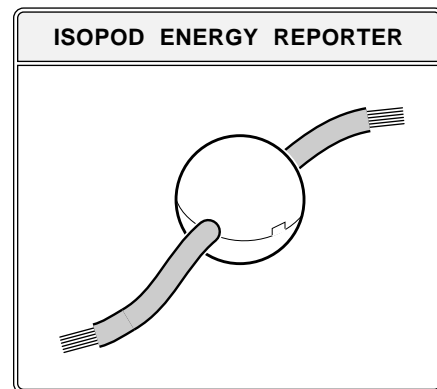

The key to home energy awareness and conservation lies in easily measuring how much power you are using at any time. From there, you can intelligently optimize what power you use when. The big problem here has been that current sensors are very expensive, highly inconvenient and usually have to be electrician installed.

Note that most current sensors require that one (but not both) of the supply wires run through them.

Instead, the isopod simply snaps on your power lines as they enter your house. Inside the tennis-ball shaped device is a current transformer that both provides micro supply power and a data rate proportional to current. The data gets safely transmitted to a nearby receiver.

Each isopod can either output an identifying code or else speak only when spoken to. Your transmitted data can be synchronized to the current zero crossings. The receiving unit can sort out which signals come from which sensors. The receiver can also measure the phase angle to separate

real from reactive power. Actual power consumed can be found by multiplying the real component of the measured current against the supply voltage.

More on the isopod concept appears in HACK47.PS.

## Non-linear Editing

I get lots of helpline calls for some way to "synchronize" two video signals. The synchronizer is easy enough, but the next thing you'll be asking for is a frame grabber. And a time base corrector. You will then demand switchers and chroma keyers. And a costly single frame write VCR. And SMPTE time code striping. And by that time, the *Video Toaster* from *Newtek* starts looking very attractive.

All of which ends you up with a room full of expensive gear. And you will *still* be stuck with awful final results because of the horrendous "generation loss" of most of the low-end video recording systems.

Instead, if you simply store each video field as digital data, you could completely eliminate *all of the above*. For digital video fields are inherently self-synchronizing, self-correcting, self-timing, self-switching and self keying.

With zero generation loss and no need for expensive gear for single frame recording. Even more important, digital video can be random accessed and combined in any order at any time. Using a plain old personal computer.

Which is what *non-linear editing* is all about. The ability to create a perfect generation-loss-free digital video master by gathering up what you want from where you stashed it. Layer after layer. Matte after matte. And do so ridiculously faster, cheaper, and infinitely more flexibly than any of the traditional and primitive *A-B roll editing* techniques.

The only little kicker is that you do need some random access storage to hold the video data. Quite a bit, in fact. Typical "broadcast quality" or 4-2-2 video takes around one byte per color pixel, so a single field is something around a quarter meg. Say fifteen megs per second and just under a gig per minute. Thus a half hour segment seems to need around thirty gigabytes of storage.

A year or two ago, such massive storage systems would have seemed absurd. But there's several new developments that make them routinely available. First and foremost, you can run out and cheaply buy a three Gigabyte hard disk. It doesn't take much in the way of smarts to use ten of these to make a thirty gig virtual drive.

Secondly, we now have data compression systems. Just using plain old LZW lossless data compression should buy you three to one or so in storage. The next step up is called DCT or JPEG compression. Which can often give you 30:1 squashing and still have acceptable quality for most users. The simplest and cheapest way to explore DCT is with the filters built into PostScript level II.

Both JPEG and its underlying DCT compression work on single images. For dramatic compression, you can go to MPEG techniques that are based on saving only motion-estimated changes between groups of successive fields. Real time MPEG systems are only starting to become available at acceptable prices.

Third, the MPEG and JPEG compression "standards" are exactly the same as a 1903 standard on aviation. These are already absurdly obsolete. Better solutions use wavelet technology from *Aware* or fractal techniques from *Iterated Systems*. More in HACK60.PS and HACK69.PS.

## EMERGING RESOURCES

**Aware, Inc.**  
One Memorial Drive  
Cambridge, MA 02142  
(617) 577-1700

**Bennet LaserBrite**  
720 Fourth Street, SW  
Rochester, MN 55902  
(507) 280-9101

**C & H Sales**  
PO Box 5356  
Pasadena, CA 91117  
(800) 325-9465

**Martin Carbone**  
2519 Bath Street  
Santa Barbara, CA 93105  
(805) 682-0465

**Dialog Info Services**  
3460 Hillview Avenue  
Palo Alto, CA 94304  
(415) 858-2700

**GENIE PSRT**  
401 N. Washington St.  
Rockville, MD 20850  
(800) 638-9636

**Stan Griffiths**  
18955 SW Blanton  
Aloha, OR 97007  
(503) 649-0837

**Iterated Systems**  
5550A Peachtree Pky #650  
Norcross, GA 30092  
(404) 840-0310

**Kirk McLoren**  
3309 1/2 Lynn Avenue  
Billings, MT 59102  
(406) 652-0018

**Frank Miller**  
3535 Stillmeadow Lane  
Lancaster, CA 93536  
(805) 943-4746

**OralSafe**  
43529 Ridge Park Drive  
Temecula, CA 92590  
(800) 237-8825

**Parallax**  
3803 Atherton Rd. #102  
Rocklin, CA 95621  
(916) 624-8333

**Polar**  
99 Seaview Blvd.  
Port Washington, NY 11050  
(516) 484-2400

**John Rees**  
Rt 1, Box 1551  
Sautee, GA 30571  
(706) 865-5495

**Vetta/Orlander USA**  
14553 Delano St #210  
Van Nuys, CA 91411  
(818) 780-8808

**Wireless Design & Devel.**  
301 Gibraltar Drive  
Morris Plains, NJ 07950  
(201) 292-5100

## The Digital Bogey

With one or two more memory iterations, we will soon have terabyte storage routinely and cheaply available. So, computers of human brain capability are virtually certain to show up in the next few years. Which can lead us to the *Digital Bogey*. The next step beyond nonlinear editing.

Given enough memory, there is no reason at all why *everything* in a movie cannot be an alterable data base. A cyberthespian's persona could get programmed at both the micro and macro levels. There would be no difference at all between actors, extras, props, vehicles, animation, and special effects. Each would simply be alterable numbers in a humongously large data base.

All of which means that an individual working at home will soon be able to produce an entertainment experience comparable to a first-run movie at a total cost of \$45 or so. Which will be a *one million to one* reduction of the costs of producing entertainment. Distribution, of course, would be via *Internet IV*. And on library teracubes, each of which will hold a decade's worth of movies.

All of which should profoundly affect the smog levels in the LA basin. *All* types of LA smog. No more grips or gaffers or foleys. Or any third assistant makeup supervisor safety director best boys.

Even more profound, we should be able to throw all of the original Bogey movies at the computer and then have it run off dozens of new ones. I can hardly wait.

There's bound to be a buck in here somewhere. More on the Digital Bogey in HACK71.PS.

## FM RBDS Services

Commercial FM stations have a new *Radio Broadcast Data Service*. Described in an EIA/NAB standard. Intended

uses are to identify their station, the singer and the song, traffic and weather, and emergency warnings.

But there are all sorts of emerging new uses involving differential GPS navigation correction info, custom paging, and tightly targeted coupon radio services.

The subcarrier is at 57 kHz and the baud rate is 1200 in any of several carefully specified formats. The SAA6579 from *Philips* is one low cost decoder chip.

More on RBDS is found in HACK73.PS.

### Cheap Air Turbines

Dentists have rightly concerned themselves with AIDS and related viruses. As a result, many of them are going to single use throwaway tools. There is one new *disposable handpiece* from the *Oralsafe* folks that retails for \$14. This gem can be easily cut down into a miniature air turbine the size and mass of a plotter pen.

Actually, their turbine is nothing but a nylon pawl and two medium quality ball bearings. About fifty cents worth. Air turbines are usually high speed devices, well suited to drilling tiny printed circuit board holes.

The usual setup is to have a compressor, accumulator, and regulator in the 60 PSI "shop air" range. The needed parts are cheaply available surplus from *C & H Sales*. A restrictor valve is placed in series with the turbine to adjust your no-load pressure at the turbine to around half this. If you don't want to get into a real pneumatic system, a plain old truck tire should also work out just fine.

On a CAD/CAM anything, the heavier the device you shove around, the worse the design problems. Sort of like pounds of extra satellite weight needing extra tons of fuel at the pad. So, the lighter and smaller the working head of your CAD/CAM system, the simpler the design.

Air turbines run extremely fast. For heavier work, some sort of a compact gear reduction head can give you slower speeds and more tail twisting.

One area where CAD/CAM offers exceptional untapped opportunities is jewelry making. A machine having a three inch range along each axis will do just fine. And is easily handled by low cost stepping motors. The usual route is to cut a machinable wax and then convert it into metal or whatever by a lost wax process. See HACK76.PS.

### Sonoluminescence

Take a small tank of water and couple some fairly loud ultrasonic energy into it. Under certain circumstances, any tiny entrapped air bubbles may emit a clear blue light!

This effect is called *sonoluminescence*. At present, this is only a well researched laboratory curiosity, but it has some exciting potential. It appears the blue light comes from a heating of the entrapped air to temperatures of 10,000 and possibly as high as 50,000 degrees. What is happening is that the bubble spherically concentrates energy at its center by *twelve* orders of magnitude. Yup, a million million.

The "blue" light is actually ultraviolet centered at 310 nanometers. Even more amazing, the light occurs in brief pulses a mere 50 *picoseconds* long.

What good is this stuff? Well, because of fundamental physical laws, a blue anything can be very tricky to do. Sonoluminescence should also be a low cost source for the brief light pulses needed in laser spectroscopy.

The astonishingly high energy concentration might be

adapted to solar energy collection. Possibly even scaled up to build a small plasma torch that might be used to safely vaporize hazardous materials.

There are hundreds of current sonoluminescence papers. The simplest and quickest way to pick them up is with the *Dialog Information Service*, which is newly available on a moderate cost cash-and-carry basis on *GENie*. I have also posted a few key papers to HACK73.PS.

### Royalty-free Real PostScript

The general purpose PostScript computer language is rather adept at producing fine typography and smooth graceful curves. But real PostScript has not been available for typical Midnight Engineering projects like homebrew embroidery machines, glass etchers, sign routers, Santa Claus machines, CAD/CAM mills, pc drills, vinyl cutters, engravers, and such. At least not without having to pay outrageously high royalties. But no more.

There are now three effective routes which instantly let you apply PostScript to your homebrew projects.

The first is to use any old PostScript level II printer to do the tricky PostScript stuff for you. Teach the printer to use a *crossporting* technique where it writes motion codes to an unused serial or SCSI port. A simple brain-dead micro on your mechanical whatever then converts the motion codes to machine actions. The *Basic Stamp* from *Parallax* is ideal for this sort of thing and costs only \$39.

The second route is to borrow the printer only when you want to start a new job or pattern. The output motion codes are then saved to host disk and output when and as needed from your host. By using a plain old comm program to pull what you need from a resident library.

Third, there is some shareware called *GhostScript* that gives a fair to middlin' imitation of PostScript that runs on just about any host computer. GhostScript gets normally provided as a C-language source code, and in compiled versions for most popular host computers. Yes, GhostScript does provide screen previews. Two sources of GhostScript are GHOST252.MAC and GHOSTEXE.ZOO.

The trick here is to apply PostScript's *flattenpath* and *pathforall* operators to convert output into simple stroke vectors that you can recode and send to your homebrew machine. It is trivially easy to make all these commands HPGL or Gerber compatible.

Full details in POSTVECT.PS and NUTS19.PS. But one important tip: Earlier versions of PostScript used locked font character paths that were tricky to access. Be sure to use PS level II with its fully open font paths. ♦

---

*Microcomputer pioneer and guru Don Lancaster is the author of 32 books and countless articles. Don maintains a no-charge technical helpline you'll find at (520) 428-4073, besides offering all his own books, reprints, and various services. Don has a free new catalog crammed full of his latest insider secrets waiting for you. The best calling times are 8-5 weekdays, Mountain Standard Time.*

*Don is also the sysop of GENie PSRT where a special area has been set aside for all you Midnight Engineering readers. For modem access, dial (800) 638-8369. Then enter HHH followed by JOINGENIE,DMD524 Or you can reach Don at Synergetics, Box 809, Thatcher, AZ 85552.*

*Internet access: SYNERGETICS@GENIE.GEIS.COM*

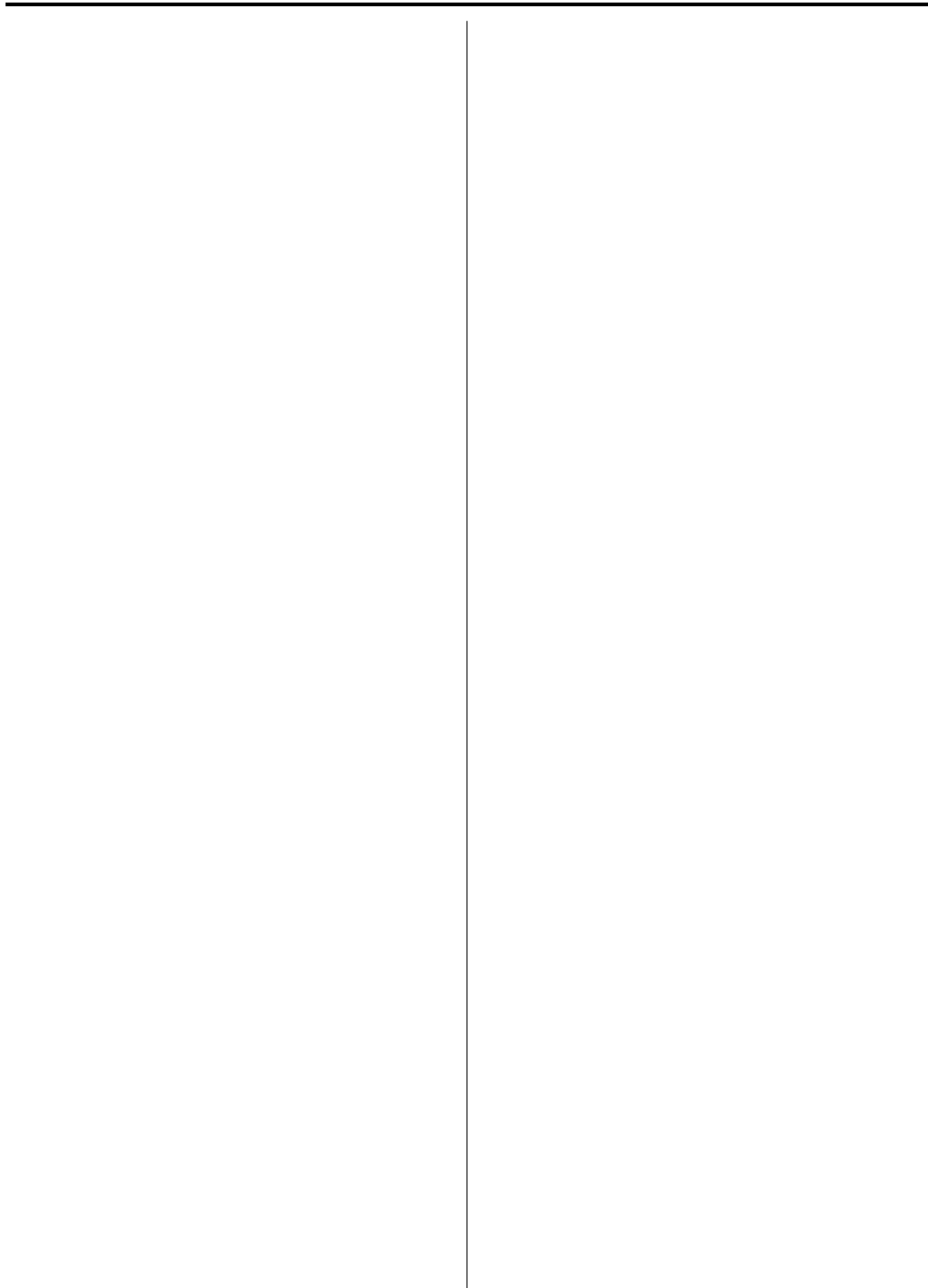

# Emerging Technical Opportunities IV

I guess it's once again time to look into some emerging new technologies. Stuff having really high *Midnight Engineering* potential. Concepts newly turning some awareness corner through rapidly shifting paradigms. Stuff that remains largely free of Fortune 500 involvement.

There are bunches of ways you might tune yourself into exploitable new developments. The foremost two are the News and Comment section of *Science* magazine and the Technology section (usually on page B4) of the *Wall Street Journal*. Also useful and handy are all the usual suspects—*Scientific American*, *Science News*, and good old *Popular Science*. Plus my favorite – *The Whole Earth Review*.

I have personally found the industry trade journals and those labor-of-love newsletters to be a treasure trove for new ideas and concepts. As I've mentioned a time or two before, *Ulrich's Periodicals Dictionary* holds the keys to the kingdom. Listing tens of thousands of trade journals and magazines. Many free to "qualified" subscribers. Find this on the reference shelf at your favorite library or online through *GENie* or another commercial service.

For the labor-of-love pubs, there's a unique *FactSheet Five* mag. Listing thousands of underground 'Zines.

For instant access to everything about anything, use the *Dialog Information Service*. Or any of countless thousands of web sites. Use my [www.tinaja.com](http://www.tinaja.com) for access.

Finally, I like to think that my *Tech Musings*, *Guru's Lair*, and *Resource Bin* columns can be of help in steering you to new ideas. As usual, these columns and the files mentioned below are available on my [www.tinaja.com](http://www.tinaja.com). For starters, you can pick up earlier emerging technologies as [EMERGOP1.PDF](#) [EMERGOP2.PDF](#), or [EMERGOP3.PDF](#). For paradigm chasing, you can try [PARADIGM.PDF](#).

Here's my current crop of new candidates...

## Push Me Pull You

It is very rare that any fundamentally new mechanism emerges. Picture a machine tool that looks sorta like the bottom half of a flight simulator. A heavy base. Above it "floats" a small working head. The two are connected by six crossed *jackscrews* or linear actuators.

By computer coordinating the extension or compression of each leg, any reasonable head attitude, position, and motion can be swiftly created.

Now for the unique part: *There are no precision ways!* Nothing slides on anything else. No bending moments. All forces directly push or pull. All motions are on plain old ball bearings. The machine head can go nearly anywhere

and do anything. And only has to be rigid enough to allow for tool loading reactions.

Carving such things as turbine blades are now trivial.

Compared to conventional lathes and milling machines, these new devices are potentially much cheaper, stiffer, far more accurate, and significantly faster. One name for them is a *Hexapod*; another is a *Virtual Axis Machine*.

Those real time coordinate transformations required to change actuator positions into head attitude can be fairly ugly. Especially at high speed. The method only works by using the latest of microcontroller techniques.

The extensions to low end robotics and virtual reality applications are obvious.

Start with *A Floating Revolution for Automation*. Found on pages 58-63 of the August 15, 1994 *Design News*. Then check out *Nice Legs* on page 36 of *Scientific American* for December of 1995. Or see [HACK82.PDF](#).

Some fundamentals of vector-to-step conversion appear in [HACK83.PDF](#)

## The Mystery Band

How far is it from radio to heat? A lot further than most people suspect. Conventional microwaves top out around 300 Gigahertz. A warm human bod radiation peak checks in just over 30 Terahertz. The region from 300 Gigs to 10 Terahertz is what I call the *Mystery Band*. Others call it *submillimeter wavelengths* or *quasi-optical frequencies*.

So far, *this spectrum is almost totally unused!* The radio astronomers do have a pair of narrow atmospheric windows they research near 600 Gigs, but that's about it. There is enough bandwidth here for 1,600,000 HDTV signals, plus a dozen personal paging fax modems for nearly everybody that wants one. Using tiny high gain antennas.

Kiddies, we are talking a 30:1 frequency range here. *Almost five octaves!* Buckets upon buckets of sheer raw bandwidth. Just sitting there. Totally up for grabs.

Best of all, the *entire* mystery band remains largely license free! There is very little in the way of FCC regs. You are free to start up your own tv station at any power level you want. Any place. Any time.

The only two tiny little gotchas are that mystery band signals don't travel all that well over longer atmospheric distances. Especially in the rain. Worse, decent oscillators and amplifiers for the mystery band did not exist until very recently. So far, the radio astronomers use a "Get out of Dodge" technique where they'll immediately downconvert into manageable high microwave frequencies.

Mystery band amplifiers, especially low noise ones, do remain a big problem.

There's two brand new mystery band power generation schemes. In one, you build up an array of black antennas. Then, you whap the array with a laser. The incoming light photons get absorbed by the black, and their energy gets re-radiated in your desired mystery band frequency. See *Science* for June 25, 1995 for details.

The other is called the *accordion method*. In which you generate some microwaves in a plasma and then literally squash the plasma by blasting one end of it with a laser. The radiation upconverts by being squashed together. Sort of the exact opposite of the *Doppler Effect*. Details again in *Science*. This time in the March 24, 1995 issue.

Newly emerging mystery band apps include imaging of integrated circuits and biologicals. Two papers to get you started: *Terahertz pulses create diffraction-limited images*. In *Laser Focus World* for July 95, pages 15-19. And *THz waves see through objects* in *E.E. Times* for June 12, 1995.

Your best traditional source for mystery band info is the obscure and pricey *International Journal of Infrared and Millimeter Waves*. The *Radio Observer* from the *Society of Amateur Radio Astronomers* is also handy.

Mystery band fundamentals appear in [HACK84.PDF](#), with further details in [MUSE92.PDF](#). For high frequency resources in general, try [RESBN26.PDF](#).

## PIC Microcontrollers

The word should be out by now. The PIC is *the* micro of the decade. It completely blows the competition away on all counts. Utterly and totally. Owing partially to its 3X speed and 3X code length advantages. But mostly to its elegant simplicity, its off-the-shelf allocation-free availability, and its incredibly clean architecture.

To the point where today it is absolutely inexcusable to ever again use, say, a 555 timer. Or any other bits and pieces TTL/CMOS hardware lashup.

Most PIC instructions are *one* byte long and execute in *one* clock cycle! Once you get with the program, it is a simple matter to do a multiply-by-twelve in four bytes and four cycles. Or build a sinewave with six and six.

No matter what your *Midnight Engineering* venture, you will do a faster, better, and cheaper job if there are one or more PIC chips involved with it.

Let's see. Start with the bingo card and the *Microchip Technology, Parallax, Transdata, Micro Engineering Labs*, and similar ads you're likely to find scattered around this issue of *Midnight Engineering*.

Then, get the *Microchip Data Book* and *Microcontroller Applications Manual* from *Microchip Technology*. Next, pick up the *BASIC Stamp* from *Parallax*, and the *PIC Tools* from *Scott Edwards Electronics*.

*Circuit Cellar* is now big on PIC aps. Projects also now appear in *Electronics Now* and *Nuts & Volts*.

Speaking of which, Scott Edwards also runs a great series of PIC columns in *Nuts & Volts*.

I've got some of these up on [www.tinaja.com](http://www.tinaja.com), along with a lot of additional [PIC tutorials](#) and links.

I've also got bunches of my own PIC stuff here. You can check [HACK87.PDF](#) for some PIC resource listings. Or see [MUSE88.PDF](#) for PIC fundamentals, and [MUSE94.PDF](#) for a *Basic Stamp II* introduction.

## Magic Sinewaves

*Magic Sinewaves* are very long sequences of repeating binary ones and zeros. When connected to an ordinary "H-bridge" power driver, they create premium high power sinusoidal waveforms of precisely controlled amplitude and amazingly low harmonic distortion.

Important uses of magic sinewaves include induction motor speed controls, electric automobiles, solar panel conversion, battery inverters, and home energy efficiency improvers. Compared to traditional PWM or *pulse width modulation*, magic sinewaves require far fewer switch flips to get the same or significantly better results. Thus, magic sinewave efficiency is much higher and distortion is far lower. Far less high frequency energy is involved.

Costs can also be significantly lower, owing to more economical output stages and to smaller heatsinks. Magic sinewaves are also low end micro friendly.

There are vastly more magic sinewaves than there are particles in the universe. Sadly, an exhaustive search or random grab won't hack it. The trick has been developing specialized, efficient, and effective tools to filter out the handful of useful ones. Today, magic sinewaves represent a billion dollar opportunity.

I've got a free reprint on magic sinewaves for you if you call or write me here at *Synergetics*. Formal proposals and tutorial packages on consulting, seminars, source code, working chips, and co-developer programs are also offered to serious inquirers.

The reprint is also available as [MSINPROP.PDF](#). There are hundreds of additional magic sinewave files provided in the [www.tinaja.com](http://www.tinaja.com) Magic Sinewave library shelf.

## Solitons

Much of communication gets done by sending a pulse into a media and hoping part of it comes out some distance away at the other end. Three effects conspire to limit how far you can send a pulse: *Reflection* off lumps in the media, *Dispersion* in which the waveshape degrades over distance, and *Dissipation* where any frictional losses in the media convert the pulse energy into low grade heat.

Dispersion is often caused by certain pulse frequencies traveling faster than others. The net result is a flattening of the pulse. Limiting its detectable height and widening its measurable resolution.

By carefully selecting a suitable *nonlinear* media and then exactly controlling a pulse waveshape, a special pulse known as a *soliton* can result. Short for *solitary wave*. The nonlinear media slows down the *highest amplitude* portions of the wave, *exactly compensating* for its dispersion. The pulse goes on and on without changing its shape. Only the dissipation and reflections ultimately do it in.

Soliton pulses can easily be sent around the world on an optic fiber. They also work well on canals and on tramway cables. The big deal is that you can send signals further and faster. Starting with lower power and using fewer repeaters spaced further apart along the way.

You'll find some 8300+ Soliton references on *Dialog*. Start with Russell Herman's *Solitary Waves* in the July 1992 issue of *American Scientist*.

I've got a soliton tutorial and key paper list up for you as [HACK77.PDF](#).



## EMERGING OPPORTUNITY RESOURCES

<b>American Scientist</b> Box 13975 Research Tri Pk NC 27709 (919) 549-0097	<b>Parallax</b> 3805 Atherton Rd #102 Rocklin CA 95765 (916) 624-8333
<b>Circuit Cellar Ink</b> 4 Park St #20 Vernon CT 06066 (203) 875-2751	<b>Photocraft Inc</b> PO Box 408 Geneva IL 60134 (815) 786-2885
<b>Design News</b> 8773 S Ridgline Blvd Highlands Ranch CO 80126 (303) 470-4000	<b>Popular Science</b> 2 Park Ave New York NY 10016 (212) 779-5000
<b>Dialog Information Services</b> 3460 Hillview Ave Palo Alto CA 94304 (415) 858-2700	<b>Radio Observer</b> 7605 Deland Ave Ft Pierce FL 34951 (407) 464-2118
<b>Scott Edwards Electronics</b> 964 Cactus Wren Lane Sierra Vista AZ 85635 (520) 459-4802	<b>Science/AAAS</b> 1333 H St NW Washington DC 20005 (202) 326-6400
<b>EE Times</b> 600 Community Dr Manhassat NY 11030 (516) 365-4600	<b>Science News</b> 1719 N Street NW Washington DC 20026 (202) 785-2255
<b>Factsheet Five</b> R Seth Friedman PO Box 170099 San Francisco CA 94117	<b>Scientific American</b> 415 Madison Ave New York NY 10017 (212) 754-0550
<b>GENie</b> 401 N Washington St Rockville MD 20850 (800) 638-9636	<b>Synergetics</b> Box 809 Thatcher AZ 85552 (520) 428-4073
<b>Int JI Infrared &amp; mm Waves</b> 233 Spring St New York NY 10013 (212) 620-8000	<b>Transdata</b> 14330 Midway Road #104 Dallas, TX 75224 (214) 980-2960
<b>Laser Focus World</b> One Technology Park Dr Westford MA 01886 (508) 692-0525	<b>Ulrichs Dictionary</b> 121 Chanlon Rd New Providence NJ 07974 (908) 771-7714
<b>Microchip Technology</b> 2355 W Chandler Blvd Chandler AZ 85224 (602) 786-7200	<b>Wall Street Journal</b> 420 Lexington Ave 14th Fl New York City NY 10170 (212) 808-6960
<b>microEngineering Labs</b> Box 7532 Colorado Springs CO 80933 (719) 520-5323	<b>Whole Earth Review</b> 27 Gate Five Rd Sausalito CA 94965 (415) 332-1716
<b>Nuts &amp; Volts</b> 430 Princland Court Corona, CA 91709 (909) 371-3052	<b>Wired</b> 544 2nd St 3rd Fl San Francisco CA 94107 (415) 904-0664

## DNA Computing

The human genetic code represents the ultimate hack. As you might suspect, folks are scrambling fast and furious here. The genome map itself seems the current big bucks biggie. The December 22, 1995 issue of *Science* has full secret insider details on their latest 15,000 landmark map. On pages 1919 and 1945-1954.

An alternate take on DNA possibilities appears in *Wired* for July 1995 on pages 120-124.

DNA is neat stuff. Besides building your own custom rhinopotamus, the glop makes a great chemistry kit. Seems there are four different molecules you can string together

(A,C,G, and T) into arbitrarily long digital words. You can then *simultaneously* work with these words in *billions* of parallel processes. At costs and energy levels that make a Pentium an outright joke.

For instance, a calculation that's related to the traveling salesman problem gets done a thousand times faster than the best supercomputer. Again in *Science*. November 11, 1994 this time, pages 993 and 1021-1023. Also see the follow up in *Science* for April 28, 1995. Where you'll find computers that far exceed human brain capacity.

Or, heading off in a different direction: Until recently, DNA was thought to consist of 96 percent useless "junk" and only 4 percent "good" DNA. Now, it turns out that a language – any language – has this remarkable property: Oversimplifying, the fifth most popular word gets used one-fifth as much as the most popular word. The hundredth most popular word gets used 1/100 as often. No matter whether its *Cobol* or *Swahili*.

Guess what? "Junk DNA" statistics *exactly* obey the *same* rules as *all* known human and computer languages! And the "good DNA" instead seems to obey the same rules as does efficiently compressed data! Details in *Science* for November 24,

Curiouser and curiouser..

If you want to make a real quick buck on this, just publish the pocket reference card for the DNA language.

Show us how to access a utility subroutine or two.

There's several emerging alternates to DNA computing. See *Secrets of Quantum Computing* in *Scientific American* for October 1995. And especially *Science* for September 8, 1995 on pages 1363-1364. Also see the summaries shown in [MUSE95.PDF](#) and [MUSE96.PDF](#).

## Binary Chain Codes

*Binary chain codes* are another group of repeating binary sequences. Chain codes have a remarkable property: *They are self-positioning*. Any short sample can tell you exactly where you are in the entire series.

The most obvious use for any binary chain code is in a rotary position encoder. Compared to the usual *Gray Code* position encoders, the binary chain encoder is simpler and cheaper and allows much sloppier tolerances.

Other possible uses include self-organizing geographical data bases. Topo maps, anyone?

*Photocraft* is one source of ready-to-go binary chain code encoders. I have posted a chain code intro up as my [HACK80.PDF](#). Additional technical details do appear as my [BINCHAIN.TXT](#) and [MORCHAIN.TXT](#)

What can you come up with here? ♦

*Microcomputer pioneer and guru Don Lancaster is the author of 33 books and countless articles. Don maintains a US technical helpline you'll find at (520) 428-4073, besides offering all his own books, reprints and various services.*

*US callers only, please.*

*Don has a free new catalog crammed full of his latest insider secrets waiting for you. Your best calling times are 8-5 weekdays, Mountain Standard Time.*

*Don is also the webmaster of [www.tinaja.com](http://www.tinaja.com) where a special area has been set aside for Midnight Engineering readers. You can also reach Don at *Synergetics*, Box 809, Thatcher, AZ 85552. Or email [don@tinaja.com](mailto:don@tinaja.com)*





by Don Lancaster

# Emerging Technical Opportunities V

It seems like it is once again time to review some new plays to make a buck on upcoming technology. Only on this go-round, I thought I might stay a tad closer to my home turf. Focusing on some projects around here that I am actually working on. More or less. And around which there is plenty of room for others to participate. Especially on a small scale or startup basis.

Those web links refer to files you can find on my *Guru's Lair* at [www.tinaja.com](http://www.tinaja.com) Earlier tech opportunities include [EMERGOP1.PDF](#), [EMERGOP2.PDF](#), my [EMERGOP3.PDF](#), and, yup – you guessed it, [EMERGOP4.PDF](#). An update on many of these concepts is found in [RESBN63.PDF](#)

Here's my current choice of possibilities...

## Those new Baby PIC's

The PIC microprocessor from *Microchip*, of course, is the chip of the decade. Totally blowing all the competition away with 3X speed and 3X code length advantages. While clearly eliminating any need to ever again use a 555 timer or similar "bits and pieces" kludge circuits.

Such products as the *Basic Stamp* or the *Scott Edwards Utilities* are your obvious places to start getting yourself PIC literate. Also see [RESBN54.PDF](#) on the *Pic a Peck of Pic's* library shelf for a tutorial intro.

And the *Pic Websites* page for lots of links.

But I do believe in *elegant simplicity*. I loathe to see any bloated computer system as horrendously complex and as overblown as a Basic Stamp end up as gross overkill for all of those *really* low end applications. Places where smarts have never dared go before.

Enter Microchip's new baby PIC's. Complete computers priced under a dollar and needing *zero* external support. All in an eight pin minidip package. And up to *seven* of those pins can be inputs or outputs!

A few chips in the rapidly expanding series even include internal A/D converters. But note one gotcha: The supply pins are unusual. Pin eight is *grounded*. Pin one is your *positive* supply of 3.5 or 5 volts. More in [RESBN59.PDF](#).

## Bodaciously Better BOD Bindings

Home or smaller scale *Book-on-demand* publishing has finally become a reality. Where books are produced only as they are ordered. With quality and appearance levels that now can *exceed* commercial publishing.

Along with newly unbeatable economics.

The majority of the needed tools and materials are at long last in place. The HP 5M+ is an acceptable production

printer, while the heavier 5SiMX can be a nearly ideal one. Providing genuine PostScript level II, duplexing, enhanced 600 DPI, internal hard drive, low toner refill costs, high speed, and even an 11 x 17 capability.

Improved halftoning, digital cameras, and video capture cards have finally "solved" the photo hassles. While the *Capture* feature of *Adobe Acrobat* eliminates rekeying and layout for most older printed material. That brand new MD-2010 is an unbelievably low cost (\$390 street) dye sub printer from *Alps* which nicely (but slowly) does superb full color covers. Even foil effects.

The only tiny oint in the flyment is the ongoing lack of a simple, cheap, and effective binding system. Giving you a true perfect bind, printed spines and infinite flexibility in cover material choices and colors. And indistinguishable from the "real" binding of a "real" book.

Obvious alternatives here include that non-perfect and not-quite-professional *Personal Velobinder*; those thermal glue *Unibind* covers; the *Pelsar* and *Pentabind* glue insert systems again from *Unibind*, or biting the bullet and going with a pricey printshop *BindFast 5* from *Standard*.

*Planax* has some very interesting and innovative partial BOD binding solutions. But only with ridiculously high "slipped a decimal point" prices. For instance, they have a very strong cold glue process which rapidly sets up (half a minute) through a dewatering-under-pressure chemical reaction. They have got intriguing peel-and-stick hot glue strips. And resell the *Otabind* lay-flat system. But their *Otabind* license costs thousands of dollars.

Instead, how about this simple and devastatingly useful BOD product: Take a release sheet and apply a very wimpy temporary adhesive to it. In the *Post-it* class. Then put down a thicker layer of a good hot glue suitable for normal bookbinding. Then perforate the glue into one-eighth inch wide strips. Retail it for a nickel a strip or \$3.50 a sheet. Not a bad markup for a dime or two worth of materials.

Or maybe provide the two-component glue on rolls in several widths. Scotch tape style.

Next, pick a suitable cover material and run it through the Alps printer. Laying down full colors and foil effects as needed. The Alps printer easily handles ten mil thick stock. Alternately, print thinner and fancier stock and apply white peel-and-stick label stock to thicken it.

Then score the stock and then laminate it with some non-gloss and lay-flat material. Scoring could get done by hand, with a *LithoPerf* strip, or by cloning one of those manual scoring machines you'll find at *Computer Shopper*

or over in *Quick Printing* magazine.

Peel off enough "eighths" of glue from your strip and stick them to the proper position inside your cover. Place the text inside the cover. Crease it along the score lines. Pop the whole thing into a Unibind toaster. Wait thirty seconds. Whomp the book square. And you are home free.

This entire "bind a book for a buck" market is up for grabs. Nobody, but nobody, is yet addressing this crucial and crying need. Useful printshop resources here include *Printer's Hotline*, *Printer's Shareware*, *Horsetrader*, and *California Printer*. Much on this in my *Book-on-demand* resource kit and on the [BOD](#) library shelf.

### Linearized Phase Controls

What could you do with a cheap, very efficient and gain stable 60 Hertz linear power amplifier? Well, for openers, servos, motion controls, and psychedelic lighting. Along with whole new worlds of energy conservation apps.

Except for one tiny detail, any plain old lamp dimmer can come close. Take a triac or other ac switch and turn it on someplace in each ac half cycle. Hit it late in the cycle and you'll get low power. Mid cycle gives you half power. While early triggering gives you nearly full power. The *phase shift* from each zero crossing sets output power.

The only problem is that the phase angle versus power current curve is highly nonlinear. Owing to there being far less energy in the "corners" of a half sinewave than at its peak. But these days, this is easy to fix. Simply use *table lookup* to digitally *correct* the phase delay.

A trivial task for a baby PIC.

For instance, table lookup might give you linear *current* versus your input voltage. For psychedelic light apps or motion control. A different table can give you linear *power* versus input voltage. Perhaps to conveniently dial in the wattage of a soldering iron. Specialized tables can also correct for load nonlinearities (such as low lamp brightness at low current), or even do pseudorandom effects that can simulate a candle flame.

Another largely unexplored possibility is to let the phase be controlled and corrected over an *entire* cycle, giving you a linear and bipolar variable voltage power source.

More on these concepts are found in [MUSE108.PDF](#) and [MUSE109.PDF](#).

### Three Phase Magic Sinewaves

*Magic sinewaves* are my recently discovered ultra-long sequences of repeating ones and zeros. They are used to synthesize high power sinewaves for induction motor speed controls, for electric autos, solar panels, inverters, power quality, and for home energy efficiency improvers. Magic sinewaves can offer astoundingly low distortions combined with precisely controllable amplitudes.

Compared to older PWM methods, magic sinewaves are more efficient, far more microcontroller friendly, and run much cooler. Because of far fewer switching events and significantly less high frequency energy.

In general, three phase power systems are preferred for heavier industrial loads. Owing to their continuous power, simple reversibility, lower vibration, and easy rectification. Any magic sinewave you can use for single phase loads can also be used for three phase systems. But *only* when you are willing to use six half drivers and individually access

each end of each phase winding.

Both of which are real world no-no's.

So, a special class of three phase magic sinewaves is needed. Ones which let you use normal delta or wye loads. Needing only three access points. And three half drivers.

It turns out that *any magic sinewave that has a precisely zero third harmonic will end up three phase friendly*. There thus are far fewer (trillions instead of zillions) delta friendly magic sinewaves. These are much harder to find and have other minor restrictions. But they definitely do exist. And can offer outstanding efficiencies.

More on the [Magic Sinewave](#) shelf of [www.tinaja.com](#). Especially [MSINPROP.PDF](#). And for an introduction to the three phase magic sinewaves, see [MUSE101.PDF](#). Seminars and consulting are also offered by [Synergetics](#).

### New Directions for PostScript

Needless to say, I've long been a fan of PostScript. First and foremost, as a really fine general purpose computing language. And secondarily to dirty up otherwise clean sheets of paper. Usually as a minor afterthought. There's some incredibly exciting new things coming down in the PostScript arena today.

For instance, we now have got [Adobe Acrobat 3.0](#). An extremely net-friendly way to distribute online documents. One that gives you precise control of exactly what your end viewer will see. In a virtually unlimited variety of fonts, artwork, text, photos, animation, movies, sound, and hot links. And including such bells and whistles as ultra-legible text smoothing, byte range retrieval that quickly gives you one page of a lengthy doc, video wipes or fades, and even an instant magnifier. While producing hard copy on just about any printer. Using free readers.

We now do have reasonable methods for running display PostScript or PostScript-as-language on a PC host. One is to use the public domain [GhostScript](#) shareware. A second and elegant method is to use Adobe's own [Distiller](#) as a general purpose and host based computer. The Distiller is included in the commercial Acrobat package.

Distiller 3.0 can be used as a general purpose PostScript computer in many ways: To generate printable .PDF files. To return data values and such to .LOG files. To directly read, modify, or write disk files. To output comm data. Or to perform other computer control tasks.

Some examples of the type of computation that Distiller does extremely well are web site analysis ([WEBSITAN.PS](#)); rms power calculations ([FINDRMS.PS](#)); font format shifts ([PFA2PFB.PS](#)) or ([PFB2PFA.PS](#)); linear equation solution ([LINEAREQ.PS](#)); Fourier Series analysis ([FINDFOUR.PS](#)); url embedment ([URLINDOC.PS](#)); generating microwave Smith Charts ([SMITHCHT.PS](#)), or even performing a fully automatic document colorization ([COLORIZ2.PS](#)).

Adobe is now addressing the needs of the disabled with their [Access](#) program. By using Acrobat threads to extract content for oversize text or speech conversion.

PostScript now edits video beautifully. One pioneer in this area is [Videonics](#) with their new [PowerScript](#) PS-1000. Which turns those incredible tools, outstanding fonts, and raw power of PostScript loose in an animated character generator. PostScript traditionally has lacked the crucial *alpha* or *transparency* channel. Videonics' brilliant new workaround is to use PostScript's CMYK space and simply

## EMERGING RESOURCE TOOLS

**Adobe Acrobat System**  
1585 Charleston Rd  
Mountain View CA 94039  
(800) 833-6687

**Alps Electric**  
3553 North First Street  
San Jose CA 95134  
(408) 432-6000

**California Printers**  
PO Box 11766  
Santa Ana CA 92711  
(714) 838-9401

**Scott Edwards**  
964 Cactus Wren Lane  
Sierra Vista AZ 85635  
(520) 459-4802

**Horsetrader**  
PO Box 11712  
Santa Ana CA 92711  
(714) 734-8400

**Litho-Perf/HS Boyd**  
PO Box 581117  
Tulsa OK 74112  
(918) 835-9359

**Microchip Technology**  
2355 W Chandler Blvd  
Chandler AZ 85224  
(602) 786-7200

**Parallax Basic Stamp**  
3805 Atherton Rd #102  
Rocklin CA 95765  
(916) 624-8333

**Planax North America**  
15 E 26th St #1908  
New York NY 10010  
(212) 532-1988

**Printer's Hot Line**  
PO Box 1709  
Fort Dodge IA 50501  
(800) 950-7746

**Printer's Shareware**  
5019 W Lovers Ln  
Dallas TX 75209  
(214) 350-1902

**Printers Shopper**  
PO Drawer 1056  
Chula Vista CA 92012  
(800) 854-2911

**Quick Printing**  
1680 SW Bayshore Blvd  
Port St Lucie FL 34984  
(407) 879-6666

**Standard Bind-Fast**  
10 Connector Rd  
Andover MA 01810  
(800) 526-4774

**Synergetics**  
Box 809  
Thatcher AZ 85552  
(520) 428-4073

**Unibind/Pelsaer**  
4125 Prospect Dr  
Carmichael CA 95608  
(916) 967-6401

**Velo-Bind**  
650 Almanor Ave  
Sunnyvale CA 94086  
(800) 538-1798

**Videonics**  
1370 Dell Avenue  
Campbell CA 95008  
(408) 866-8300

redefine "K" as transparency, rather than black.

See [MUSE110.PDF](#) for details.

Ah yes, robotics. I like to call a *flutterwumper* most any machine that moves while chomping or spitting. Anything from a Santa Claus machine to a pc drill to an embroidery setup to an animation stand to a laser cutter to a signmaker. Host-based PostScript can ridiculously simplify all these devices. Simply convert PostScript output to any ultra low level stepping language, and the amount of smarts needed in your machine reduces to zilch. And is easily crammed into any old PIC. Full details appear in [FLUTWUMP.PDF](#) and [FLUTOOLS.PS](#).

More info on these PostScript opporknockities are on the *Acrobat*, *Flutterwumper*, and *PostScript* library shelves of [www.tinaja.com](#) Key PostScript books appear in my nearby *Synergetics* ad. Let's hear from you. ♦

---

*Microcomputer pioneer and guru Don Lancaster is the author of 33 books and countless articles. Don maintains a US technical helpline you'll find at (520) 428-4073, besides offering all his own books, reprints and various services.*

*Don has a free new catalog crammed full of his latest insider secrets waiting for you. Your best calling times are 8-5 weekdays, Mountain Standard Time.*

*Don is also the webmaster of [www.tinaja.com](#) where a special area has been set aside for Midnight Engineering readers. You can also reach Don at his *Synergetics*, Box 809, Thatcher, AZ 85552. Or email [don@tinaja.com](mailto:don@tinaja.com)*



Superb aviation history book  
 A new RGB to NTSC encoder  
 Lamps and lighting efficiency  
 Emerging ultra-fast computers  
 Product development concepts

I just got a helpline call from an "inventor" trying to "protect" a "new" auto headlight idea. To stop "Detroit" from stealing it.

I've never heard of "Detroit" ever paying any outsider for any untested, undeveloped, or unproven idea.

Instead, "Detroit" buys parts from suppliers and bolts them together to make cars. They are in the process of outsourcing much of their product engineering. They are significantly reducing their number of suppliers. And holding them to the tightest of razor thin margins.

Uh, strike one.

Illumination engineering is one of the very few things that Fortune 500 companies happen to do very well. A multi-skill project team approach is usually required, combined with ray tracing computers, arcane production engineering, and outstanding access to the world's research base.

So, those big boys clearly have an unbeatable home turf advantage here.

For strike two.

Your really big issue on all future headlights is efficiency. Because of downsizing in general and electric or hybrid cars in particular. Anything less than 100 Lumens per Watt won't hack it. You can bet that tomorrow's headlights will most definitely not be based on a heated filament.

I got the impression the caller was not a member of the SAE. Nor did he seem to be at all into trade journals or online literacy. He seemed to feel that car headlamp efficiency was "not important." And apparently did not have the slightest idea how woefully inefficient his new design was. For a self-inflicted swing and a miss for strike three.

### A Realistic Alternative

Let us assume that you genuinely feel that you do have a great "new" headlamp design. What could you do that works out in the real world? Step one is to get yourself trade journal, association, and online literate. To make sure you aren't talking about a product that's been sold for decades.

Or one that long ago fell off the shelf because of inherent problems.

Step two is to ask yourself "Who is it that (A) likes bright headlights, and (B) has their own wallet in their own back pocket?"

Well, out here on my sand dune, the answer is glaringly obvious: 4WD desert off-roaders. To these folks, a "map" light is 50,000 candelpower.

And a "running" light can vaporize troublesome boulders at 75 paces.

On low beam.

So, firstoff, you would have a few four wheelers critique your design. If it is any good, you then let the local 4WD club beta test it. Once you have your tested and proven product well received, you sell a few at regional meets. Then you publish it in all the offroad mags.

Next you seek out one or more of those off road lighting outfits. *K.C. Manufacturing* is but one of the name brand biggies out here. Competitors include *Dick Cepek*, *Hella*, *Explorer*, and *Piaa* corp.

But be sure to remember the key insider secret rule for all successful new product development: *They must come to you.* And never vice versa.

Do note that you are not selling an idea. Ideas are worth ten cents a bale in ten bale lots. You are instead now offering a proven, in-demand, and a ready to manufacture product. here you have already completed most of the high risk steps.

More on becoming a purveyor of risk reduction in [RISKDOWN.PDF](#) on [www.tinaja.com](http://www.tinaja.com) And much more in general on idea development in my *Blatant Opportunist* and my *Case Against Patents* packages.

### A RGB to NTSC Converter

I get all sorts of helpline calls from folks who want to use an ordinary color tv set for their computer output. Preferably via the antenna input.

Instead of buying a pricey high resolution RGB monitor. Well, these days, yew jest caint get there from here. The tv resolution is too low and

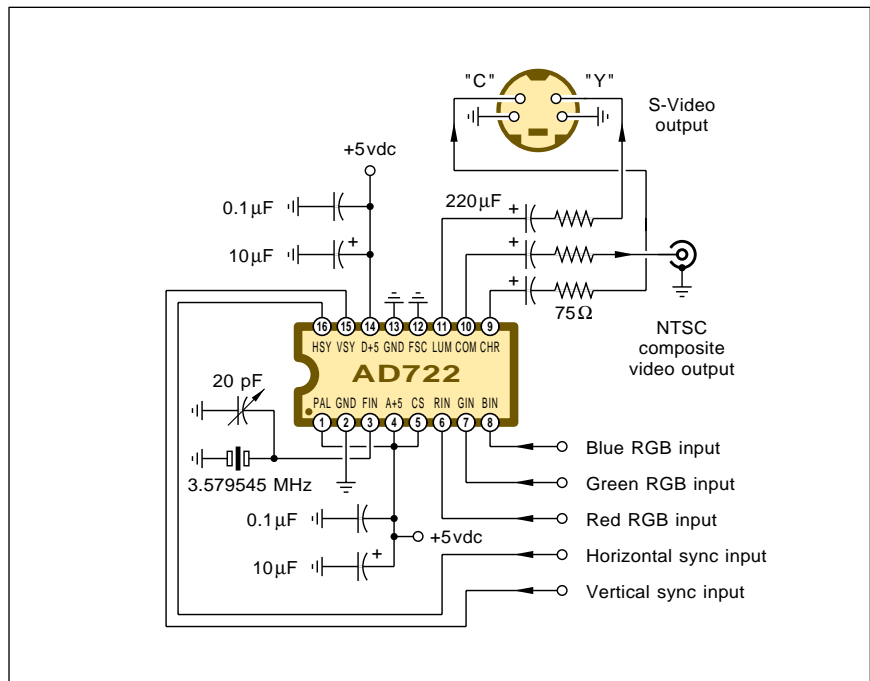

Fig. 1 – A NEW \$8 RGB TO NTSC CONVERTER CIRCUIT. But note that your sweep rates, interlace, overscan, and your program content must all be made tv-compatible if you want useful results.



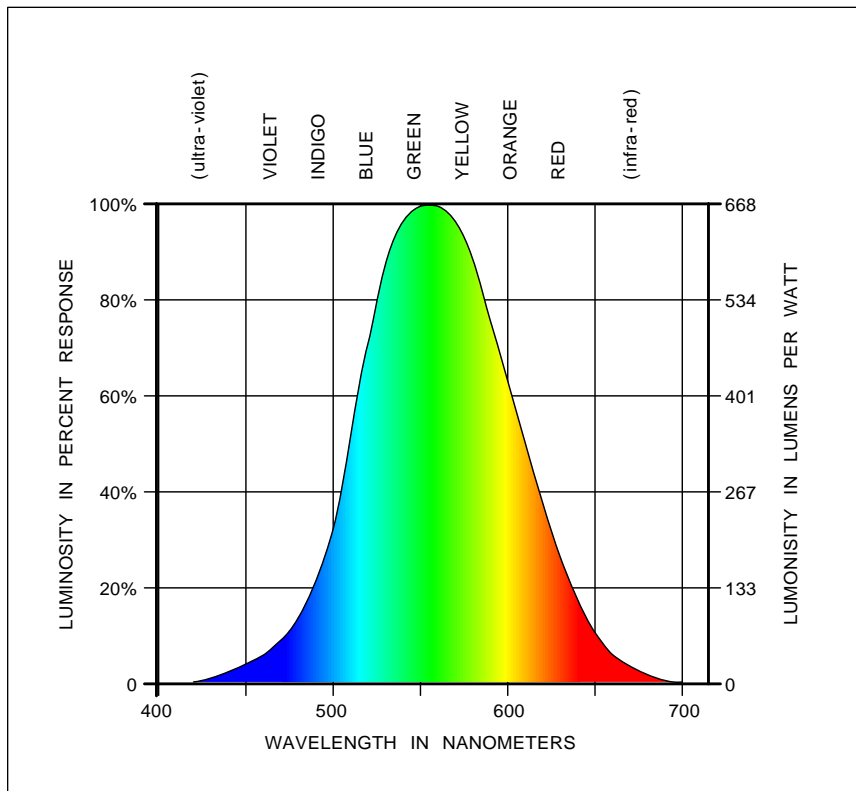

Fig. 2 – THE LUMINOSITY RESPONSE of the human eye varies with color. It is highest for a yellow-green and lower for red or blue. Thus, white light sources are inherently less efficient than lime green ones.

the computer screen info content is way too high. Why do you suppose they went to all of those fancy hires monitors in the first place?

No matter what you do, there is *no way* you that can display "ordinary" modern computer color spreadsheet or word processor output by rf entry on an unmodified television! All you will get is a hopelessly smeared and violently flickering illegible mess.

On the other hand, if you design your computer screen *content* to be consistent with what your tv set can reasonably and intelligently handle, then you certainly can display it. At least after format conversion.

Thus, computers might definitely get used for video titling, for *large* screen data or text, for video editing, for "slide show" presentations, or for abstract art effects.

*Analog Devices* has just come up with a greatly improved and easy to use AD722 single chip RGB to NTSC encoder. I've shown a typical lashup in figure one. You can use this chip to convert *already tv viewable* RGB computer output into signals a tv set

can understand. But you *can not* use this (or any other scheme I know of) to let a tv replace a hires monitor.

Let us review some fundamentals. The NTSC, or *Never the Same Color* system is an American broadcasting standard. It was conjured up decades ago to cram color information in to the same rf bandwidth as the mono signal. This was done by creating a new color *subcarrier* frequency of 3.579545 MegaHertz.

This special frequency allows the sampled color spectrum to magically "interleave" with the black and white comb spectrum on the same channel.

Many compromises were involved with NTSC. Set mostly by technology limits at the time. And the need to be backward compatible with old tv's.

Thus, the reasons why rf entry on a color tv cannot display computer data include (A) its far too low horizontal and vertical sync rates, (B) severely limited resolution that prevents more than a few dozen color changes on any screen line, (C) its interlace that badly flickers small characters, and (D) overscan that hides corners.

If you are able to resolve *all* of the problems, then building an RGB to NTSC coverter makes sense.

Otherwise, it does not.

Briefly reviewing, an RGB system has its video on three separate red, blue and green lines. An extra line or two gets output for sync. Or else the sync gets combined onto your green channel. RGB says *nothing* about any standards or scan rates. But they are typically far higher than any tv can accept. Ridiculously so.

NTSC instead combines all of the picture information into a baseband black and white *luminance* signal and a color *chrominance* subcarrier. The chroma channel applies a quadrature modulator for a color phase.

NTSC demands a pair of interlaced 262-1/2 line *fields* at a vertical sync rate of 59.96 Hertz. The horizontal scan rate is 15,735 Hertz. Interlace reduces flicker *only* when adjacent lines are fairly similar. Since this is *never* the case with small dot matrix characters, *interlace flickers badly on all small text*.

The NTSC signal will be purposely overscanned. Gruesomely so on older sets, Wrapping the picture around the side of the tube guarantees there will be no ugly black side stripes.

Thus *all* NTSC programming *must* guarantee that the useful stuff always ends up *only* in the *center*.

The chip is easy to use. You first apply the usual +5 volts at 30 mils. Also connect pin one to +5 to select a NTSC instead of the PAL standard. The RGB outputs go directly to the red, green, and blue inputs. Three outputs are provided: the composite video, a Y luminance output, and a C chrominance output. These latter two outputs can optionally get routed to a S-video connector.

In addition, you have to get sync and the stable color subcarrier from somewhere. You can input horizontal and vertical sync on separate pins. Or else put composite sync into pin 16 while making pin 15 positive.

If you have a 4X color subcarrier clock available, by all means use it, inputting to pin 3. If not, you hang a stock *parallel resonant* color burst crystal from this pin to ground. Note that resynchronizing to a local crystal may degrade your results.

A logic high on pin 12 selects the

4X subcarrier mode, a low picks 1X.

Be sure to carefully read the data sheet. There are several nasty gotchas to getting this chip to interact with VGA and other standards.

Conventional tv receivers require a chroma *delay line* to compensate for color shifts; a circuit equivalent to a delay line is *included* on chip so the results end up nearly identical to a broadcast signal.

The outputs are all at *twice* normal amplitude, letting you directly drive a 75Ω reverse terminated load.

Most VGA sources have provision for control by software. Once again, your sync rates and picture content *must* be NTSC compatible ahead of time. Or you'll get useless results.

### Lighting Fundamentals

If you pick up any plain old 60 watt light bulb, it is likely to be rated around 850 *Lumens*. That sounds like a bunch. Until you find out what a Lumen *really* is. Then you discover how badly you've been ripped off.

Well, a *Lumen* is a measure of the *total output light power*. How many Watts of light you will get back after gathering together all the output from all directions. (Er – usually anyway. Some narrow beam spotlights cheat and use "effective Lumens" instead. Sort of like antenna gain.)

Being a unit of power, there is a relationship between the output light *Lumens* and input electrical *Watts*. This relationship also depends on the eye's sensitivity to colors. The eye responds with the *luminosity curve* shown in figure two. Eye sensitivity is highest in the yellow-green.

A Lumen is defined as 0.001496 Watts of yellow-green light. Or 668.5 Lumens per Watt. A 100% efficient 60 Watt yellow-green light bulb can thus produce 40,110 Lumens.

Which means your plain old light bulb has a yellow-green efficiency of a mere 2.1%! When the other colors are considered, your total barely gets up to seven percent or so. A rating of *fourteen* Lumens per Watt. Caused by nearly all the input energy getting converted into useless heat.

The first obvious try at efficiency improvement is to operate the lamp hotter. This works, but dramatically reduces lamp life. For a work-around, the bulb folks have recently gone to a

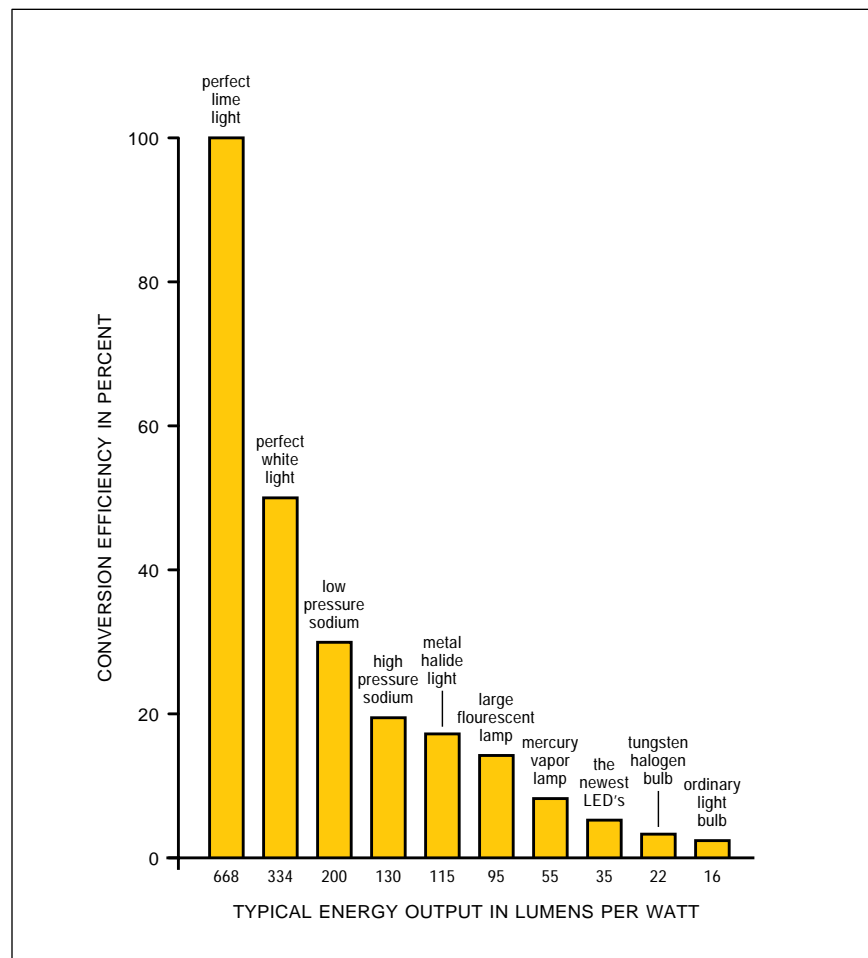

Fig. 3 – EFFICIENCY RATINGS for several emerging lamp technologies. Note that ordinary incandescent light bulbs are utterly awful.

*Halogen Cycle*. Once known as the "Quartz-Iodine" approach.

You still do have an incandescent lamp here. That "quartz" part means the actual bulb temperature can be higher without shattering. And that "iodine" vapor part sets up a magic cycle that grabs any tungsten that got boiled off of the filament during hot times. Forming a tungsten iodide gas which is only stable when hot. The gas then redeposits the tungsten right back onto the filament during cold shutdown times.

All of which gives you a modest improvement in efficiency. Around fifteen percent better for a 52 Watt Halogen replacement lamp. But the higher initial costs will eat into your energy savings. These do last twice as long, though.

The larger Halogen lamps can get up to 22 Lumens per Watt. Two big gotchas here: You must *never* touch

the bulb on these. The fingerprint oil causes a cold spot which can shatter the glass. And the lamps must *not* be continuously turned on and off. The halogen cycle only operates properly when the lamp remains on for hours at a time. With lots of cooling time between uses.

### Improving Efficiency

Actually, the correct term here is *efficacy*, since the output energy is in a different form than the input. There are bunches of lamp technologies far more efficient than any incandescent. Figure three shows us how all these alternates compare.

Let's look at a few candidates...

**Light emitting diodes**– Surprisingly, many newer LED's are actually *more* efficient than incandescents. Besides lasting a lot longer. Cavers have long ago picked up on all of those orange



LAMP AND LIGHTING RESOURCES

**Advance Transformer**  
10275 W Higgins Road  
Rosemont IL 60018  
(708) 390-5000

**EPRI Journal**  
PO Box 10412  
Palo Alto CA 94303  
(415) 855-2000

**Hewlett-Packard**  
PO Box 10301  
Palo Alto CA 94303  
(415) 857-1501

**Lighting Research Institute**  
120 Wall Street 19th Floor  
New York NY 10005  
(212) 248-5014

**BHK**  
1000 S Magnolia Avenue  
Monrovia CA 91016  
(818) 357-9667

**Explorer**  
14100 Kingsley Drive  
Gardena CA 90249  
(310) 719-7285

**Home Power**  
PO Box 520  
Ashland OR 97520  
(916) 475-3179

**Loctite Luminescent**  
Etna Road  
Lebanon NH  
(603) 448-3444

**Bulbman**  
PO Box 2918  
Reno NV 89505  
(800) 648-1163

**Gilway Technical Lamp**  
800 W Cummings Park  
Woburn MA 01801  
(617) 935-4442

**IESNA**  
120 Wall Street 17th Fl  
New York NY 10005  
(212) 248-5000

**Neon News**  
PO Box 668  
Beaverton OR 97006  
(808) 967-7648

**Bulbtronics**  
45 Banfi Place  
Farmingdale NY  
(516)249-2272

**Grainger**  
2738 Fulton St  
Chicago IL 60612  
(312) 638-0536

**JKL Components**  
13343 Paxton St  
Pacomia CA 91331  
(800) 421-7244

**PIAA Corp**  
15370 SW Millikin Way  
Beaverton OR 97006  
(800) 525-7422

**Carley**  
1502 W 228th Street  
Torrance CA 90501  
(213) 325-8474

**Gray**  
4415 Indianapolis Blvd  
E Chicago IL 46312  
(800) 238-2244

**KC Lites**  
PO Box 155  
Williams AZ 86046  
(800) 528-0950

**Real Goods**  
966 Mazzoni St  
Ukiah CA 95482  
(800) 762-7325

**Dick Cepek**  
17000 Kingsview Avenue  
Carson CA 90746  
(800) 992-3735

**Hella**  
201 Kelly Drive  
Peachtree City GA 30269  
(800) 247-5924

**Lighting Design & Apps**  
120 Wall Street 17th Fl  
New York NY 10005  
(212) 248-5000

**Welch Allyn**  
4619 Jordan Road  
Skaneateles Falls NY 13153  
(315) 685-4275

superbright *Hewlett-Packard* diodes as backup light sources. And Detroit is now heavily into LED tail lights. Both because of their longer life and their "instant on" feature. The latter translates to some *twenty feet* of extra safety margin at thruway speeds.

There is no fundamental physical limit restricting LED efficiency. It is more economics, material science, visual coupling, total output, and a poor performance in the blue that is holding things up.

**Neon Lamps**– These are just a pair of electrodes in a glass enclosure that is filled with some inert gas such as neon (orange), xenon (blue), carbon dioxide (white), helium (purple), or mercury (green). A current causes a glow discharge and output light.

These are potentially very efficient "cold light" sources. The Lumens per Watt depends on the color. Output power is normally low. High voltages are always involved. Today, "neon" tubes are used for advertising.

More on these in *Neon News*, *POP Design*, *Sign Craft* or *Sign Business* trade magazines.

**Electroluminescent Panels**– This is another "cold light" source. Basically a capacitor with a phosphor on one electrode. A high ac voltage (100-400 volts) is applied, whose field strength excites the phosphor. Many colors, including white. A medium green is usually the brightest.

Best results are obtained at mid audio frequencies. Total light output is low, and the lousy power factor makes for big time drive problems. Your brightness drops significantly with time and contamination. Not much seems to be happening lately in new developments here.

*Loctite Luminescent* is one info and parts source.

**Fluorescents**– A fluorescent lamp has a much better efficiency than any incandescent. Up to 100 Lumens per Watt. A fluorescent lamp works in two stages. First an ionized plasma discharge generates strong and narrow band ultraviolet light.

That invisible ultraviolet light then impinges on a *phosphor* which will downconvert most energy radiation into the visible range.

Because these are current operated, a regulator in the form of a magnetic or electronic *ballast* is required. Electronic ballasts do offer *electrical* efficiencies of 85 percent and higher. They also can excite the phosphor at higher frequencies. Both for more light and lower flicker. Dimming is a brand new electronic option.

**RF Fluorescents**– A new scheme where a phosphor is directly excited by a radio frequency source. While it is too new to tell, the efficiency should be "high". If the costs, circuit complexity and rfi problems can be overcome. Watch for overblown hype

NEED HELP?

Phone or write all your US Tech Musings questions to:

Don Lancaster  
Synergetics  
Box 809-EN  
Thatcher, AZ, 85552  
(520) 428-4073

US email: [don@tinaja.com](mailto:don@tinaja.com)  
Web page: [www.tinaja.com](http://www.tinaja.com)

and investment scams on these.

**Mercury Vapor lamps**— These are just a tiny blob of mercury and two electrodes. The mercury gets heated somehow. Either by direct arcing, or by neon or some other gas discharge warming it. The vapor supports a current limited arc discharge. They produce a bluish white light. The efficiency is 50 Lumens per Watt.

Because all these lamps produce a dangerous amount of short wave uv, safety filters are a must. Their life is extremely long at 24,000 hours. Color rendition is only poor to fair. I get the impression their popularity has clearly peaked.

**Arc lamps**— Those old carbon arc lamps offered very high brightness. Their efficiency is not half bad at 120 Lumens per Watt. But the traditional designs consumed carbon rods and needed continuous adjustment. And they did not scale down well.

The *Welch-Allyn* folks have come up with a newer sealed variant called a *short-arc* lamp. This 21 watt point source device offers 75 Lumens per Watt and is intended for scientific and fiber optic apps. A special ballast is needed. Because it is as much as 4X more efficient than halogens, this seems ideal for battery powered apps.

But pretty expensive, though.

**Metal Halide lamps**— By far your most popular bulb for commercial and industrial lighting, these new designs offer efficiencies as high as 125 Lumens per Watt and good color rendition. Life can approach 20,000 hours. Typical sizes vary from 25 on up to 2000 watts. Special ballasts are required, as is an ultra violet safety filter. The filter is often built into the glass itself. Expect to see these move into home and vehicular lighting.

I'd guess that these would be the obvious choice for most future auto headlights. Until something better comes along.

**Low Pressure Sodium**— A clear cut efficiency winner at 200 Lumens per watt, these "street lamps" do offer extreme life, low running costs and outstanding nighttime visual acuity. Astronomers love them because they can dramatically minimize any visual pollution. Sadly, their distinctive orange color gives a mesmerizingly

awful color rendition. Sizes as small as 18 watts are newly offered.

**High Pressure Sodium**— Another sodium lamp variant, this one trades off extreme efficiency for a greatly improved color rendition. At low gas pressures, the emission takes place in distinct spectral lines. As pressure increases, the lines first broaden, and then become more continuous. These can offer 120 Lumens per Watt with no ultraviolet filter hassles.

A 10,000 hour life is common. The sizes range from 35 up to 1000 watts. The cost is around \$90 in singles. Mercury vapor ballasts can be used. Most operate in any position.

### Some Lighting Resources

I have gathered up a few lighting resources for you as this month's sidebar. Besides those I have already mentioned, a few deserve comment.

*IESNA* seems to be the main trade association. They publish a *Lighting Design and Application* magazine plus a technical research journal. There is also a *Lighting Research Institute* in the same building.

The *EPRI* journal is by the *Electric Power Research Institute*. Who offer fine reference materials.

The leading industrial source for lamps is *Grainger*. The graphics arts lamps are usually sold by *Bulbman*, *Bulbtronix*, *Gray*, and *HID Systems*, among many others.

Two manufacturers of the smaller lamps are *Gilway* and *Carley*. *JKL* is a good source for low cost miniature fluorescent lamps, while *BHK* offers specialized uv lamps. *Advance* is the leading ballast supplier.

*Home Power* is a fine magazine for off grid lighting apps. A high profile lamp and alternate energy supplier is *Real Goods Trading*.

Please let me know if I missed any of your favorite sources here. A free *Incredible Secret Money Machine II* for your trouble.

### A Great Read

I was genuinely impressed by *The Shoulders of Giants*, a history of early aviation. Written by Phil Scott and published by *Helix Books*.

There was a government aviation fiasco at the time of Kitty Hawk that did cost hundreds of times more. The

## new from DON LANCASTER

### ACTIVE FILTER COOKBOOK

The sixteenth (!) printing of Don's bible on analog op-amp lowpass, bandpass, and highpass active filters. De-mystified instant designs. **\$28.50**

### CMOS AND TTL COOKBOOKS

Millions of copies in print worldwide. THE two books for digital integrated circuit fundamentals. About as hands-on as you can get. **\$28.50 each.**

### INCREDIBLE SECRET MONEY MACHINE II

Updated 2nd edition of Don's classic on setting up your own technical or craft venture. **\$18.50**

### LANCASTER CLASSICS LIBRARY

Don's best early stuff at a bargain price. Includes the CMOS Cookbook, The TTL Cookbook, Active Filter Cookbook, PostScript video, Case Against Patents, Incredible Secret Money Machine II, and Hardware Hacker II reprints. **\$119.50**

### LOTS OF OTHER GOODIES

Ask the Guru I or II or III	\$24.50
Hardware Hacker II, III or IV	\$24.50
Micro Cookbook I	\$19.50
PostScript Beginner Stuff	\$29.50
PostScript Show and Tell	\$29.50
Intro to PostScript Video	\$29.50
PostScript Reference II	\$34.50
PostScript Tutorial/Cookbook	\$22.50
PostScript by Example	\$32.50
Understanding PS Programming	\$29.50
PostScript: A Visual Approach	\$22.50
PostScript Program Design	\$24.50
Thinking in PostScript	\$22.50
LaserWriter Reference	\$19.50
Type 1 Font Format	\$16.50
Acrobat Reference	\$24.50
Whole works (all PostScript)	\$380.00
Synergetics Surplus Catalog	FREE
Technical Insider Secrets	FREE

### POSTSCRIPT SECRETS

A Book/Disk combination crammed full of free fonts, insider resources, utilities, publications, workarounds, fontgrabbing, more. For most any PostScript printer. Mac or PC format. **\$29.50**

### BOOK-ON-DEMAND PUB KIT

Ongoing details on Book-on-demand publishing, a new method of producing books only when and as ordered. Reprints, sources, samples. **\$39.50**

### THE CASE AGAINST PATENTS

For most individuals, patents are virtually certain to result in a net loss of sanity, energy, time, and money. This reprint set shows you Don's tested and proven real-world alternatives. **\$28.50**

### BLATANT OPPORTUNIST I

The reprints from all Don's Midnight Engineering columns. Includes a broad range of real world, proven coverage on small scale technical startup ventures. Stuff you can use right now. **\$24.50**

### RESOURCE BIN I

A complete collection of all Don's Nuts & Volts columns to date, including a new index and his master names and numbers list. **\$24.50**

### FREE SAMPLES

Check Don's Guru's Lair at <http://www.linaja.com> for interactive catalogs and online samples of Don's unique products. Searchable reprints and reference resources, too. Tech help, hot links to cool sites, consultants. email: [don@linaja.com](mailto:don@linaja.com)

FREE US VOICE HELPLINE

VISA/MC

**SYNERGETICS**  
Box 809-NV  
Thatcher, AZ 85552  
(520) 428-4073

**NAMES AND NUMBERS**

**Analog Devices**

PO Box 9106  
Norwood MA 02062  
(617) 329-4700

**Atmel**

2125 O'Nel Drive  
San Jose CA 95131  
(408) 441-0311

**Flexible Circuits**

6195 Corte del Cedro #110  
Carlsbad CA 92009  
(619) 431-2869

**Focal Press**

313 Washington Street  
Newton MA 02158  
(617) 928-2500

**GENie**

401 N Washington St  
Rockville MD 20850  
(800) 638-9636

**Helix Books**

Addison-Wesley  
Reading MA 01867  
(617) 944-3700

**Image Processing Resources**

PO Box 207  
T or C NM 87901  
(800) 735-3596

**Intel Corporation**

2200 Mission College Blvd  
Santa Clara CA 95052  
(800) 548-4725

**The Mart**

899 Presidential #110  
Richardson TX 75081  
(800) 864-1155

**P-O-P & Sign Design**

7400 Skokie Blvd  
Skokie IL 60077  
(708) 675-7400

**Power Transmission Design**

1100 Superior Avenue  
Cleveland OH 44114  
(216) 696-7648

**Riteco Supply**

12999 FM 529  
Houston TX 77041  
(713) 896-6200

**Roland Users Group**

7200 Dominion Circle  
Los Angeles CA 90040  
(213) 685-5141

**SAE**

400 Commonwealth Drive  
Warrendale PA 15096  
(412) 776-4841

**Science/AAAS**

1333 H St NW  
Washington DC 20005  
(202) 326-6400

**Sign Business**

1008 Depot Hill Office Pk  
Broomfield CO 80020  
(303) 469-0424

**SignCraft**

PO Box 06031  
Fort Myers FL 33906  
(813) 939-4644

**Siliconix/Temic**

2201 Laurelwood Road  
Santa Clara CA 95054  
(800) 554-5565

**Synergetics**

Box 809  
Thatcher AZ 85552  
(520) 428-4073

**Tiare Publications**

PO Box 493  
Lake Geneva WI 53147  
(800) 420-0579

*Application Book*. From *Siliconix*, a data book on the *Little Foot* and *Lite Foot* mini power MOSFETs. These require surprisingly little in the way of heatsinking. From *Intel* a new free CD on their full *i960 Microprocessor Electronic Library*.

Computers that can be *billions* of times faster than a Pentium (and far cheaper) are described in *Science* for September 8, 1995 on page 1363-64. One of the many options is *quantum computing*. Expanded upon on pages 140-145 of *Scientific American* for October of 1995.

*Roland* magazine is a free pub on synthesizers and related electronic music topics. They've also come up with a new *Sound Canvas*. An entire synth in a single PCMCIA card.

*Power Transmission Design* is a new trade journal on motion systems. *The Mart* is a big-time major shopper on phone parts and systems.

*Flexible Circuits Engineering* is a brand new trade journal on bendable printed circuit materials.

*Hoop Pine Plywood* is a flexible wood suitable for modelmaking and prototypes. Free samples are offered by the *Riteco Supply* folks.

The free *Media Arts Catalog* from *Focal Press* stocks hundreds of titles on everything from nonlinear editing to time codes to scriptwriting.

For high end hardware, try *Image Processing Resources*. For lighting, lenses, cameras, frame grabbers, and more. Lots of great cartoons in their free catalog.

A *BBS Radio* directory is available from *Tiare Publications*. But do note that these are the hobby listings only. That outstanding RADIO board up on *GENie* is not mentioned. Nor is any other major commercial resource.

There are lots of new opportunities in self publishing these days. For the latest and best info, check into my new *Book-on-demand Resource Kit*. Available per my *Synergetics* ad.

The usual reminders that most of those items mentioned appear in the *Names & Numbers* or in the *Lighting Resources* sidebars. Be sure to check here before you call our no-charge tech voice helpline. ♦

program only succeeded in filling the Potomac River with broken bits and pieces of planes and pilots.

The Wright Brother's patent fights clearly set US aviation back far more than their early flights ever advanced it. For decades, even.

That initial transcontinental flight

crashed so many times that only an original wing spar and most of the pilot actually ended up on the west coast. And, of course, the Red Baron failed his flight test three times.

**New Tech Lit**

From *Atmel* a new *Flash Memory*

Don Lancaster's

# RESOURCE BIN

number fifteen

## Secrets of professional prototypes.

**O**ur usual reminder here that the *Resource Bin* is now a two-way column. You can get tech help, consultant referrals and off-the-wall networking on nearly any electronic, *tinaja questing*, personal publishing, money machine, or computer topic by calling me at (602) 428-4073 weekdays 8-5 MST. I've got a free pair of insider secret resources brochures waiting for you when you call or write.

A portion of my PSRT RoundTable on *GENIE* has also been set aside for you *Nuts & Volts* readers. This is the place to go for instant tech answers. Among the many files in our library, you will find complete reprints and preprints for all of my *Resource Bin* columns. You can call (800) 638-9636 for your voice connect info.

One door closes and another opens. Last month we saw the US version of *Elector Electronics* fold. But this month the Gernsback folks (aka *Electronics Now*, *Popular Electronics*, and *Science Probe*) are newly publishing a local reissue of *Silicon Chip*, a very popular Australian hobbyist magazine. Time will tell how good a hacker resource this turns into.

### Secrets of professional appearance

Getting a new project to look decent can be a real hassle. This month, I thought I'd review some of my tricks and techniques needed for making prototypes and models that are both attractive and professional.

If you are not really into models and mechanical stuff yourself, you may want to check around and see what resources you can find locally. For instance, a neighbor who is also a retired machinist can be an extremely valuable source of low cost help and ideas. So can non-obvious sources as a trailer hitch works, a blacksmith, or an air conditioning shop.

Do you have a nearby community

college? Do they offer a *Basic Machine Shop 102* course? This can give you an unrestricted access to an incredible set of tools for a few dollars per month.

### Which tools?

I've got my own little shop I use for mechanical work. It is separate from my electronics lab. There's actually very little in it. A small but quality multi-speed drill press. Be sure yours provides a quill feed and has enough precision to put a #67 printed circuit drill exactly where you want it.

A *rotary table* is an unusual drill press accessory that I've found very useful. This basically has three cranks on it for X, Y, and rotation. Besides light milling, this table is real handy when you want to drill two or more holes a precise distance apart.

Everybody's gotta have a lathe, right? Wrong, actually. Lathes are highly overrated. But I do have an old six inch *Sears/Atlas* version, plus all its usual accessories. Plus, of course, a small grinder for the tool bits. Sadly, I have done very little with this superb machine. Possibly more coil winding than anything else.

A small circuit board shear is a must. The only reasonable choice here

**NEXT MONTH: Don looks at several ongoing robotics opportunities.**

is the twelve incher available from *Kepro*. Hint: glue some small mirrors on the table under the shear and cut things *marked side down*. This greatly improves your accuracy.

You will want several small but sturdy work tables. And, of course, a decent and somewhat largish bench vise. Non-obvious but very valuable is a small punch set. I use the *Roper Whitney XX*. This is a half ton job with

a four inch throat. It can punch up to a half inch or so in light aluminum or circuit boards. The round punches are surprisingly cheap. And even some fancy rounded rectangular punches I needed for a custom keyboard were not all that bad.

A small collection of hand tools is also useful. Among the more oddball items I find essential are an automatic center punch, a scribe, and a nibbling tool. A table mounted router can also be surprisingly versatile.

### Cases and enclosures

These days we have lots of low cost plastic cases available in a stunning variety. Even including battery cases and belt clips. While *Radio Shack* is your cheapest and most convenient source, a very wide variety of these boxes are available from *Bopla*, *Bud*, *EAI*, *Hammond*, *LMB Heeger*, *PacTec*, *Serpac*, *Vector*, and *Vero*.

Be sure to select a case that uses a modern engineering thermoplastic. There are still a few older *Bakelite* or phenolic cases kicking around. These are much harder to work with and shatter quite easily. Your usual clue here is a case that is offered only in black or dark brown.

Naturally, you'll find all sorts of case options from our various *Nuts & Volts* advertisers. At great prices.

My favorite low cost ultra rugged outdoor rated waterproof plastic case is the one offered by *Pelican Products*. This dude is ideal for a solar pump controller or a hot tub timer. And can end up fairly cheap when ordered in reasonable quantities.

I guess I've tended to build up my own enclosures, rather than buying ready-to-go ones from others. This can give you exactly what you want exactly how you want it. Custom enclosures can also be much cheaper, especially if you are going to go into limited or small volume production.

Let's look at three of my favorites. The first is the *Zero Box*....

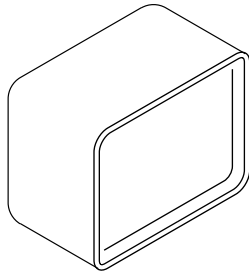

Zero boxes are simply deep drawn aluminum shells provided in a wide variety of sizes. While many of the *Zero Manufacturing* products are ultra fancy Mil-Spec offerings, their basic boxes are not all that costly.

You can use the box on its side as shown here for traditional electronic projects. Such as an audio oscillator or a color tv pattern generator. Or you can use a shorter box on its back for flat projects such as an stereo mixer or a psychedelic lighting control.

Many Zero boxes are available with optional tight fitting inside or outside lids. A recessed inside lid is shown above. A *MetalPhoto* dialplate also works beautifully here.

Zero also offers a nice gray epoxy splatter finish as an extra cost option. Being aluminum, these boxes also can anodize beautifully in dozens of bright colors. Check your local plating shop for more details.

Do note that any sealed box can let internal parts overheat badly. Limit these boxes to lower power systems. Use the box itself for a heatsink. Or add external heatsink extrusions. Or provide enough ventilation. Vented hole plugs are available at low cost from *Stimpson*.

My second favorite prototyping box is the *clamshell*...

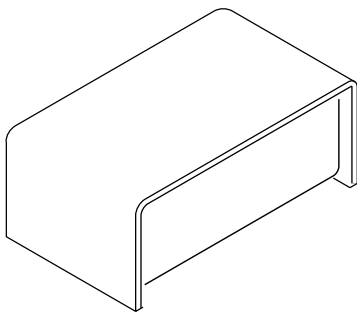

What you have here is simply two "U" shaped pieces of aluminum or other sheet metal. The bottom piece can be finished by a heavy textured sanding followed by a clear epoxy or urethane overcoat. The top cover has a fake Naugahyde vinyl glued on.

Don't feel bad about all of those cute little Nauga pups that gave their life for your project. The ones with those big, sad eyes. The pups are all bludgeoned at an early age and never knew what hit them. Besides, there are at least a dozen or two of them left. At last count.

Any accessories such as a carrying handle or a "tilt-up" base stand are conveniently available. One trick I've used for a comfortable handle grip is to simply use a many-turn vinyl wrap over a heavy aluminum bracket.

Two or more ordinary "L" brackets can be used to hold bottom to top. Knobs for tilt-up bases and such are offered through *Dimco-Gray*. *Keystone Electronics* is one low cost source for case hardware. Other useful sources do include *Bead Manufacturing*, *Micro Plastics*, and *ITW/Fastex*.

For model and display materials, *FomeBords* is the source to beat. A final resource for just about all case and hardware materials is *Small Parts*.

My third favorite is the *wooden end rail ploy*...

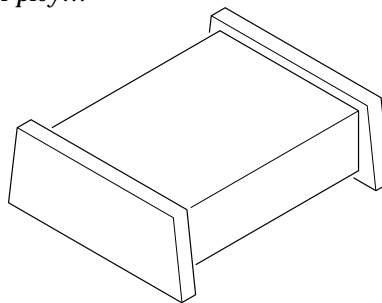

Your main chassis is simply a bent piece of aluminum. Again finished by a heavy sanding and a clear overcoat. The plain old bends can be done on any sheet metal brake. Your end rails can be an exotic hardwood of your choice that has a groove milled or routed in it with a Moto-tool, rotary table, router, or whatever.

I've found that older scrap forklift skids can have some beautiful small pieces of recoverable oak in them. A good source for exotic and unusual woods is *Edelco*. My current choice is pecan, since I live in a pecan grove undergoing heavy pruning.

For projects which will rarely be assembled and disassembled, you can make use of "L" brackets and wood screws. Access these from an open bottom. For removable end plates, use some sort of threaded insert or glue a bracket in place.

Pop rivets are another very useful fastening method. But do note that these are semi-permanent. You'll

## new from DON LANCASTER

### ACTIVE FILTER COOKBOOK

The sixteenth (!) printing of Don's bible on analog op-amp lowpass, bandpass, and highpass active filters. De-mystified instant designs. \$24.50

### CMOS AND TTL COOKBOOKS

Millions of copies in print worldwide. THE two books for digital integrated circuit fundamentals. About as hands-on as you can get. \$24.50 each.

### INCREDIBLE SECRET MONEY MACHINE II

Updated 2nd edition of Don's classic on setting up your own technical or craft venture. \$18.50

### LANCASTER CLASSICS LIBRARY

Don's best early stuff at a bargain price. Includes the CMOS Cookbook, The TTL Cookbook, Active Filter Cookbook, Micro Cookbooks I & II, newly revised Incredible Secret Money Machine II, and those Hardware Hacker II reprints. \$119.50

### LOTS OF OTHER GOODIES

Ask the Guru I or II or III .....	\$24.50
Hardware Hacker II or III .....	\$24.50
Book-on-Demand Resource Kit .....	\$39.50
PostScript Beginner Stuff .....	\$39.50
Intro to PostScript Video .....	\$39.50
GENie PSRT Sampler .....	\$29.50
PostScript Reference II .....	\$28.50
PostScript Tutorial/Cookbook .....	\$18.50
Whole works (all PostScript) .....	\$350.00
PostScript Secrets Brochure .....	FREE
Hacking Secrets Brochure .....	FREE

### POSTSCRIPT SECRETS

A Book/Disk combination crammed full of free fonts, insider resources, utilities, publications, workarounds, fontgrabbing, more. For most any PostScript printer. Mac or PC format. \$39.50

### BLATANT OPPORTUNIST I

The reprints from all Don's Midnight Engineering columns. Includes the case against patents, book on demand publishing, toner secrets, paradigm stalking, insider research, lots more. \$24.50

### RESOURCE BIN I

A complete collection of all Don's Nuts & Volts columns to date, including a new index and his master names and numbers list. \$16.50

### FREE SAMPLES

Well, nearly free anyway. Almost. Do join us on GENie PSRT to sample all of the Guru's goodies. The downloading cost on a typical Guru file is 21 cents. Call (800) 638-9636 for connect info.

FREE VOICE HELPLINE VISA/MC

**SYNERGETICS**  
Box 809-NV  
Thatcher, AZ 85552  
(602) 428-4073

Write in 146 on Reader Service Card.



## RESOURCE BIN NAMES & NUMBERS

<b>Advance Process Supply</b> 400 N Noble Street Chicago, IL 60622 (312) 829-1400	<b>Dimco-Gray</b> 8200 S Suburban Road Centerville, OH 45458 (513) 433-7600	<b>Hammond Manufacturing</b> 1690 Walden Avenue Buffalo, NY 14225 (716) 894-5710	<b>Micro Plastics</b> Hwy 178 North Flippin, AR 72634 (501) 453-2261	<b>Serpac</b> 612 Commercial Avenue Covina, CA 91723 (818) 331-0517
<b>Appliance &amp; ANPD</b> 1110 Jorie Blvd CS9019 Oak Brook, IL 60522 (708) 990-3484	<b>DynaArt Designs</b> 3535 Stillmeadow Lane Lancaster, CA 93536 (805) 943-4746	<b>Industrial Product Bulletin</b> 301 Gibraltar Drive Morris Plains, NJ 07950 (201) 292-5100	<b>Model Railroader</b> 21027 Crossroads Circle Waukesha, WI 53187 (414) 796-8776	<b>Silicon Chip</b> 500-B Bi-County Blvd Farmingdale, NY 11735 (516) 293-3000
<b>Appliance Manufacturer</b> 29100 Aurora Road #200 Solon, OH 44139 (216) 349-3060	<b>Dynamark &amp; Color Key</b> 3M Center Bldgs 220 & 223 Saint Paul, MN 55144 (800) 328-1186	<b>ITW/Fastex</b> 195 Algonquin Road Des Plaines, IL 60016 (312) 299-2222	<b>New Equipment Digest</b> 1100 Superior Avenue Cleveland, OH 44114 (216) 696-7000	<b>Small Parts</b> 500-B Bi-County Blvd Miami Lakes, FL 33014 (305) 557-8222
<b>Bead Manufacturing</b> 110 Mountain Grove Bridgeport, CT 06605 (203) 334-4124	<b>EAI</b> 540 Frontage Road Northfield, IL 60093 (312) 446-6660	<b>Kepro</b> 630 Axminister Drive Fenton, MO 63026 (800) 325-3878	<b>PacTec</b> Enterprise & Executive Aves Philadelphia, PA 19153 (215) 365-8400	<b>Southern Sign Supply</b> 127 Roesler Road Glen Burnie, MD 21061 (301) 768-8600
<b>Dick Blick</b> Box 1267 Galesburg, IL 61401 (800) 447-8192	<b>Edelco</b> PO Box 5373 Asheville, NC 28813 (704) 255-8765	<b>Keystone Electronics</b> 31-07 20th Road Astoria, NY 11105 (718) 956-8900	<b>Paper Direct</b> 57 Romanelli Avenue S Hackensack, NJ 07606 (800) A-PAPERS	<b>Stimpson</b> 900 Sylvan Avenue Bayport, NY 11705 (516) 472-2000
<b>Bopla Enclosure Systems</b> 7330 Executive Way Frederick, MD 21701 (301) 696-9300	<b>FomeBords</b> 2211 N Elston Avenue Chicago, IL 60614 (800) 362-6267	<b>Lindsay Publications</b> PO Box 538 Bradley, IL 60915 (815) 935-5353	<b>Paper Plus</b> 300 Oceangate #800 Long Beach, CA 90802 (213) 436-8291	<b>Synergetics</b> Box 809 Thatcher AZ 85552 (602) 428-4073
<b>Bud Industries</b> 7733 West Olive Avenue Peoria, AZ 85345 (602) 979-0300	<b>Fotofoil</b> 4400 N Temple City Blvd El Monte, CA 91734 (818) 444-4555	<b>LMB Heeger</b> 2946 E 11th Street Los Angeles, CA 90023 (213) 261-0382	<b>Pelican Products</b> 2255 Jefferson Street Torrance, CA 90501 (213) 328-9910	<b>Vector</b> 12460 Gladstone Ave. Sylmar, CA 91342 (818) 365-9661
<b>Delvies Plastics</b> 133 West Haven Avenue Salt Lake City, UT 84165 (800) 533-5843	<b>GEnie PSRT</b> 401 N Washington St Rockville MD 20850 (800) 638-9636	<b>Machine Design</b> 1100 Superior Avenue Cleveland, OH 44144 (216) 696-7000	<b>Roper Whitney</b> 2833 Huffman Blvd Rockford, IL 61103 (815) 962-3001	<b>Vero</b> 1000 Sherman Avenue Hamden, CT 06514 (203) 288-8001
<b>Design News</b> 44 Cook Street Ste 210 Denver, CO 80206 (303) 388-4511	<b>BF Goodrich</b> 9921 Brecksville Road Brecksville, OH 44141 (216) 447-5000	<b>MetalPhoto</b> 18531 S Miles Road Cleveland, OH 44128 (216) 475-0555	<b>Satco</b> 924 S 19th Avenue Minneapolis, MN 55404 (800) 328-4644	<b>Zero Manufacturing</b> 777 Front Street Burbank, CA 91502 (818) 846-4191

have to drill them out if you ever need any access. Which might be just what you want. For a plug in dimmer or other "live" power line project.

A variation on pop rivets can give you "instant threads" in thin metals or even in wood. Squeezing an insert will cause a portion of it to collapse, locking a threaded cylinder into your panel. Early sources included *Rivnuts* from *B.F. Goodrich*, but I'm not sure these are still available. Their fancy "industrial grade" tools cost much more than a pop rivet gun. Any larger hardware store should have pop-rivet compatible thread systems.

### Panels and artwork

It is now ultra trivial to get first rate and fully professional artwork for all of your dials and panels. The secret is the incredibly stupendous PostScript computer language. We have seen details on this back in *Resource Bin #9*, also available in my Resource Bin reprints and as file #511 NUTS9.PS on my *GEnie PSRT*.

I've got bunches more for you on PostScript. Just write or call for your free *PostScript Insider's Secrets* mailer.

And my *Synergetics* stocks everything you'll need to become a PostScript pro. Hundreds of PSRT library files are also downloadable. This is by far your fastest and lowest cost method to get started in PostScript.

The simplest and cheapest way to get great looking prototype panel art is to use raw PostScript to print onto the self-stick mylar sheets offered by *Paper Plus* or *Paper Direct*.

You then take a *second* and *clear* or *see-thru colored* self-stick mylar sheet and apply it *over* the first sheet, thus locking the toner inside a two layer mylar sandwich. Then you just stick these onto your panel.

If you are extremely careful, you can also use your final artwork as a drilling and punching guide.

A new and extremely promising hacker prototype imaging system is known as the *Toner Transfer System* offered by *DynaArt Designs*. We've seen in past columns how useful this product is for any direct toner printed circuit prototypes. Where you directly transfer your toner from PostScript to the circuit board for direct etching.

The *DynaArt* material can also be

used in its *decal* mode. The material is basically a stable transfer sheet onto which a thin high temperature but water soluble glue has been applied. You can try the same thing yourself by using a premium white glue from the art store and a windshield wiper for an applicator. But the *DynaArt* stuff is low in cost and ready to use.

At any rate, you laser print your PostScript artwork to the *DynaArt* material. Their decal method differs slightly from their printed circuit transfer method. To use their decal method, you'll first print. You next overspray your choice of a removable lacquer or a permanent urethane clear coating over the toner images and beyond their edges. When dry, you cut the individual images somewhat oversize and soak them in water. The backing coat dissolves and the toner can be slid onto the panel. Just like a traditional model railroad decal.

Pressure and heat can be applied to help fuse the toner to your panel. You can optionally remove the lacquer with a suitable solvent, giving you a "silk screen" effect.

Speaking of which, silk screens

have been the traditional method of doing panels for limited and small volume production. Because of the front end expense and time cutting a screen, these work best for a dozen or more identical panels. Three good sources for silk screen materials and supplies include *Dick Blick*, *Advance Process*, and *Southern Sign Supply*.

And, of course, your leading source for all printed circuit materials and supplies is *Kepra*.

While you'll still find traditional electronic decals offered by some old-line sources, these simply aren't worth the time and effort. These are basically a sucker bet guaranteed to give second-rate results that range from unprofessional to atrocious.

For totally superb panel artwork, consider linking PostScript to those old anodized aluminum dialplate systems offered by *MetalPhoto* or *Fotofoil*. These are somewhat pricey but are ideal for rugged and durable one-up or small quantity panels. They are also useful for museum signs and electronic relay rack panels. Picture an aluminum sheet which has only partially gone through the anodizing process, leaving a brightly colored but a very open and spongy surface. A photo emulsion is then applied. You later expose the emulsion through your custom PostScript artwork. A contact printer or an enlarger can be used. Followed up by a traditional darkroom slopping-in-the-slush.

After developing, you can boil the panel in a magic glop that reseals the surface, closing a sapphire (literally!) hard surface and locking your image *inside* the panel. The results are quite durable. It takes a highly dedicated vandal to harm a Metalphoto panel.

While the lettering and images are normally black, a wide range of bright colors are offered. Also the "plain old gray" of traditional anodizing. You might use a *reverse* technique to give you a black panel having colored or gray lettering. Again, this is utterly trivial with PostScript.

There is also a slightly cheaper self-stick vinyl based system. This one used to be called *ScotchCal*, but has been renamed *Dynamark*. Picture a white self-stick vinyl with a colored photoglop on it. You contact print the vinyl using strong sunlight or some other u-v source, again through your PostScript artwork.

Where present, the light hardens the photoglop against chemical attack. You then use a Webril wipe or other

nonwoven pad to apply a chemical that removes the color from all areas which were not photohardened. The result is white over a color or vice versa, depending on whether you've used normal or reverse artwork.

A clear epoxy overcoat gives you reasonable scratch resistance. You can then peel and stick your vinyl over your aluminum or other panel. Once again, if you are *very* careful, the vinyl can also be used as a punching and drilling guide.

Kits are readily available, both in single and assorted colors. Very thin aluminum versions are also offered.

There is also a non-stick product called *Scotch Color Key* offered to the printing industry. This gives you a mylar film having color selectively photoapplied to it. Many dozens of colors are offered. There are lots of prototyping opportunities here.

### Injection molds?

The rule here is simple. *Don't even think of it!* These are *certain* to end up a net loss of time, energy, and money in any small scale setup. No matter that you can walk into the hobby shop and pick up a two dollar kit with a dozen precision molded parts in it. The economics simply do not apply to you. Your costs are ridiculous.

Yes, there are low end injection molding machines. But they produce small, weak, and cheap looking parts. The *Quick Shooter* is one of these that uses a stock drill press for cylinder pressure. A much better machine in the two kilobuck range is offered by *Delvies Plastics*. Who also offer a wide variety of sanely priced plastics, tools, and books.

Two more reasonable alternatives to cast parts are to use extrusions or to do vacuum forming. One good source of vacuum forming books is *Lindsay Publications*. Who also stock a wide variety of machine shop texts, both old and new.

### Finding prototyping components

As with any technical field, your foremost resource to tune yourself into who makes what are the trade journals. Many of these are free on professional request. We've seen lots more on trade journals way on back in *Resource Bin #8* and *#495 NUTS8.PS*.

Start off with *Machine Design* and *Design News*. Then go to the two big free throwaways that are chock full of prototyping stuff: *Industrial Product Bulletin* and the *New Equipment Digest*.

The latter often has great free product samples on bingo request.

Three little known sources of useful prototyping materials, supplies and ideas do include *Appliance*, *Appliance Manufacturer*, and the *Appliance New Product Digest*.

The school shop magazines are also very handy. These include *School Shop* and *Industrial Education*, among a dozen others. A source of vocational ed shop supplies is *Satco*.

Do not overlook the good old *Model Railroader* magazine on your favorite newsstand. They are particularly big on smaller wood, plastic, and metal parts. Along with tools hard to find elsewhere. Not to mention the finest technical writing of any publication. Anywhere, ever.

There are also a bunch of home machinist and live steam mags, but I think we'll save them for a possible future column.

### This month's contest

For this month's contests, just tell me about your favorite little-known prototyping resource or technique. The more obscure and unusual, the better. Or just tell me the address for the *Quick Shooter* folks. Uh, it seems I misplaced it at deadline time.

Actually our new pup may have eaten it. Last week she ate a one dollar bill. Her tastes are improving though; she did a ten in yesterday.

No, she is not a Nauga. At least not yet, anyway.

There will be some newly revised *Incredible Secret Money Machine II* books going to the dozen or so best (or earliest) entries, along with an all-expense-paid *tinaja quest* (FOB Thatcher, AZ) for two going to the very best of all.

Let's hear from you. ♦

---

*Microcomputer pioneer and guru Don Lancaster is the author of 28 books and countless articles. Don maintains his no-charge tech helpline found at (602) 428-4073, besides offering all of his own books, reprints, and all of his consulting services. He also has a free brochure full of his resource secrets waiting for you. Your best calling times are 8-5 on weekdays, Mountain Standard Time.*

*Don is now the sysop of GENIE PSRT, where a special Resource Bin topic has been reserved for Nuts & Volts readers. You can contact GENIE at (800) 638-9636 (voice) for connect info. Or you can reach Don at Synergetics, Box 809, Thatcher, AZ 85552.*

# \$99 Flutterwumpers

I sure do receive bunches of helpline calls asking for an automated XY table that costs \$99 or less. Since this is so simple and easy to do, I'm amazed that no *Midnight Engineer* has yet picked up on all the utterly incredible opportunities here.

I'll define a *flutterwumper* as any eminently hackable entity that moves and then either chomps or spits. A few horribly restrictive examples include...

- Printed circuit drills
- Animation stands
- Santa Claus machines
- CAD/CAM mills
- Paint detailing robots
- Pick-and-place positioners
- Programmable sign routers
- Waterknife cloth shaping
- Embroidery customizers
- Automated weaving looms
- Vinyl lettering cutters
- Jewelry lost wax formers
- Silk screen master makers
- Precision laser shapers
- Award engraving systems
- Cake or pizza decorators
- Spark discharge EDM

But the concept of *intrinsic flutterwumplicity* clearly transcends all of these. If, instead, you go back to the basics and attack the *generic* system fundamentals using the latest of new concepts, tools, and products, then all sorts of \$99 flutterwumper solutions become painfully obvious. Opportunities that are going begging.

Let's look at some secret insider first principles of low cost flutterwumping...

## Don't Sweat the Mechanics

The mechanical part of any flutterwumper is the *least* of your worries. Instead, you should tightly focus on a generic *system* of software, firmware, hardware, and drivers that can form the *absolute minimum* interface and control core for most *any* flutterwumper.

One that is workable with *any* choice of mechanical goodies. Of any size.

In what follows, we'll assume a 2-1/2 D flutterwumper where you want full independent motion along apparent X and Y axes, but only a simple "up-down" or "on-off" action along your Z axis.

## No Gantries Need Apply

The classic XYZ gantry is just about the *worst* possible way to build a flutterwumper. *Avoid gantries at all costs!* For X has to support both Y and Z. And Y in turn has to support Z. Just like a multi-stage rocket, you need tons of machine to support ounces of payload. And your position inaccuracies are *certain* to pile up. So are your costs.

One early "semi-gantry" workaround was known as the *H system*. This worked sorta like those old parallel rule mechanism drafting tables. Two steppers sit stationary at the bottom of the H, both driving a convoluted belt. The *differential* stepper motions set X and Y positions.

If the steppers both twist in the *same* direction, you get X motion. If the steppers twist in *opposite* directions, you get Y axis motion. See the July 11, 1994 *Machine Design* for the latest reincarnation of this ancient ploy.

*Divide and Conquer* is a useful anti-gantry technique. Move the chomper in the X direction with one system. And move the work in the Y direction using a second system. Nicely converting a complex 2-1/2 D problem into a pair of vastly simpler 1 D and 1-1/2 D ones.

But your best way around a gantry is to *forget about Cartesian co-ordinates entirely!* Any old brain dead micro can instantly convert between reference systems. True XYZ is often a totally unneeded waste. As long as you have at least three degrees of freedom, you can fake XYZ.

For instance, two pivoting linear steppers that share a common shaft slider can hit any X-Y point.

Many robots use a cylindrical co-ordinate system. Made from a rotating base and a doubly hinged arm. Nothing slides. One stepper twists for base orientation. A second twists for arm elevation; a third for upper hinge angle.

Even more elegant is a revolutionary new *virtual ways* system. Described in the August 15, 1994 issue of *Design News*. Take a base plate and place six ballscrews or linear steppers uniformly around a large circle on it. Now lean each ballscrew by 45 degrees or so and attach them all to a smaller upper head plate. The head plate can easily assume all of the normal lathe or mill motions. But *there are no precision sliding contacts anywhere!* All bearings are plain old round ones. All forces are pure tension or compression with *zero* side loadings.

## Minimize Chomper Load

The less you've got to shove around, the cheaper and simpler your flutterwumper. The two usual loads on your chomper head are *side loading* and *chomper mass*.



Side loading comes about from reactions against the work being machined. Two heavy side loading examples include rotary mills and wood routers. Especially if your tools are not kept ultra sharp. Tool speeds and feed rates also get into the act. Printed circuit drills and waterknives have considerably less side loading. Zero or near-zero side loading can result with laser cutters or inkjet heads.

If possible, try and use a flutterwumper chomper having minimum side loading. Then carefully select your tool choices, sharpness, and feed rates for further reductions. Any super-cheap solution can run real slow, saved by that good old "Uh, compared to what?" factor.

The heavier your chomper, the worse the problems when you try to shove it around. See if you can't find creative alternatives to *move only what really needs moved*.

For instance, instead of shoving an entire router motor around, can you support the motor high up and use a rotary shaft instead? Better yet, can you go pneumatic and use a tiny air motor and a very flexible supply hose or two? Can you make it self-advance on some sort of a Bendix? The *OralSafe* dental supply offers a \$13 *disposable handpiece*. This gem is easily cut down to form a tiny air turbine the size and mass of a plotter pen.

On a laser cutter, mount the laser solidly on the *side* of the flutterwumper frame and then use mirrors to deliver the beam energy to the chomper head. For minimum mirror problems, use large and defocused delivery beams.

Regardless of your flutterwumper goals, spend lots of time and thought minimizing your chomper head mass and side loadings. Ask yourself what the absolute minimum work action is needed.

And then deliver it. As baggage-free as you can.

### Car Alternator Steppers?

There's two choices in flutterwumper motion controls: *open loop* or *closed loop*. When in open loop, you tell the flutterwumper where to go and hope it gets there. Often using digital *stepping* motors that move in discrete chunks. Positioning errors may pile up due to backlash, calibration accuracy, or tool wear. In closed loop, you continuously measure where you are, derive an error signal and then you force motions closer to your desired position. Often using analog *servo* motors that seek out a low error.

Closed loop is usually more expensive and complex. It also can be gross overkill. If you do go closed loop, note that *PCIM* is a good magazine here, that *Hewlett Packard* makes position encoders, and that a new technology called *binary chain codes* has big advantages over those Gray encoders. See [HACK80.PDF](#) for details.

Except for its ludicrous cost, the *Hurst SLS* is a dandy linear stepper. Twenty pounds of force in four mil steps.

Useful hacker sources for steppers and such include *American Science & Surplus*, *C&H Sales*, *Herbach and Rademan*, *Fair Radio Sales*, *Burden's Surplus Center* or *AST Servo Systems*. But big steppers are kinda pricey.

Can car alternators be used as power steppers? The amazing answer is that they can. They are ultra cheap and deliver an amazing amount of kick. The secrets involve accessing the "wye" center tap; rewinding the ampere turn maximized coils so they span a single pole; and using a three-phase drive setup.

Full details appear in a superb *John Rees* video.

## FLUTTERWUMPER RESOURCES

**Adobe PostScript**  
PO Box 7900  
Mountain View, CA 94039  
(800) 833-6687

**Hewlett Packard**  
PO Box 10301  
Palo Alto, CA 94303  
(415) 857-1501

**Allegro-Sprague**  
Box 15036  
Worcester, MA 01605  
(508) 853-5000

**Hurst Manufacturing**  
Box 326  
Princeton, IN 47670  
(812) 385-2564

**American Sci & Surp**  
601 Linden Place  
Evanston, IL 60202  
(708) 475-8440

**Machine Design**  
1100 Superior Avenue  
Cleveland, OH 44144  
(216) 696-7000

**AST Servo Systems**  
115 Main Road Box 97  
Montville, NJ 07045  
(201) 335-1007

**Microchip Technology**  
2355 W Chandler Blvd  
Chandler, AZ 85224  
(602) 938-7373

**Burden's Surplus Center**  
PO Box 82209  
Lincoln, NE 68501  
(800) 488-3407

**Motorola**  
5005 E McDowell Road  
Phoenix, AZ 85008  
(800) 521-6274

**C&H Sales**  
PO Box 5356  
Pasadena, CA 91107  
(800) 325-9465

**MSC Specialties**  
6700 Discovery Blvd  
Mableton, GA 30059  
(800) 645-7270

**Design News**  
275 Washington Street  
Newton, MA 02158  
(617) 964-3030

**OralSafe**  
43529 Ridge Park Drive  
Temecula, CA 92590  
(800) 237-8825

**Scott Edwards**  
964 Cactus Wren Lane  
Sierra Vista, AZ 85635  
(602) 459-4802

**Parallax**  
3805 Atherton Road #102  
Rocklin, CA 95765  
(916) 624-8333

**Fair Radio Sales**  
PO Box 1105  
Lima, OH 45802  
(419) 227-6573

**PCIM**  
2472 Eastman Avenue #33-34  
Ventura, CA 93003  
(804) 658-0933

**GEnie**  
401 N Washington Street  
Rockville, MD 20850  
(800) 638-9636

**John Rees**  
Rt 1 Box 1551  
Sautee, GA 30571  
(706) 865-5495

**Gerber Scientific**  
83 Gerber Road  
S Windsor, CT 06074  
(203) 644-1551

**SGS**  
1000 E Bell Road  
Phoenix, AZ 85022  
(602) 867-6259

**Grainger**  
2738 Fulton Street  
Chicago, IL 60612  
(312) 638-0536

**Small Parts**  
PO Box 4650  
Miami Lakes, FL 33014  
(305) 557-8222

**Herbach & Rademan**  
401 E Erie Avenue  
Philadelphia, PA 19134  
(215) 426-1700

**Texas Instruments**  
PO Box 809066  
Dallas, TX 75380  
(800) 336-5236

### Use Modern Drivers

The days of on-off control of a stepper winding by a big ole Darlington power transistor are long gone. Still, it should cost you no more than \$5 per axis maximum for your power driver interface.

For maximum speed and the most tail twisting, you'll need a *current* drive or a *pulse modulated* drive. With provisions for lower holding currents that minimize heat losses between actual motions.

These days, a full dedicated microcomputer makes more sense than a stepper driver chip. Among other reasons, the dedicated micro is cheaper and easier to debug.

While *Allegro-Sprague*, *Motorola*, and *SGS* remain popular sources of stepper chips and power drivers, the

new *Power+Arrays* series from *Texas Instruments* are ultra simple and cheap. In particular, do check out their three channel TIPC2301 for car alternator drives.

### Pick a Two-brainer

The secret insider trick for flutterwumper intelligence is to split your problem in half. *Use only the simplest and scungiest brain-dead dedicated micro for only those unique custom tasks that are absolutely essential.* Do everything else using a stock computer or a PostScript printer.

On the brain-dead end, those PIC series micros from *Microchip Technology* make the most sense. Because these totally blow away anything from Intel or Motorola. They cost as little as two bucks each. Fine low cost development support is also offered. Especially that *Basic Stamp* from *Parallax*, and the *PIC Design Tools* from *Scott Edwards*. Scott also offers a \$25 *stamp extender* that can easily be reprogrammed to do your *entire* flutterwumper.

You have your smart and big generic computer talk to your little and dedicated one by using some sort of meta language. While either HPGL or *Gerber* standards could be used, these may conflict with your \$99 cost goal.

Instead, I feel that an ultra simple meta language using the absolute minimum of single character ASCII codes makes the most sense. Say N, E, S, W, U, D, and H for instance. Sent over a higher speed stock RS232 serial channel. Later on, after your costs are under control, you can add such features as vector motions, repeats, speedup, back-channel feedback, and comments.

Let the big computer do the co-ordinate transformations. Let the little one use raw native motions.

Regardless of your choice of a meta language, *make positively certain it is open and fully documented.* And is freely available to anyone at *zero* cost.

What about your smart computer? The big one that does all the work. For that, we'll send...

### PostScript to the Rescue

The general purpose *PostScript* computer language offers compellingly strong advantages for flutterwumpers. PostScript easily handles graceful curves, fancy fonts, tool path compensation, and microsizing. Exotic co-ordinate transforms are trivial. The majority of the most powerful graphic design tools in the world use PostScript. Others are easily convertible.

Besides, PostScript can be available *free*. And is simple and fun to use.

There are three possible routes here. By a *crossporting* technique, you can simply use a laser printer as a general purpose PostScript computer, writing your meta language commands out a suitable port. Your flutterwumper then becomes a laser printer peripheral.

Or, you use a PostScript laser printer to write a meta language file *back* to your host for recording. From there, you'll stash the file in a disk library or resend it at your convenience. Using ordinary serial comm.

Finally, there is a shareware version of PostScript called *GhostScript* that can run on most any host. GhostScript is available for the downloading from PSRT and many other on-line sources. Be sure to get 3.0 or higher. Since the full sourcecode is *included* with GhostScript, you can easily customize it any way you like.

Here's one approach to a...

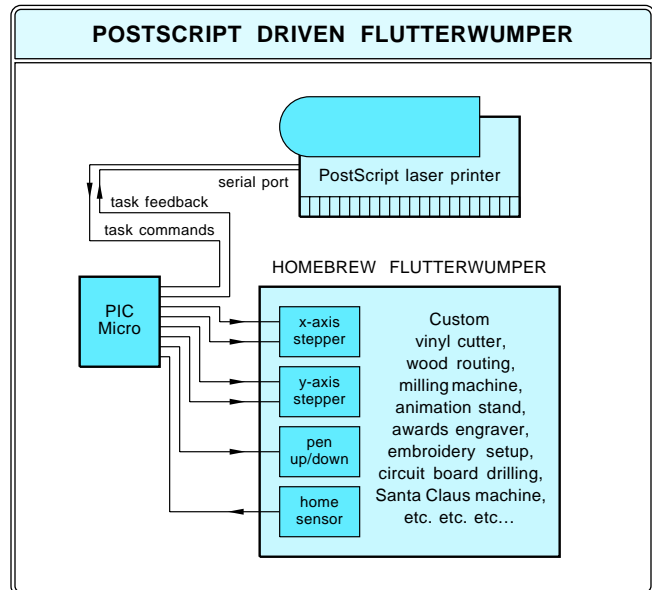

Any reasonable line art you can draw on paper can be sent to your flutterwumper. You first persistently download a special header to your PostScript printer, and then accept routine and *unmodified* artwork. The header intercepts the usual *showpage* and other commands and works some magic instead.

Being a general purpose computer language, PostScript easily outputs to your meta language, transforming on the fly. PostScript generates *paths*. Either directly or through use of the *pathforall* operator. The paths can be converted to vector steps with the *flattenpath* operator. From here, a few lines of code will convert to your meta language in the desired flutterwumper resolution.

Full details in [POSTVECT.PS](#) and [FLUTUTIL.PS](#).

### For More Help

Our resource sidebar gathers up several names and numbers needed for serious flutterwumper work. Besides those I've already mentioned, *Small Parts* is a great source for bits and pieces, while useful bigger lumps are offered by *Grainger* and *MSC Specialties*.

Additional support can be found on the *Flutterwumper Library* shelf of my [www.tinaja.com](#) web site. And in my *Blatant Opportunist* reprints.

Consulting services are also available on the concepts shown. Let's hear from you. ♦

*Microcomputer pioneer and guru Don Lancaster is the author of 33 books and countless articles. Don maintains a US technical helpline you'll find at (520) 428-4073, besides offering all his own books, reprints and various services.*

*Time and funding constraints limit this service to US callers only.*

*Don has a free new catalog crammed full of his latest insider secrets waiting for you. Your best calling times are 8-5 weekdays, Mountain Standard Time.*

*Don is also the webmaster of [www.tinaja.com](#) where a special area has been set aside for Midnight Engineering readers. You can also reach Don at *Synergetics*, Box 809, Thatcher, AZ 85552. Or email [don@tinaja.com](mailto:don@tinaja.com)*



Don Lancaster's

# RESOURCE BIN

number sixteen

## Opportunities in hacker robotics.

**O**ur usual reminder here that the *Resource Bin* is now a two-way column. You can get tech help, consultant referrals and off-the-wall networking on nearly any electronic, *tinaja questing*, personal publishing, money machine, or computer topic by calling me at (602) 428-4073 weekdays 8-5 MST. I've got a free pair of insider secret resources brochures waiting for you when you call or write.

A portion of my PSRT RoundTable on *GENie* has also been set aside for you *Nuts & Volts* readers. This is the place to go for instant tech answers. Among the many files in our library, you will find complete reprints and preprints for all of my *Resource Bin* columns. I've just added a new "fast access" feature for you. Have your modem dial (800) 638-8369, followed by HHH. Then `XTX99005,SCRIPT`.

A free *GENie* brochure if you voice call (800) 638-9636.

Some more magazine comings and goings: *Science Probe* has apparently ceased publication. I'd guess a lack of appropriate advertisers was the main reason. *Wired* is a brand new mag published out of Multimedia Gulch. Their first issue had articles in it on cellular phone hacking and virtual reality, among others. Not a "real" technical magazine, but one certainly worth a look.

I am deeply saddened by a local college completely dropping their full electronics program. This faced the realities of a monumental lack of any real student interest (caused mostly by local high schools whose technical offerings are best described as an outright atrocity); and by the total absence of instant and high paying aerospace jobs. But it sure seems short sighted to me.

Like eating your seed corn.

Yeah, there's only a dozen hi-tech employers in the entire Gila Valley. And only two of those are beyond the

hand-to-mouth stage. But *not one* of them can find the quality of technical help they need. Or the motivation.

Enough already. Our 35Z5 contest was the most popular one ever. After awarding 35 of the promised 12 new *Incredible Secret Money Machine* books, I shut this one down. My apologies to the many hundreds of you who have entered too late to win.

For those of you that didn't know the answer, here's two hints: (A) The 35Z5 is located right beside the 50L6, and (B) Trace out that wire on pin 3 and see where it goes.

### Robotics hacking

I do get a lot of helpline calls over robotics topics. But the bottom line is that there is very little overall interest in hobby robotics these days. There is virtually *no way* to make any profit offering hobby robotics projects, kits, products, or services.

At least not today.

One reason is that the "trashcan" and "android" role model images of robots are just about totally useless. An outright joke for sure. One of the favorite stunts in any intro robotics course is to have the students design a robot to clean up their dinner plates.

**NEXT MONTH: Don takes a look at the ham radio scene.**

Only one student in a dozen picks up on the fact that *Sears* has been selling these for decades.

When and if we pick up effective speech recognition, useful fuzzy logic algorithms, autonomous nav, and some non-klutzy "end effectors", then maybe the trashcans and the androids may get better. But only after their computing and reasoning ability gets at least up to the pussy cat level.

Till then, the hobby robotic scene seems an unmitigated disaster. Yes, there are low end toys and high end industrial robotic systems. As with any product anywhere, a new robotic project must do some task cheaper, better, and far more conveniently than older "non-robotic" solutions.

Or your dog flat out won't hunt.

Another problem is that robotics is best done as a team effort. The skills needed include a precision machinist, a kinematics specialist, an electronic supertech, a nav-literate EE, and a few software specialists well qualified in machine language, C++, AI, and fuzzy logic. Plus someone who knows how to sell something. It is rare that a one person show can put the needed act together by themselves.

And, right now, there flat out isn't near enough underlying cash flow to attract that quality of hired help.

While there is no "hobby robotics" industry as such, there sure are lots of potential resources out there. I'm left with the feeling we have a technical field with a fringe but no center.

### Robotic suppliers

The leading hobby robotics supply house in the world is *Small Parts*. The folks here stock everything that your hardware store never heard of. They also custom cut metal and plastic sheet, rod, and tubing. Their catalog is a must. Yes, they do welcome small orders. From anybody.

Surplus stores are a rather obvious source of robotic parts and ideas. The foremost surplus store in the world, of course, is *American Science & Surplus* who used to be *JerryCo*.

The highest profile outfit is *Edmund Scientific*. Their catalog is also a must. For motors and similar heavy iron, try *C & H Sales*, *Burden's Surplus Center*, or *Northern Hydraulics*.

Plus good old *Fair Radio Sales* for military electronics and raw iron.

The "big three" of precision parts are *PIC Design*, *Stock Drive Products*, and *Winfred M. Berg*. If you have to ask how much all their products cost, you cannot afford them.

For reasonable robotic gears, try *Plastock/Plastimatic*. For rubber sheets and tubing, *Hygenic Manufacturing*. For pins, axles, and such, try *Robert A. Main*. A most unusual supplier.

The traditional industry superstores are another obvious robotics resource. Be sure to check *Grainger* for motors and pumps. And *McMaster-Carr* for just about everything industrial.

There are a lot of specialty houses that are in some other business, but just happen to have lots of neat stuff useful for robotics hacking. Several obvious examples include the *Player Piano Company*, *Aircraft Spruce and Specialty*, *Outwater Plastics*, *US Plastic*, and *Satco*. The latter is a technical education supply house.

*Heathkit* did have their *Hero* series of robots before they went out of the hobby kit business. Some robotics and training material does remain in their industrial education division, which is apparently still active.

Finally, don't forget the hobby and toy stores. Some toys have all sorts of robotic possibilities. Not the least of which is Radio Shack's *Armatron* and all the great imported pneumatic kits from Fischertech. Start off with those *America's Hobby Center* catalogs.

### Magazines and trade journals

There are a dozen or so robotics magazines. The *SRS Encoder* is a new labor-of-love newsletter, published by the *Seattle Robotics Society*, a leading amateur robotics group. There is also a *Robotics Experimenter* magazine. The rest are industry trade journals or scholarly publications. I've tried to list most of them in our *Names & Numbers* sidebar.

I was unable to review all of these by column deadline time, so do let me know which ones you find useful.

*Electronics Now* runs an occasional robotic project or tutorial.

Many trade journals focus on some other field, but may happen to have great robotics info in them. The two best mechanical trade journals are *Machine Design* and *Design News*. The largest industrial supply throwaway mags are *New Equipment Digest* and *Industrial Product Bulletin*.

*Appliance*, the *Appliance New Product Digest*, and the *Appliance Manufacturer* trade journals sometimes have motor

info and other ads for materials with robotics potential. As do pubs from the SAE library, formerly the *Society of Automotive Engineers*.

For lots of sensor and transducer info, check into *Sensors* magazine, and *Measurement & Control*. For the motion control info, your best trade journals include *PCIM*, *Motion*, *Motion Control*, and *MotorTechniques*.

There are a number of vocational education magazines that may get into robotic topics. Typical examples include both *School Shop* and *Industrial Education*. There are a dozen more.

And don't forget *Model Railroader*. Their ads do offer a great selection of unusual tools and materials. These folks have been in the robotic business for years. They just do not seem to want to admit it.

### Robotic opportunities

OK, so what can be done in hobby robotics today? With the possibility of a reasonable cash return for your time and effort? I see several areas where original thought might come up with several long term robotic solutions....

**low pressure pneumatics**- We saw back in *Resource Bin #7* and in my *Resource Bin Reprints* available from *Synergetics* how you could buy a low pressure 3-way air valve for only a quarter each. Low pressure air has yet to take off but it's got outstanding robotics potential. Aquarium pumps can be used as compressors, and your actuators can be nothing but a balloon, bellows, or some rolling diaphragm. You can get much more force much more linearly than you could ever hope to with a solenoid or another electronic solution.

**autonomous nav**- The key to any robot is knowing where it is at and which way it is facing. What is ultimately needed is a \$5 *Navicube* that once and for all solves nav problems. Several approaches to the navicube include fluxgates, accelerometers, gyros, IR sensors, or GPS receivers. The time is long overdue for lots of creative new solutions to "Where am I?" and "How did I get here?" problems.

**linear steppers**- Another underrated product is the *linear stepping motor*. Which is just a regular stepper motor with an added nutplate on its front. Connected to an Acme threaded but non-rotating shaft. As the nutplate steps, the shaft moves in and out with surprising force. The *Hurst* model *SLS*

## new from DON LANCASTER

### ACTIVE FILTER COOKBOOK

The sixteenth (!) printing of Don's bible on analog op-amp lowpass, bandpass, and highpass active filters. De-mystified instant designs. \$24.50

### CMOS AND TTL COOKBOOKS

Millions of copies in print worldwide. THE two books for digital integrated circuit fundamentals. About as hands-on as you can get. \$24.50 each.

### INCREDIBLE SECRET MONEY MACHINE II

Updated 2nd edition of Don's classic on setting up your own technical or craft venture. \$18.50

### LANCASTER CLASSICS LIBRARY

Don's best early stuff at a bargain price. Includes the CMOS Cookbook, The TTL Cookbook, Active Filter Cookbook, Micro Cookbooks I & II, newly revised Incredible Secret Money Machine II, and those Hardware Hacker II reprints. \$119.50

### LOTS OF OTHER GOODIES

Ask the Guru I or II or III .....	\$24.50
Hardware Hacker II or III .....	\$24.50
Book-on-Demand Resource Kit .....	\$39.50
PostScript Beginner Stuff .....	\$39.50
Intro to PostScript Video .....	\$39.50
GEnie PSRT Sampler .....	\$29.50
PostScript Reference II .....	\$28.50
PostScript Tutorial/Cookbook .....	\$18.50
Whole works (all PostScript) .....	\$350.00
PostScript Secrets Brochure .....	FREE
Hacking Secrets Brochure .....	FREE

### POSTSCRIPT SECRETS

A Book/Disk combination crammed full of free fonts, insider resources, utilities, publications, workarounds, fontgrabbing, more. For most any PostScript printer. Mac or PC format. \$39.50

### BLATANT OPPORTUNIST I

The reprints from all Don's Midnight Engineering columns. Includes the case against patents, book on demand publishing, toner secrets, paradigm stalking, insider research, lots more. \$24.50

### RESOURCE BIN I

A complete collection of all Don's Nuts & Volts columns to date, including a new index and his master names and numbers list. \$16.50

### FREE SAMPLES

Well, nearly free anyway. Almost. Do join us on GEnie PSRT to sample all of the Guru's goodies. The downloading cost on a typical Guru file is 21 cents. Modem access: (800) 638-8369, then a HHH. On prompt, XTX99005,SCRIPT.

FREE VOICE HELPLINE VISA/MC

**SYNERGETICS**  
Box 809-NV  
Thatcher, AZ 85552  
(602) 428-4073

Write in 146 on Reader Service Card.

## RESOURCE BIN NAMES & NUMBERS

<b>Aircraft Spruce &amp; Special</b> P.O. Box 424 Fullerton, CA 92632 (800) 824-1930	<b>Electronics Now</b> 500-B Bi-County Blvd. Farmingdale, NY 11735 (516) 293-3000	<b>Measurement &amp; Control</b> 2994 W. Liberty Avenue Pittsburgh, PA 15216 (412) 343-9666	<b>Player Piano Company</b> 704 East Douglas Wichita, KS 67202 (316) 263-3241	<b>Robotics World</b> 6255 Barfield Road Atlanta, GA 30328 (404) 256-9800
<b>American Sci &amp; Surp</b> 601 Linden Place Evanston, IL 60202 (708) 475-8440	<b>Fair Radio Sales</b> 1016 E. Eureka Street Lima, OH 45802 (419) 227-6573	<b>Model Railroder</b> 1027 N. Seventh Street Milwaukee, WI 53233 (414) 272-2060	<b>Robomatrix Reporter</b> 121 Chanion Road New Providence, NJ 07974 (908) 771-7714	<b>SAE</b> 400 Commonwealth Dr Warrendale, PA 15096 (412) 776-4970
<b>Appliance &amp; ANPD</b> 1110 Jorie Blvd CS9019 Oak Brook, IL 60522 (708) 990-3484	<b>GENie</b> 401 N. Washington Street Rockville, MD 20850 (800) 638-9636	<b>Motion</b> Box 6430 Orange, CA 92613 (714) 974-0200	<b>Robot Experimenter</b> Box 458 Peterborough, NH 03458 (603) 924-3843	<b>Satco</b> 924 S 19th Avenue Minneapolis, MN 55404 (800) 328-4644
<b>Appliance Manufacturer</b> 29100 Aurora Road #200 Solon, OH 44139 (216) 349-3060	<b>Grainger</b> 5959 W. Howard Street Chicago, IL 60648 (312) 647-8900	<b>Motion Control</b> 800 Roosevelt Dr E408 Glen Ellyn, IL 60137 (708) 469-3373	<b>Robot Times</b> 900 Victors Way, Box 374 Ann Arbor, MI 48106 (313) 994-6088	<b>Sensors</b> 714 Concord Street Peterborough, NH 03458 (603) 924-9631
<b>Automation</b> 600 Sumner Street Stamford, CT 06904 (216) 696-7000	<b>Heath Company</b> PO Box 217 Benton Harbor, MI 49022 (616) 982-3200	<b>Motor Techniques</b> 120 S Chapparral Ct #200 Anaheim, CA 92808 (714) 283-1123	<b>Robotica</b> 32 E. 57th Street New York, NY 10022 (212) 924-3900	<b>Small Parts</b> Box 381966 Miami, FL 33238 (305) 751-0856
<b>Winfred M. Berg</b> 511 Ocean Avenue East Rockaway, NY 11518 (516) 599-5010	<b>Hygenic Manufacturing</b> 1245 Home Avenue Akron, OH 44310 (216) 633-8460	<b>New Equipment Digest</b> 1100 Superior Avenue Cleveland, OH 44114 (216) 696-7000	<b>Robotics</b> 655 Americas Avenue New York, NY 10010 (212) 989-5800	<b>SRS Encoder</b> Box 30668 Seattle, WA 98103 (206) 362-5267 [E-mail]
<b>Burden's Surplus Center</b> PO Box 82209 Lincoln, NE 68501 (800) 488-3407	<b>Industrial Prod Bulletin</b> 301 Gibraltar Drive Morris Plains, NJ 07950 (201) 292-5100	<b>Outwater Plastics</b> 4 Passaic Street Wood-Ridge, NJ 07075 (800) 526-725-7112	<b>Robotics &amp; Mfg</b> Maxwell Hs, Fairview Pk Elmsford, NY 10523 (914) 592-7700	<b>Stock Drive Products</b> 2101 Jerico Turnpike Hyde Park, NY 11040 (516) 328-0200
<b>C &amp; H Sales</b> 2716 E. Colorado Blvd. Pasadena, CA 91107 (213) 681-4925	<b>Robert A. Main</b> 555 Goffle Road Wyckoff, NJ 07481 (201) 447-3700	<b>PCIM</b> 2472 Eastman Avenue Venture, CA 93003 (805) 658-0933	<b>Robotics Newsletter</b> 1730 Massachusetts NW Washington, DC 20036 (212) 371-0101	<b>Synergetics</b> Box 809 Thatcher AZ 85552 (602) 428-4073
<b>Design News</b> 221 Columbus Avenue Boston, MA 02116 (617) 536-7780	<b>McMaster-Carr</b> Box 54960 Los Angeles, CA 90054 (213) 945-2811	<b>PIC Design</b> Benson Road Middlebury, CT 06762 (203) 758-8272	<b>Robotics Database</b> Box 617024 Orlando, FL 32861 (407) 295-1094	<b>US Plastics</b> 1390 Neubrecht Road Lima, OH 45801 (800) 537-9724
<b>Edmund Scientific</b> 101 E. Gloucester Pike Barrington, NJ 08007 (609) 573-6250	<b>Machine Design</b> Penton Plaza Cleveland, OH 44144 (216) 696-7000	<b>Plastock/Plastimatic</b> Three Oaks Road Fairfield, NJ 07006 (201) 575-0038	<b>Robotics Today</b> One SME Drive, Box 930 Dearborn, MI 48128 (313) 271-1500	<b>Wired</b> 544 Second Street San Francisco, CA 94107 (415) 904-0664

is typical. But these even appear on some auto carburetors as engine idle controllers.

**the visual mouse**– Some lower cost method to cause certain actions to happen just by *looking* at something. Obvious aps include menu selections, handicapped aides, virtual reality, "if looks could kill" video games. Maybe a pair of glasses with a laser diode and an attitude detector.

**printed circuit drills**– The single most important new breakthrough robotics project anytime ever would be a \$250 device that automates the drilling of small printed circuit boards. Perhaps two linear steppers, one to move the board and one to position the drill. Maybe a dentist's air turbine drill to keep the mass down. Once this new breakthrough project exists, larger models could lead you to animation stands, low priced vinyl sign cutters, computer embroidery machines, the whole nine yards.

**car alternator steppers**– "Real" stepper motors in the high power sizes are horrendously expensive and hard to drive. But these are what you need for CAD/CAM milling, for Santa Claus machines, automated woodcarving routers, and similar projects. It should be possible instead to take a \$5 car alternator and convert it into a three phase stepping motor or even into a switched reluctance servo motor. I've seen some videos of hobbyists who have successfully done just this. But nobody has done the fundamental engineering here to see what is and is not possible.

### This month's contest

Again, I do have the hollow feeling that I have missed some really major hobby robotics resources. So, for this month's contests, just tell me about any resource that is potentially useful for hobby robotics. If possible, send me a catalog or sample copy and get me on their mailing list as well. There

will be some newly revised *Incredible Secret Money Machine II* books going to the dozen or so best entries, along with an all-expense-paid *tinaja quest* (FOB Thatcher, AZ) for two going to the very best of all.

Let's hear from you. ♦

*Microcomputer pioneer and guru Don Lancaster is the author of 28 books and countless articles. Don maintains his no-charge tech helpline found at (602) 428-4073, besides offering all of his own books, reprints, and all of his consulting services. He also has a free brochure full of his resource secrets waiting for you. Your best calling times are 8-5 on weekdays, Mountain Standard Time.*

*Don is now the sysop of GENie PSRT, where a special Resource Bin topic has been reserved for Nuts & Volts readers. For fast modem access, dial (800) 638-8369 and enter HHH. When prompted, enter XTX99005,SCRIPT. You can reach Don at Synergetics, Box 809, Thatcher, AZ 85552.*



Don Lancaster's

# RESOURCE BIN

number thirty-seven

## A look at sensors and sensing.

**O**ur usual reminder here that the *Resource Bin* is now a two-way column. You can get tech help, consultant referrals and off-the-wall networking on nearly any electronic, *tinaja questing*, personal publishing, money machine, or computer topic by calling me at (602) 428-4073 weekdays 8-5 Mountain Standard Time.

A portion of my PSRT RoundTable on *GENIE* has also been set aside for you *Nuts & Volts* readers. This is the place you go for instant tech answers. Among the many files in our library, you will find complete reprints for all the *Resource Bin* columns.

I did manage to wrangle one super special signup deal for you *Resource Bin* readers. Ten free hours and new Internet access features. See the trailer blurb for details.

### Sensors and Sensing

This month, I thought we'd take a look at sensors and sensing. A *sensor* is any device that converts some other physical attribute into an electrical or electronic signal. Sensors of one sort or another are involved in just about any electronic project.

And they sure are one hot topic on our helpline and on PSRT.

Usually, there will be two stages involved in any sensor problem. First, you'll have to do your actual sensing. This gets done using a *transducer* of some type. The result is often a very small signal, possibly a few tens of millivolts. Noise is *always* a problem in any sensing situation. And *extreme* caution is required to take care of this very weak signal.

Next, you will typically have to do some *signal conditioning* to convert the sensed signal into something useful. Such as a higher current, a pulse train, or a digital word.

Signal conditioning tricks include shielding, differential mode sensing, isolation, offsetting, amplifying, temp

comp, filtering, and A/D conversion. For really small signals, synchronous detection, correlation, integration, or averaging can also be applied.

Four sources of conditioning chips are *Analog Devices*, *Crystal*, *Signetics*, and *Linear Technology*.

Unusual newer sensor technologies and ideas often appear in courses and publications from *SPIE*.

### Sensor Trade Journals

As I may have mentioned a time or two before, those free trade journals are *the* best way to get informed in a big hurry on almost any subject. Start with *Ulrich's Periodicals Dictionary* on your library's reference shelf.

This gem lists some 150,000 trade journals and other magazines.

At any rate, your horse's mouth trade journal is *Sensors*. From Carl Helmers of early *Byte* magazine fame.

Also try *Measurement & Control*.

You can also go to industry specific mags for all sorts of useful stuff. Say *Pollution Equipment News* for typical environmental sensors, *Powder & Bulk*

**NEXT MONTH: Don looks at high frequency techniques and hackable resources.**

*Solids* for level controls, or *American Laboratory* for chemical sensors. Or even *Weight Engineering* for coverage on strain gauges.

### One Stop Shopping

Your highest profile source for just about any sensor is *Omega*. These folks offer scads of impressive free catalogs on temperature, level, flow, pH, strain, pressure, data acquisition, and bunches more. Pricey, though.

One shirtsleeves source for nearly any industrial sensing instrument or tool is *Abbeon Cal*.

### Temperature

The traditional way of accurately measuring temperatures is to use a *thermocouple*. This is simply a pair of connected but *dissimilar* metals. The millivolt-size output voltage ends up related to absolute temperature.

You do have to provide a *cold side compensator*, which usually will offset to ambient room temperature or zero degrees. And you have to be careful not to allow other dissimilar contacts anywhere in your sensing loop.

Thermocouples are identified by letter. In order of increasing temp, as types T, J, E, and K. Type J is made of iron and constantan.

The free *Temperature Handbook* from *Omega* is the thermocouple bible.

Thermocouples are often best for the high temperature measurement of kilns or whatever. But the usual rule is to avoid them when you can.

Your standard hacker temperature sensor is the ordinary silicon diode. These change by *minus* two millivolts per degree C. Usable to 150 C.

The 272-0123 from *Radio Shack* is a low cost digital thermometer using a diode sensor. Other low cost sources advertise in, of all places, *Food Service Product News*.

Which is also a great diet mag. Just read it before each meal.

And then guess whether that blue glop in the big bottle is a new dessert topping or a grease trap clarifier.

The semiconductor folks have long ago discovered that any pair of silicon diode junctions operating at different currents gives a linear output that is proportional to absolute temperature. The earliest example of this was the *National LM224*. Also carded at *Radio Shack*. Output current changes by one percent for every 3 degrees C.

A handfull of really exciting new chips have recently been announced. *Dallas* has a DS1620 combined digital thermometer and thermostat. *Analog*



Devices sells a TMP01 programmable controller. Range of both devices is -55 to +125 C. One obvious use is as a hot tub controller.

### Pressure

Silicon pressure sensors are rapidly becoming low cost commodities.

These are basically a "drumhead" etched into bulk silicon. Strain sensors are implanted on the drumhead. As the pressure changes, the drumhead flexes, causing a resistance change.

There are two main pressure sensor types. The *absolute* sensor compares pressure against a perfect vacuum. A *differential* sensor instead compares a pressure difference that's *between* two ports. If one of those ports is left open to your ambient air, then you have a variant called a *gauge* sensor.

Temperature compensation and a lot of amplification are often needed when sensing pressure. Some sensors are offered both as raw chips or with signal conditioning and temperature compensation built in.

Your two most obvious sources for the pressure sensors are *Motorola* and *Microswitch*. But the real action comes down from *Sensym*, *I.C. Sensors*, and *Novasensor*.

Sensym has a *Solid State Pressure Sensors* handbook. This one includes a great slide chart.

An oddball use for pressure sensors is in low pressure tire alarm systems. *Fleet Specialties* is one source.

There's also some purely resistive approaches to pressure sensing. One source is *Interlink Electronics*. With mice and music apps.

For ultra cheap, you can sometimes get by using nothing but the black anti-static foam that chips arrive in. But repeatability and reliability can be big problems here.

At the high end, *Force Imaging* sells subminiature and quite thin sensors that work from 1 to 20,000 PSI.

A modification to a pressure sensor will let it measure acceleration. The motion of a mass is sensed. The rate of change of motion of the mass is the mass velocity. The rate of change of the velocity is the acceleration. Except for airbag sensors, these devices are still very expensive.

One source is *Silicon Designs*.

### People Detectors

A person emits a very distinctive spectrum in the far infrared. The old way of dealing with this was with a *pyrolytic detector*. Any and all sanely

priced people detectors have a unique problem. They are basically capacitors and only respond to *changes*.

One older workaround was to chop up your signal using a fan blade or a vibrating reed. A better and newer method is to use a special *Fresnel* lens that has "hot" and "cold" optical areas. As the person crosses the beam, the signal strength changes.

A newer and cheaper approach to people sensing is the *kynar piezo film* from *AMP Piezo*. This is just a plastic sheet that is sensitive to both flexure and infrared inputs. Free samples are literally stapled to their data sheets. Besides people detectors, this product builds shock sensors, heat detectors, and really great microphones.

Because the Fresnel lens design is tricky, you are better off starting with a commercial \$12 occupancy detector and kitbashing it. A California law mandates these in all new building construction, so they are a commodity part. Electrical supply wholesalers are your usual source. *Leviton* is a major manufacturer.

### Light

There are a wide variety of light sensors out there. The *photoconductive* sensors made from cadmium sulfide vary their resistance over a wide (but highly nonlinear) range with temp.

Again carded at *Radio Shack*.

Ancient *photomultiplier tubes* still remain the sensor of choice for ultra sensitive astronomy and similar uses. *Hamamatsu* is the leader here.

*Solar cells* will generate a current proportional to input irradiance. For self powered calculators, or remote site power generation. Lots of these in *Home Power* magazine.

Three variations on solar cells are *phototransistors*, *photodarlington*s, and *phototriacs*. These amplify to produce a much stronger signal. But they do need external supply power. These get used for everything from dusk to dawn sensors, door openers, power isolation, and shaft encoders.

Lots of ads for these right here in *Nuts & Volts*. *Burr-Brown* is one source for low cost, large area detectors with built-in conditioning. The MOC3020 is a typical *Motorola* phototriac.

But *Texas Instruments* has just run away with all the marbles. They have an exciting new line of low cost and hassle-free *light-to-frequency converters*. Their first device is the programmable TSL230. They've also got a TSL235 in a lower cost vertical package. Under a

## new from DON LANCASTER

### ACTIVE FILTER COOKBOOK

The sixteenth (!) printing of Don's bible on analog op-amp lowpass, bandpass, and highpass active filters. De-mystified instant designs. **\$24.50**

### CMOS AND TTL COOKBOOKS

Millions of copies in print worldwide. THE two books for digital integrated circuit fundamentals. About as hands-on as you can get. **\$24.50** each.

### INCREDIBLE SECRET MONEY MACHINE II

Updated 2nd edition of Don's classic on setting up your own technical or craft venture. **\$18.50**

### LANCASTER CLASSICS LIBRARY

Don's best early stuff at a bargain price. Includes the CMOS Cookbook, The TTL Cookbook, Active Filter Cookbook, PostScript video, Case Against Patents, Incredible Secret Money Machine II, and Hardware Hacker II reprints. **\$119.50**

### LOTS OF OTHER GOODIES

Ask the Guru I or II or III	\$24.50
Hardware Hacker II, III or IV	\$24.50
Micro Cookbook I	\$19.50
PostScript Beginner Stuff	\$29.50
PostScript Show and Tell	\$29.50
Intro to PostScript Video	\$29.50
PostScript Reference II	\$32.50
PostScript Tutorial/Cookbook	\$19.50
PostScript by Example	\$32.50
Understanding PS Programming	\$29.50
PostScript: A Visual Approach	\$22.50
PostScript Program Design	\$24.50
Thinking in PostScript	\$22.50
LaserWriter Reference	\$19.50
Type 1 Font Format	\$15.50
Acrobat Reference	\$24.50
Whole works (all PostScript)	\$380.00
PostScript Insider Secrets	FREE
Hacking Insider Secrets	FREE

### POSTSCRIPT SECRETS

A Book/Disk combination crammed full of free fonts, insider resources, utilities, publications, workarounds, fontgrabbing, more. For most any PostScript printer. Mac or PC format. **\$29.50**

### BOOK-ON-DEMAND PUB KIT

Ongoing details on Book-on-demand publishing, a new method of producing books only when and as ordered. Reprints, sources, samples. **\$39.50**

### THE CASE AGAINST PATENTS

For most individuals, patents are virtually certain to result in a net loss of sanity, energy, time, and money. This two volume set shows you tested and proven real-world alternatives. **28.50**

### BLATANT OPPORTUNIST I

The reprints from all Don's Midnight Engineering columns. Includes a broad range of real world, proven coverage on small scale technical startup ventures. Stuff you can use right now. **\$24.50**

### RESOURCE BIN I

A complete collection of all Don's Nuts & Volts columns to date, including a new index and his master names and numbers list. **\$24.50**

### FREE SAMPLES

Well, nearly free anyway. Almost. Do join us on GENIE PSRT to sample all of the Guru's goodies. The downloading cost on a typical Guru file is **21 cents**. Modem access: Dial (800) 638-8369. On prompt, JOINGENIE, then DMD524 on key.

FREE VOICE HELPLINE VISA/MC

**SYNERGETICS**  
Box 809-NV  
Thatcher, AZ 85552  
(602) 428-4073

Write in 146 on Reader Service Card.

## SENSORS AND SENSING RESOURCES

<b>Abbeon-Cal</b> 123-208A Gray Ave Santa Barbara CA 93101 (805) 966-0810	<b>Corning Electronics</b> 35 Riverside Drive Corning NY 14830 (607) 962-0555	<b>General Eastern</b> 20 Commerce Way Woburn MA 01801 (800) 225-3208	<b>Klockit</b> PO Box 636 Lake Geneva WI 53147 (800) 556-2548	<b>Nova Sensor</b> 1055 Mission Ct Fremont CA 94539 (510) 490-9100	<b>SenSym</b> 1804 McCarthy Blvd Milpitas CA 94035 (408) 954-1100
<b>Allegro Micro Systems</b> Box 15036 Worcester MA 01605 (508) 853-5000	<b>Crystal Semiconductor</b> PO Box 17847 Austin TX 78744 (800) 888-5016	<b>GENie</b> 401 N Washington St Rockville MD 20850 (800) 638-9636	<b>Leviton</b> 59-25 Little Neck Pkwy Little Neck NY 11362 (800) 824-3005	<b>Omega Engineering</b> One Omega Dr Stamford CT 06907 (800) 826-6342	<b>Signetics/J/Philips</b> PO Box 3409 Sunnyvale CA 94088 (408) 991-2000
<b>American Laboratory</b> 30 Controls Drive Shelton CT 06484 (203) 926-9300	<b>Dallas Semiconductor</b> 4401 Beltwood Pkwy S Dallas TX 75244 (214) 450-0400	<b>Hamamatsu</b> 360 Foothill Rd Bridgewater NJ 08807 (201) 231-0960	<b>Linear Technology</b> 1630 McCarthy Blvd Milpitas CA 95035 (408) 432-1900	<b>Panametrics</b> 221 Crescent Waltham MA 02254 (617) 899-2719	<b>Silicon Designs</b> 1445 NW Mall Street Issaquah WA 98027 (206)391-8329
<b>Amp Kynar Piezo</b> Box 799 Valley Forge PA 19482 (610) 666-3500	<b>Dinsmore Instrument</b> 1814 Remell St Flint MI 48503 (313) 744-1330	<b>Home Power</b> PO Box 520 Ashland OR 97520 (916) 475-3179	<b>Magnetic Research</b> 122 Bellevue Avenue Butler NJ 07405 (201) 838-6348	<b>pHoenix Electrode</b> 6103 Glenmont Houston TX 77081 (713) 772-6666	<b>SPIE</b> PO Box 10 Bellingham WA 98227 (206) 676-3290
<b>Analog Devices</b> PO Box 9106 Norwood MA 02062 (617) 329-4700	<b>Figaro Engineering</b> 1000 Skokie Blvd #575 Wilmette IL 60091 (708) 256-3546	<b>HyCal</b> 9650 Telstar Ave El Monte CA 91731 (800) 932-2702	<b>Measurement &amp; Control</b> 2994 W Liberty Ave Pittsburgh PA 15216 (412) 343-9666	<b>Pollution Equip News</b> 8650 Babcock Blvd Pittsburgh PA 15237 (412) 364-5366	<b>Synergetics</b> Box 809 Thatcher AZ 85552 (602) 428-4073
<b>Analytical Chemistry</b> 1155 16th St NW Washington DC 20036 (202) 872-4570	<b>Fisher Scientific</b> 711 Forbes Ave Pittsburgh PA 15219 (412) 562-8300	<b>IC Sensors</b> 1701 McCarthy Blvd Milpitas CA 95035 (408) 432-1800	<b>Micro Switch</b> 11 W Spring St Freeport IL 61032 (815) 235-6600	<b>Powder/Bulk Solids</b> PO Box 640 Morris Plains NJ 07950 (201) 292-5100	<b>Texas Instruments</b> PO Box 809066 Dallas TX 75380 (800) 336-5236
<b>F W Bell</b> 6120 Hanging Moss Rd Orlando FL 32807 (407) 678-6900	<b>Fleet Specialties</b> PO Box 4575 Thous Oaks CA 91359 (818) 889-1716	<b>Institute of Navigation</b> 1800 Diagonal Rd #480 Alexandria VA 22314 (703) 683-7101	<b>Motorola</b> 5005 E McDowell Rd Phoenix AZ 85008 (800) 521-6274	<b>Precision Navigation</b> 1235 Pear Avenue #111 Mountain View CA 94043 (415) 962-8777	<b>Ulrichs Dictionary</b> 121 Chanlon Rd New Prov NJ 07974 (908) 771-7714
<b>Burr-Brown</b> 6730 S Tucson Blvd Tucson AZ 85706 (602) 746-1111	<b>Force Imaging</b> 3424 Touhy Avenue Chicago IL 60645 (800) 348-3240	<b>Interlink Electronics</b> PO Box 40760 Santa Barbara CA 93103 (805) 684-2100	<b>National Semicon</b> 2900 Semiconductor Rd Santa Clara CA 95052 (800) 272-9959	<b>RF Design</b> 6300 S Syracuse #650 Englewood CO 80111 (303) 220-0600	<b>Walker Scientific</b> Rockdale St Worcester MA 01606 (800) 962-4638
<b>Cole-Parmer</b> 7425 N Oak Park Ave Niles IL 60714 (800) 323-4340	<b>Food Service Prd News</b> 104 Fifth Avenue New York, NY, 10011 (212) 206-7440	<b>Iotron</b> 3857 Birch Street #521 Nwprt Beach CA 92660 (714) 551-5477	<b>Navtech Books</b> 2775 S Quincy St #610 Arlington VA 22206 (800) NAV-0885	<b>Sensors</b> 174 Concord Street Peterborough NH 03458 (602) 924-9631	<b>Weight Engineering</b> PO Box 1043 Alton IL 62002 (618) 377-9096

buck and a half in quantity.

For starters, pick up their *TSL230 Applications Brief*. More use details in NUTS33.PS and HACK80.PS posted to my *GENie* PSRT.

### pH

A *pH sensor* measures the acidity or alkalinity of a chemical solution. The most likely use you'd have for one is for swimming pool maintenance. Or maybe for water quality checks. The sensor probes are a chemical cell the shape of a small test tube.

Ion conductivity through a porous membrane generates a voltage that is proportional to pH.

These *demand* dc amplifiers having a super high input impedance. Temp comp and tracking is a must.

Calibration is also important. Many older systems do this by using stock *buffer solutions* for adjustment.

A circuit and more details on a pH meter in my *CMOS Cookbook*.

Sources for pH probes are *Omega*, *Fisher*, *Corning*, *Markson*, *Cole-Parmer*, *Iotron*, and *pHoenix Electrode*.

Current theoretical info shows up in *Analytical Chemistry*.

There's a brand new pH measuring scheme called the *field sensitive FET*. I'm still trying to chase this one down.

Please let me know if you can find me any more details on these. A free *Incredible Secret Money Machine II* for your trouble.

### It's a Gas

Gas sensors can be used for alcohol breath analyzers, in carbon monoxide alarms, and fuel vapor detectors.

These are magic compounds heated by a platinum wire. The resistance is a function of the concentration of your target gas. These are usually *not* very selective, so other activating gases can cause problems.

Your leading source here is *Figaro*. More details and working circuits in my *Hardware Hacker* reprints.

### Magnetic Fields

The stock solutions to sensing fairly strong magnetic fields are devices using the *Hall Effect*. Which is just a

current related to field strength.

Two main sources here are *Allegro/Sprague*, who offer a great *Hall Effect Optoelectronic Sensors* data book. And *MicroSwitch* who has their older but highly useful *Hall Effect Transducers* applications manual.

Linear Hall Effect parts output a voltage which is proportional to the magnetic field. Digital parts output a logic level or pulse train.

Nearly all Hall devices are woefully insensitive. They only work properly with *strong* magnetic fields such as a *nearby* magnet. One that is *very* close. One quarter inch is really pushing it. Still, these are the low cost device of choice for position and speed sensors. Also for use with proximity sensors and flowmeters.

Two main sources of premium Hall magnetic sensors and instruments are *F.W. Bell* and *Walker Scientific*.

But note that Hall devices are *totally* unsuitable for compass sensing of the earth's magnetic field. They miss by two to three *orders* of magnitude.

One compromise solution builds a

compass with a rotating magnet and then decides that magnet's position. Low cost *Dinsmore Instruments* parts do just this. But their accuracy is often limited to 22.5 degrees or so.

Mechanical motion is involved.

Instead, *the* device to use for high quality compasses is the *fluxgate*. This is simply a small magnetic core. One winding switches the core into and out of saturation. When *not* saturated, the core "gathers in" nearby lines of the earth's field.

When saturated, the core "releases" the lines. A pair of X and Y windings senses this gathering and releasing, producing output pulses that end up proportional to the local strength of the earth's field.

One source of hacker fluxgates is *Magnetic Research*. A quality source of fluxgate compasses is *KVH*. Others do advertise in *GPS World*.

The *Institute of Navigation* is another extremely useful resource here. As is the *Navtech Bookstore*.

A fluxgate alternative is offered by *Precision Navigation*.

A construction project on fluxgates appeared in the January, 1994 issue of *R.F. Design* on pages 24-32. And full construction info on a unique low cost fluxgate compass project appears in my *Hardware Hacker III* reprints.

## Humidity

The *humidity* is the amount of water vapor in the air. Which might be the *absolute* quantity of water present. Or else the *relative* amount of moisture compared against your max possible without fog or rain. Humidity is a very strong function of temperature, so you nearly always have to measure the temperature as well.

Zero cost humidity sensors include horsehair, an unwashed blond human hair, or a nylon fishline. They all get longer and shorter in response to the humidity. Surplus fishline humidity controllers are available from several *Nuts & Volts* advertisers.

The most accurate way to measure humidity is with a *chilled mirror*. A mirror on a thermoelectric cooler gets adjusted to the *dew point*, the temp where condensation first occurs. Light either does or does not get scattered to servo the temperature to the dew point. A simple (but highly nonlinear) calculation finds the humidity.

A variation on dewpoint is the *sling psychrometer* or those related *wet bulb* and *dry bulb* systems.

Sadly, there is no really cheap and

universal solid state humidity sensor. Those that do work operate only over a limited humidity range. And they tend to be outrageously expensive in small quantities.

Several of the better sensors are capacitors whose dielectric constant changes with humidity. These can be micropower and directly generate a frequency in a simple RC oscillator. Sources include *General Eastern* and *Panametrics*. Related moisture sensors are offered by *HyCal*.

Since surface adsorption is often involved, most humidity sensors are easily contaminated. Certain sensors can get flushed or otherwise cleaned; but others can not.

There's also older resistive sensors. But not used much, though.

One very low cost source of analog hygrometers is *Klockit*. *Abbeon Cal* sells better grade instruments.

## This Month's Contest

As our contest for this month, just tell me about any unusual or little known sensor resource. Or tell me about some new off-the-wall sensor use or application.

There will be a largish pile of my new *Incredible Secret Money Machine II* books going to the dozen or so better entries, plus an all-expense-paid (FOB Thatcher, AZ) *tinaja quest* for two that will go to the very best of all.

I have just picked up some more Apple II+ and IIe computers, cheap enough to put to use as dedicated controllers. And even including a few rare and collectible Apple III's as well. Lots of cards, drives, monitors, and parts, too. Call for info.

Let's hear from you. ♦

---

*Microcomputer pioneer and guru Don Lancaster is the author of 32 books and countless tech articles. Don maintains his no-charge tech helpline found at (602) 428-4073, besides offering all of his own books, reprints, and all of his consulting services. He also has a free catalog full of his resource secrets waiting for you. Your best calling times are 8-5 on weekdays, Mountain Standard Time.*

*Don is now the sysop of GENIE PSRT, where a special Resource Bin topic has been reserved for Nuts & Volts readers. For modem access: (800) 638-8369. When prompted, enter JOINGENIE. When asked for a keyword, enter DMD524.*

*You can also reach Don at Synergetics, Box 809, Thatcher, AZ 85552. Or send any messages to his Internet address of SYNERGETICS@GENIE.GEIS.COM.*

# Elegant Simplicity

One of the goals I have consistently sought out over the years is to develop designs and products which inherently possess an *elegant simplicity*. Like many truly great concepts, elegant simplicity can be hard to pin down. But you sure know it when you've got it.

One clue is when industry insiders end up shaking their heads in stunned disbelief.

Elegant simplicity combines the best of Schumacher's "do more with less" and Buckminster Fuller's "appropriate technology". Yeah, *Whole Earth Catalog* stuff. It goes way on back to that ancient *Ockham's Razor* principle of the most fundamentally direct explanation often ending up the most correct. Or Einstein's "Always seek out the simplest possible solution – *but none simpler*".

Probably the best way we can get a handle on elegant simplicity is to look at several products and designs that clearly have it. Here are my selections for a few of the all time winners...

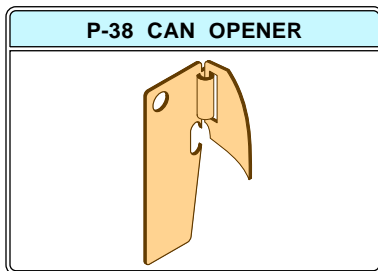

I consider the P-38 can opener to be by far the finest invention of the twentieth century. Bar none. Compared to the P-38, such utter frivolities as radio, television, autos, or aviation are not even in the same league. Yes, even *Hostess Twinkies* pale by comparison.

For sheer bang for the buck and inherent ergonomics, nothing can remotely compare. The P-38 opens cans. Any classic tin can, any time, any place. It runs forever. No batteries required. Fully portable. Self-protecting. Cost is zilch. No user manuals or tutorials.

Let's see what we got here. Two tiny pieces of stamped steel. One is grooved for extra strength. The blade folds flat for storage or pops open for use. The first time you see one, you will swear that it couldn't possibly work. But it sure does. The secret is "walking" around the folded rim present on all classic cans. Your thumb and forefinger form a double lever that pivots on that rim. With a surprising amount of force magnification. Probably many *tons* of pressure per square inch at the blade edge.

The elegant simplicity here is profound: ultra low cost

and very small size. Perfectly matched to both the user and the job to be done. Use of the absolute minimum of force concentration to reliably carry out one well defined task. While a throwaway item intended for one time use, these last forever. A classic in every sense of the word.

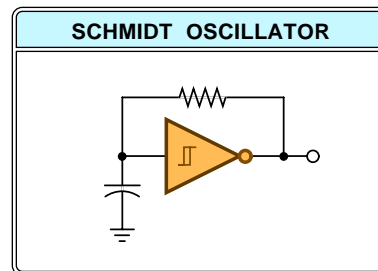

What is the simplest possible electronic oscillator you can build? For square waves, the *Schmidt Oscillator* wins hands down. It uses 2-1/6 parts, always self starts, is fairly temperature and voltage stable, and outputs more or less symmetric square waves. This dude can be micropower at low frequencies and drives fairly heavy loads.

The key is to pick any CMOS gate or inverter that has *Schmidt Trigger* inputs having *hysteresis*. One-sixth of a 74HC14 is a good four cent starting point. If a *rising* input voltage goes past an *upper trip point*, the output goes *low*. If a *falling* input voltage goes below the *lower trip point*, the output goes *high*.

On power up, the capacitor cannot instantly charge, so the input will stay low, and the output will flip high. This starts charging the cap, slowly raising your input voltage. When the input voltage reaches your upper trip point, the output flips low. Now, the resistor starts discharging the capacitor towards ground. When it hits the lower trip point, the process repeats.

The choice of resistor and capacitor value determines the time constant and thus your oscillation frequency. Start off with a 220K resistor and a 0.001 microfarad capacitor for something in the mid audio range. Variable resistors or switched capacitors can be added to extend the range.

All of which gives us a nearly pure implementation of integrating a square wave to get a triangular wave and then comparing the limits of the triangular wave to produce an inverted square wave.

Self-starting is inherent. The very first cycle on power up will be longer than the others. Which can be handy for such things as auto-repeat functions on a keyboard.

More details on Schmidt oscillators can be found in my *CMOS Cookbook*.

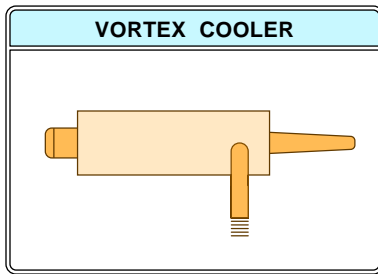

This one is nothing but a Tee shaped pipe. Blow air in the middle arm, and hot air comes out one end and cold air out the other. To -40 degrees and tons of refrigeration.

With zero moving parts.

Important uses are electronic cabinets, sewing machines, and general machine shop aps.

Shop air gets blown into the middle arm. This creates an internal hollow supersonic cyclone that travels at a speed of several hundred thousand RPM. The cyclone moves to the hot end, and a fraction of it exits.

Now for the tricky part: The remainder of the cyclone works its way back towards the cold end, *inside* the entry vortex. The velocity is still the same, but the radius is less. Thus, the *angular momentum* of the inner vortex has to be *lower* than the outside one. But since energy has to get conserved and since the angular momentum has obviously dropped, there has to be a net transfer of heat energy from the inner vortex to the outer one. The result is that the outer vortex heats, and the inner one cools. Finally, the highly cooled inner vortex exits via the cold air port.

An optional screw adjustment selects the cold fraction. Which lets you select your choice of maximum cooling or minimum temperature.

Two sources of vortex coolers are *Vortec* and *Exair*.

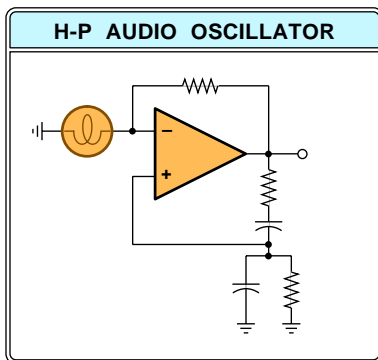

Would you believe that the entire *Hewlett-Packard* empire was based on one dimly lit pilot light?

The first H-P product was a low distortion, wide range *Wein Bridge* audio sinewave oscillator.

A *Wein Bridge* consists of a single pole RC high pass filter in series with a single pole RC lowpass filter. The gain of this network will be zero for very low or very high frequencies. The gain will be highest at a frequency where the time constants match. If the resistors are equal, the gain at the magic frequency will be 0.33 or one-third. Phase shift will also be zero at this frequency.

To make an oscillator out of this, you simply place an amplifier with a gain of 3.0 around the loop.

Whoa, not so fast. How do we get started? You have to provide a much higher gain for startup. And once you are

nicey oscillating, how do you keep your output amplitude constant and undistorted?

The key secret is to add some sort of stabilization to your amplifier. Raise the gain to start, and then carefully and continuously adjust the gain to hold your desired low distortion output. Such circuits are called AGC loops, short for *Automatic Gain Control*. As a further complication, you want your AGC loop to only respond to *long term changes* and not to those cyclic variations of each individual cycle. Otherwise, you just may increase, rather than decrease your distortion through intermodulation.

The traditional electronic solution here is to use a peak detector, integrator, and variable gain amplifier stage. A royal mess still today, but a real bear back in 1940.

Well, Mister Hewlett or Mister Packard (I forget which one) decided to use elegant simplicity instead. They noted that a pilot light is a *nonlinear resistance*. The resistance is low when cold and higher when hot. Which is why most light bulbs will burn out on power on. Further, there is a *thermal inertia* to a lamp that only allows its resistance to slowly change at the required subaudio rates.

By using a plain old pilot light as your AGC loop, you can eliminate any need for anything fancy.

On power up, the bulb is cold and you get lots of gain. During run time, the oscillator cycles at its normal safe low-distortion output value. If the gain goes up, the current through the bulb and its resistance also goes up, lowering the gain. In a tight self-stabilizing loop.

The rest, as they say, is history.

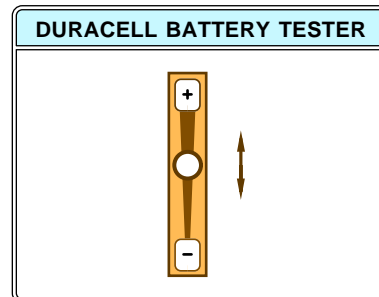

Battery testers can be a real hassle. First, you have to find a load resistor that is properly rated for the exact cell or cells you are measuring. You then actually measure the current or voltage under load and compare this against a set of design curves. Then you interpret the results.

The *Duracell* folks came up with a better way. They have literally *printed* their battery tester onto the blister package their cells come in. At stunningly low cost.

A marketing solution that is off scale when it comes to elegant simplicity. Any five year old can use it.

Here's how this gem works: A conductive pattern is first printed that forms a resistor. The resistor value is carefully matched to the cell being tested. The trapezoidal shape of the resistor is carefully selected so that the power density changes along its length. As a result, the top of the resistor gets hotter than the bottom. When connected to the test battery, a temperature gradient is formed, hot at the thin top and cooler at the thick bottom.

A temperature sensitive liquid layer has been printed on top of the test resistor. The *transition temperature* of the liquid crystal produces a bright green spot. The fresher the battery, the higher the spot moves up on the display.



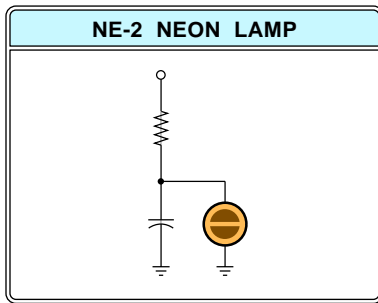

Back in its vacuum-tube heyday, the nine cent NE-2 neon lamp was by far the most versatile electronic part. Besides the classic flasher circuit I have shown here, the lowly neon lamp had an amazing variety of uses.

Stuff like a universal power tester, lightning protection, surge arresting, lamp dimming, electronic organ tone generation, bistable and astable flip flops, ultra cheap voltmeter replacements, twinkle lights, hot-chassis warning devices, polarity indicators, microammeters, radio tube filament checkers, long life pilot lights, pulse generation, electronic switch, threshold detector, ac-dc discriminator, touch switch, strobe light, synchronizer, radiation detector, ultraviolet sensor, threshold comparator, voltage regulator, turntable speed control, reference supply, dc coupler, or a sawtooth signal source. Plus bunches more.

Basically, you've got a small glass tube filled with low pressure neon gas, supporting two wire electrodes. While normally an open circuit, the neon ionizes when the supply voltage exceeded 90 volts. Once ionized, the lamp lights brightly and conducts heavily. When the supply voltage under the high current discharge drops below 55 volts, the lamp will extinguish and the cycle repeat. Only the positive terminal lights under DC. Both light under AC.

Sadly, the generally lower voltages of the solid state revolution sidelined the NE-2 into an undeserved early retirement. Yeah, they still cost less than a dime.

### What else?

Let's see. What else passes our elegant simplicity test? *Vise Grip* pliers fer sure. That old plastic nut starter from *Heathkit*. Or their integrated circuit extractor that can be approximated by a bent nail.

I kinda did like those *Conanda Effect* auto windshield washers that showed up a way back. Two fixed grooves in a simple fluidic nozzle that swept the washer glop all over the glass. Or Volkswagen's *Synchro* 4WD van that once and for all solved positraction problems by its optionally shoving a locking pin through the differential.

I'm also impressed by those new Analog direct storage EPROM speech recorders by *Information Storage Devices* and *Radio Shack*. Single chip solutions that eliminate any need for fancy A/D and D/A conversion. And that *Basic Stamp* microcontroller from *Parallax*.

Or that ultra low cost circuitry used in EKG pulse rate monitors. A complete micropower short-haul telemetry system in a cheap throwaway module.

Also by nearly any product that *Dallas Semiconductor* makes. Especially their "time in a can" dogtags.

What about the computer languages? Most fail elegant simplicity and do so abysmally. In fact, one good working definition of elegant simplicity is *What UNIX ain't*.

### ELEGANT SIMPLICITY RESOURCES

#### Adobe PostScript

1585 Charleston Road  
Mountain View, CA 94039  
(800) 833-6687

#### Dallas Semiconductor

4401 Beltwood Pkwy S  
Dallas, TX 75244  
(214) 450-0400

#### Exair

1250 Century Circle N  
Cincinnati, OH 45246  
(513) 671-3322

#### GEne PSRT

401 N. Washington St.  
Rockville, MD 20850  
(800) 638-9636

#### Information Storage Dev

2841 Junction, #204  
San Jose, CA 95134  
(408) 428-1400

#### Parallax

6359 Auburn Blvd, Ste C  
Citrus Heights, CA 95621  
(916) 721-8217

#### Vortec

10125 Carver Road  
Cincinnati, OH 45242  
(800) 441-7454

#### Whole Earth

27 Gate Five Road  
Sausalito, CA 94965  
(415) 332-1716

One superb example of elegant simplicity is WPL. An obscure scripting language for the Apple IIe *AppleWriter* word processor written by Paul Lutus. This real gem is a interpretable language that can automate word processing tasks. Elegantly and gracefully.

The WPL interpreter was written in a mere 1700 bytes of lovingly hand-crafted machine language code!

Portions of the general purpose PostScript computer language clearly offer elegant simplicity. Particularly its total device independence, its use of procedural character paths, graceful sparse curves, and powerful dictionary structures. Plus all the continuous on-the-fly high speed graphical transformations. Not to mention the power goodies in level II involving forms, FAX, open font paths, and outstanding color options.

My own personal favorite elegant simplicity ploy? Way back when I was in college, I used to consistently get the highest grades on my lab reports. Mostly because my lab reports were always thicker than the rest. The key secret to writing thick lab reports? *Thick paper!*

I have shown some follow-up names and numbers in the *elegant simplicity resources* sidebar. More on PostScript and such appears on [www.tinaja.com](http://www.tinaja.com).

But what did I miss? Surely you have several favorite examples of your own. Let's make a contest out of it. Just jot down your best shot at elegant simplicity and send it to me at *Synergetics*. There will be a dozen or so *Incredible Secret Money Machine II* books going to the winners, with an all all expense paid (FOB Thatcher, AZ) *tinaja quest* for two going to the very best of all. Let's hear from you. ♦

*Microcomputer pioneer and guru Don Lancaster is the author of 33 books and countless articles. Don maintains a US technical helpline you'll find at (520) 428-4073, besides offering all his own books, reprints and various services.*

*Don has a free new catalog crammed full of his latest insider secrets waiting for you. Your best calling times are 8-5 weekdays, Mountain Standard Time.*

*US callers only, please.*

*Don is also the webmaster of [www.tinaja.com](http://www.tinaja.com) where a special area has been set aside for Midnight Engineering readers. You can also reach Don at Synergetics, Box 809, Thatcher, AZ 85552. Or email [don@tinaja.com](mailto:don@tinaja.com)*



# Engineering Ratholes

**T**here sure seems to be an awful lot of really bad engineering coming down lately. Such as a short range missile that uses many *dozens* of slip rings. Or a zillion dollar remote infrared sensing system which replaces a penny's worth of temperature sensitive paint. A solar panel that generates electricity solely to *resistively* heat water! All to avoid a thirty cent drain valve.

A new "ultra efficient" engine. That seemingly avoids a minor motion conversion *non*-problem. While introducing insulated liquid sodium, magnetohydrodynamics, magnetic bearings, and incredibly complex electrics.

## Charging Madness

Or get this: An expensive and high profile ad campaign. Shows a ridiculously overdressed female. Standing beside a gas pump shaped power source. Holding a gas hose shaped cable. Plugging a gas nozzle shaped connector into an electric car. What is wrong with this picture?

Well, electric vehicles *will* autocharge. Unattended and contactless. From below. Not only is human intervention totally unneeded, it is quite costly, unsafe, inconvenient, and time wasting to do so.

Even the very concept of going someplace "special" to recharge your car does not make any sense at all. Card operated charging stations will end up *everywhere*. Every parking lot will have several. About the only place you'd be *unlikely* to find one is at a gas station.

## U-turn Insanity

It seems someone has patented a "U-turn" indicator for cars. Whenever you want to make a U-turn, you'll flip a special switch which progressively lights up a large rear pointing arrow.

Which gets me to thinking: How often does the average driver make a U-turn? How many people genuinely and truly care about telling the traffic behind them every time they make a U-turn? What percentage of the time will they do so? What is the amortized *per-turn* cost?

What is its investment payback period?

More importantly: When a random and unknown driver is presented with unexpected and confusing inputs during a high stress situation, will accidents *increase* or *decrease*?

What are the consequences of one litigious driver?

Now, I do not want to prejudge the answers to all these questions. U-turn indicators could see a groundswill of popular demand that rockets them into becoming the killer ap of the millenium. But your key point is that all these questions should have been asked – *and answered* – very

early in the product development cycle.

The patent, of course, is utterly worthless. It describes something completely obvious to any practitioner in the field. Worse, if such a device were really built, it would be as a *generic* icon display system, capable of *any* message or symbol. Rendering all patent claims moot.

## The Ratholes

One way to avoid bad engineering is to stay away from energy sinks into which bunches of time and money have previously been dumped with no visible effect. I like to call these *engineering ratholes*. Let's look at a few of the more popular examples coming over my voice helpline...

**Thermoelectric coolers** – The solid state *Peltier* coolers are certainly useful. When only *tiny* amounts of heat need be moved from point A to point B. But there is an absolute brick wall around eight watts or so. These devices are ludicrously inefficient. Often, five watts of heat have to be dumped to provide one watt or less of cooling. At high power, this causes your heatsink *rise* above ambient to *exceed* your net device cooling drop! (HACK68.PS)

**Stirling engines** – Every few years somebody rediscovers the Stirling engine. They build a few prototypes which just barely fail to work, and then just barely go bankrupt. The promise here sure is enticing. A low delta-T engine which accepts anything from oily rags to sunlight.

But there's two fundamental gotchas here. First, *any* engine designed for a low  $\Delta T$  temperature differential is *inherently* inefficient. Carnot and all. More crucially, there is a key component to a Stirling engine that nobody – but nobody – has figured out how to build yet. It is called a *regenerator*. A regenerator has to be long and thin and short and fat. Not to mention being an excellent insulator and a superb conductor. (HACK64.PS)

**Subsurface radar** – It is extremely difficult to couple any electromagnetic signal in to or out of the ground. Firstoff because of direct losses. Second because of severe coupling mismatch at the earth-air interface. And third because water has an enormously high dielectric constant. As a result, your effective ranges will *always* be ridiculously shorter than you'd first suspect.

Any "treasure finder" that claims a penetration greater than its length or whose resolution is less than one-tenth its sensor head size is highly suspect.

**Hall compasses** – Low cost sensors based upon the *Hall Effect* are really great for use as position pickoffs, current



monitors, or similar aps involving *strong* magnetic fields. But these are a *thousand times* too insensitive to be useful as a quality electronic compass.

Instead, *the* solution to low cost earth magnetometry is called the *fluxgate*. A saturated mag core with several windings. Been around for sixty years now, and still works like a champ. It ain't broke. (NUTS37.PDF)

**Anything automotive**– Sorry, kiddies, but this one is a closed club. Unless you are a SAE member, your father is a senior member, and your grandfather is a fellow emeritus, forget it. What's even worse is that all major players are dramatically *reducing* the number of their suppliers. And outsourcing engineering *only* to proven firms.

**High power piezo**– There are all sorts of wonderful new micropower aps for piezo stuff. Especially the great new materials from *Amp Kynar Piezo*. But except for a few resonant ultrasonic transducers, high power piezo seems doomed to failure. Indeed, every attempt at doing a motor or a stepper or a positioner beyond a one watt power level has been a commercial disaster.

The prospects for high level piezo power production are even more grim. Unlike a conventional "H-field" generator which produces a current through a conductor, piezo is an "E-field" machine which generates its voltage across an insulator. Guaranteeing an abysmal power density.

**Qwerty vs Dvorak**– The Qwerty keyboard was specifically designed to *slow typists down*. It has been one of the most ergonomically absurd designs of all time. But this one is so deeply culturally ingrained that *any* attempt to replace it is *guaranteed* to fail. You might bend it a little. Literally.

Or add a mouse substitute. Or argue over where to put the escape key. But *no way* are you going to replace it.

Proof of Qwerty's intractability? Most Apple computers let you instantly switch to a more ergonomic Dvorak key arrangement with a mouse click or two. Just try and find anybody anywhere who *ever* uses this feature.

**Cold fusion**– Died stillborn. Not only is their horse gone, but the barn door burned down and the entire farm is now a vacation condo. Pathological science at its bizarre worst.

**Tesla stuff**– Tesla was certainly one of the finest engineers of all time. Who developed both the induction motor and polyphase ac transmission. But he also was one of the greatest con artists this side of P.T. Barnum. And clearly was a few chips shy of a full board. There's a latter day cult built up around Tesla's "free energy" schemes.

Which flat out ain't gonna happen. (NUTS18.PS)

**Other pseudoscience** – If you've slept through Physics 101, the three laws of thermodynamics are: You can't win. You can't break even. And yeah, the dice are cooked, but it is the *only* game in town. Every attempt at perpetual motion to date has failed miserably. And virtually every other pseudoscience topic so far falls apart when given close enough scrutiny.

For a wondrously wacky tour of beyond the bizarre, check into the *KeelyNet BBS*. For a sanity check, go instead to the *Skeptical Inquirer*. (NUTS26.PS)

**Fuzzy logic and neural nets**– I sure enjoy watching Bob Pease slam these over in *Electronic Design*. Apparently,

## RATHOLE AVOIDANCE RESOURCES

### America On-Line

8619 Westwood Cntr Dr  
Vienna VA 22182  
(800) 827-6364

### GEnie

401 N Washington St  
Rockville MD 20850  
(800) 638-9636

### Amp Kynar Piezo

Box 799  
Valley Forge, PA 19482  
(610) 666-3500

### KeelyNet BBS

Box 1031  
Mesquite TX 75149  
(214) 324-3501 BBS

### CompuServe

5000 Arlington Center Blvd  
Columbus OH 43220  
(800) 848-8199

### Skeptical Inquirer

PO Box 703  
Buffalo NY 14226  
(716) 636-1425

### Dialog Information Svcs

3460 Hillview Ave  
Palo Alto CA 94304  
(415) 858-2700

### Synergetics

Box 809  
Thatcher AZ 85552  
(602) 636-1425

### Electronic Design

611 Rt #46 W  
Hasbrouck Heights NJ 07604  
(201) 393-6060

### Ulrichs Dictionary

121 Chanlon Rd  
New Providence NJ 07974  
(908) 771-7714

there *never* has been a real world Fuzzy Logic or Neural Net ap anytime ever that was even *remotely* as good as a well thought out traditional solution. To me, the whole field appears to be a huge smoke and mirrors scam.

Two key problems are that the math gets super ugly as the number of conditions go up. And that most proponents simply do not have the vaguest clue as to how a real world ap has to perform.

## Avoiding Bad Engineering

How can you personally avoid doing bad engineering? Here's some guidelines that may be of help...

**Get and stay informed**– Be sure you *thoroughly* understand the fundamental underpinnings of your target field. Don't write a forest fire simulation if you've never sharpened a *Pulaski*. The best and cheapest way to get informed is with all those zillions of free trade journals listed in *Ulrich's Periodicals Dictionary*.

**Get the necessary tools**– It never ceases to amaze me how many callers are trying to repair a tv or interface a monitor without using an oscilloscope. Or how many are still doing old line analog designs. When digital has done the task faster, cheaper, and more flexibly for well over a decade now. It is unthinkable to research astronomy without a telescope and a computer. The same fundamental tool need applies for *all* technical ventures.

**Ask who has gone before you**– Your concept is *not* new. Others are *certain* to have plowed this ground before. Who were they? What did they say where? What do you know that they don't? By far your most cost effective tool to find published info is the *Dialog Information Service*.

**Use online services aggressively**– Experts in *all* fields are a few modem bytes away. From the Internet, commercial BBS services, or local labor-of-love setups. It is *totally unthinkable* to attempt *any* technical venture today without tapping these incredible resources.

Your simplest Internet access is often by way of *GEnie*, *CompuServe* or *America Online*.

---

**Avoid the momentum trap**– Your initial designs *will* be wrong and *will* have to be modified. Every time. For the "real" problems do not appear until well into beta test. If you do all your work *knowing* that changes are *inevitable*, then you are less likely to lock in a lousy design.

**Beware the gotcha, my son**– There is not much point in working on a concept that goes head on against a Fortune 500 company. Or is in a field that abhors innovation. Or goes against the cultural grain. Or is legislated to death. Or has strong alternates. Or a narrow pre-obsolescence market window. Or invites costly litigation. Or has no buyers.

**Don't be overly enameled of your ideas**– If you are *very* lucky, one of your concepts in *five hundred* might end up a commercial success. Ideas are worth ten cents a bale in ten bale lots. Since most of your ideas are *guaranteed* to fail, it will pay to ruthlessly get rid of them just as *soon* as you possibly can. Stomp them out.

**No patents!**– Patents are a totally unneeded sideshow. One which is virtually *certain* to make your concept fail. Focus your time and energy on developing and improving your product instead. Rather than fruitlessly chasing mythical "protection". (WHEN2PAT.PS & PATNTHOR.PS)

**Shun paranoid secrecy**– Working by yourself in the dark is a sure fire formula for failure. The only reason to keep an idea or a concept a total secret is that it is so awful that you'd be embarrassed to tell anyone about it.

**Run a reality check**– Who cares about your product? What need does it fulfill? Who would buy it? One sure test is to locate *five* people who will agree *in writing* to buy your product. More importantly, who gets really upset over your design? Does it confront the big boys head on?

### For more help

Needless to say, any rathole can become an enormous opportunity. But only *after* you do thoroughly understand what went before. And only *when* you can bring something truly and genuinely new to the table.

Much more on all of these concepts shows up in my *Incredible Secret Money Machine II* and in my *Resource Bin* and *Blatant Opportunist* reprints. All of the mentioned filenames and continuing support on these topics appear on my *GENie PSRT RoundTable*.

I've managed to wrangle a ten free hour trial deal just for *Midnight Engineering* folks. Per details below. ♦

---

*Microcomputer pioneer and guru Don Lancaster is the author of 32 books and countless articles. Don maintains a no-charge technical helpline you'll find at (520) 428-4073, besides offering all his own books, reprints, and various services. Don has a free new catalog crammed full of his latest insider secrets waiting for you. The best calling times are 8-5 weekdays, Mountain Standard Time.*

*Don is also the sysop of GENie PSRT where a special area has been set aside for all you Midnight Engineering readers. For modem access, dial (800) 638-8369. When prompted, enter JOINGENIE. When asked for a keyword, enter DMD524. Or you can also reach Don at Synergetics, Box 809, Thatcher, AZ 85552.*

*Internet access: SYNERGETICS@GENIE.GEIS.COM*



Don Lancaster's

# Hardware Hacker

March, 1995

The DNA computer language  
Some wavelet book resources  
Magic digital sinewave codes  
Engineering economics review  
Hot new fringe FM RBDS tuner

As you might guess, I do get more than my share of high profile nastygrams. Lately, some of them seem to reveal a dismal ignorance of a fundamental engineering topic that nobody talks about too much. So, I guess it's way past time we took a look at...

## Efficiency and Engineering Economics

Otherwise known as the bang for the buck. *Efficiency* is simply how much of something you get back compared to what you put in. Physical systems *never* return more than you put in.

But an enterprise or a tech venture sometimes has an *apparent* efficiency well above 100%. This can happen if your rearrangements of the physical inputs and your personal value added causes the *perceived value* of your out-the-door products or services to exceed the cost of the parts, time, and effort that went into them.

*Engineering economics* is simply finding out exactly what the bang for the buck is. Get more than one buck back, and you'll have a "profit" or a "winner". Less than a buck back, and you probably should have been doing something else.

E&EE tells us why 6% efficient solar cells are useless electric power generators *at any price*. Even if free. Or why thermoelectric coolers simply *do not work* at power levels beyond eight watts or so.

Or why most solar space heating is impractical in much of Arizona. Or why it makes perfectly good sense to pour \$20,000 worth of electricity into the Gila River each year.

Or, for that matter, why it is totally insane to try and patent any million dollar idea. Or how I can easily win any one mile race. You in your BMW and me on my *Fuji* bicycle.

## Some Details

Say you want to start a technical venture. You first borrow a thousand dollars for your tools and materials. Today, the actual *time value of money* of those dollars will be somewhere

around ten percent. Thus, simply to break even, your venture has got to generate more than \$100 per year and do so forever.

But your tools and materials won't last forever. If they last for ten years, then your venture must generate more than \$270 per year to *amortize* your initial expense and the time value of money over the effective life. With a five year lifetime, your venture must generate more than \$329 per year.

Just to break even!

If your *total* cost is less than the returns, then you have an economic loss. The total costs must include all parts, labor, and your time value of money. Plus great heaping bunches of intangibles.

Not to mention taxes and inflation.

Paying cash does not make much difference. Since there's other things you might be doing with the money that gives better returns.

Sadly, any "hacker economy" that

substitutes time and energy for cash will only *shift* the viability breakeven points. Often by a lot less than you'd first guess. Even when you factor in entertainment, ego, and enjoyment.

A hacker economy does not in any way eliminate those fundamentals of engineering economics. And there's likely to be subsidies involved. Both subtle and obvious.

Another name for E&EE, of course, is a simple *reality check*.

Let's go back to our examples of really bad engineering economics:

The amount of electricity *per unit area* a six percent efficient solar cell produces cannot *ever* pay for all the installation, structure, interest, land, and operating expenses. The energy recovered is simply too diffuse. The longer you run it, the more it is going to cost you.

Besides their unreliability, this is what makes amorphous solar cells such dismally poor performers. Their

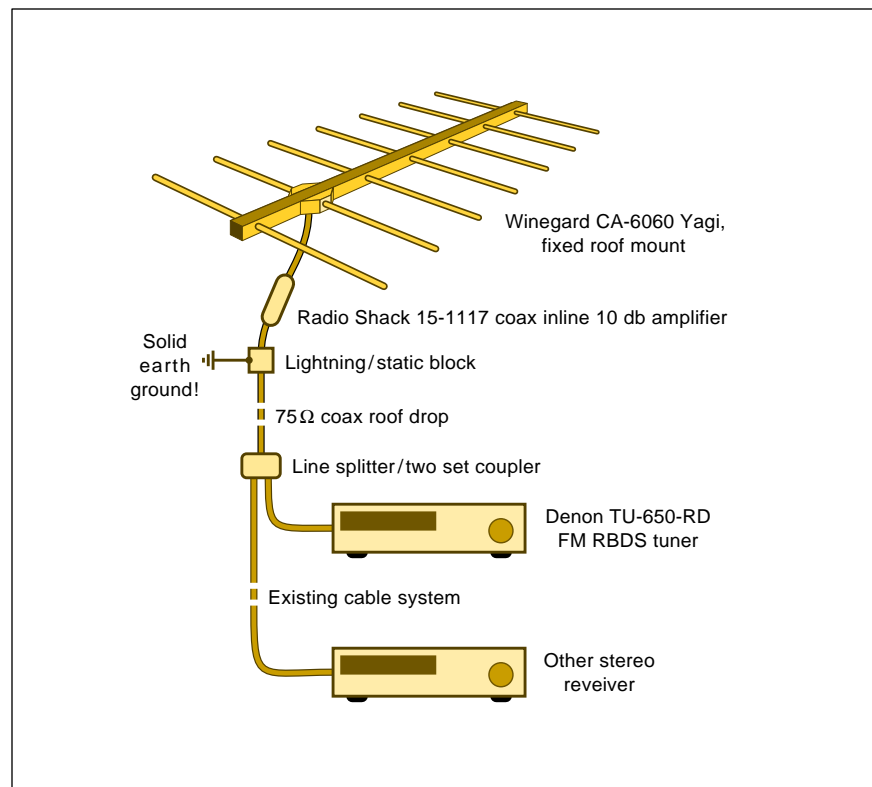

Fig. 1 – MY TEST SETUP for ultra-fringe FM and RBDS.

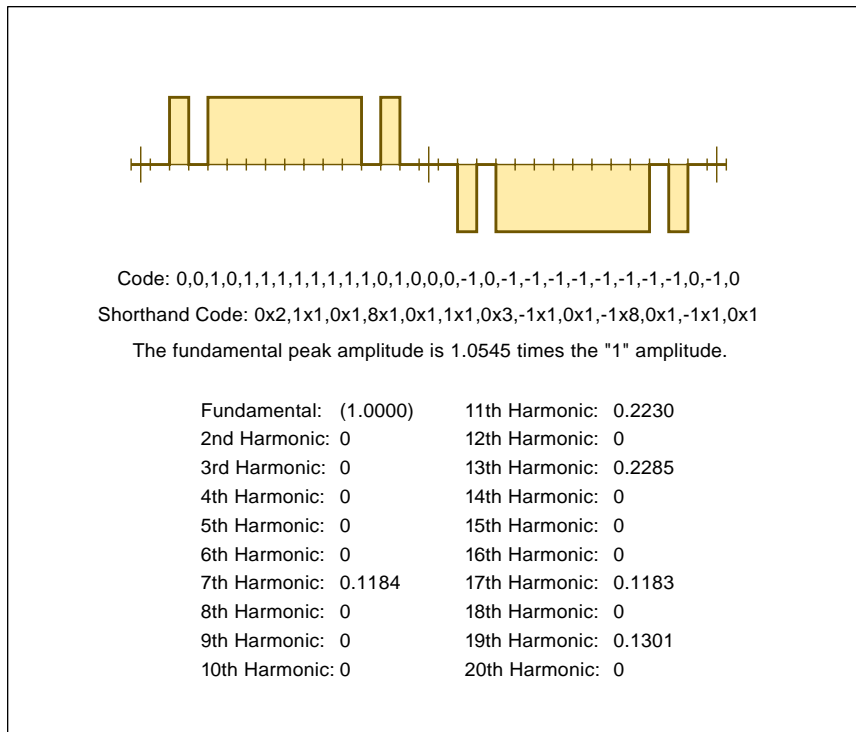

Fig. 2 – A "MAGIC" 30-BIT WAVEFORM for generating power sinewaves.

low efficiency is perilously close to economic breakeven. Which is also why commercial solar electric power plants are being chopped up and sold to hackers at yard sales. There is a lot more profit to be made in selling junk than there is in selling solar power from deteriorating cells.

In the Arizona desert, there are too few winter degree days to make solar space heating economical. It's hard to compete with \$10 worth of propane or a few sticks of wood.

Because of the gross inefficiency of thermoelectric coolers, your heat sink typically has to deal with six or more times your cooling power. At high power, the heat rise across your heatsink exceeds your cooling drop provided by the modules.

Making your "cooler" a heater!

Recovering that \$20,000 per year of Gila River electricity from a hot well down my street would demand a low delta-t plant. One whose design time, operating expenses, and time value of money would exceed income.

Especially in a flood plain.

Patenting your million dollar idea makes no sense at all. Why? Because there are not enough profits from a million dollar idea to begin to cover the costs of getting and successfully

defending a patent.

Your breakeven is roughly *twelve* million dollars in gross sales. At that 12 mil level, it is still a toss-up as to whether a patent is or is not worth all of the obscenely mind-rotting hassles involved. Much more on this in my WHEN2PAT.PS on [www.tinaja.com](http://www.tinaja.com).

Oh yeah. My bicycle race. You do, of course, have to include the time you spent working to pay for the part of the vehicle you used up during the race. Say you earn \$12 per hour after expenses. And it costs one dollar per mile to run your Beemer. Even if the BMW covers the mile at Mach 3, your minimum race time will end up five minutes or more.

Are there times when efficiency and engineering economics aren't of crucial importance? Only if nobody else can come up with a good answer to "Uh – Compared to What?"

Ferinstance, inefficient solar cells seem wonderful for calculators but useless for power generation. Peltier thermoelectrics are great for cooling a microscope slide, dewpoints, or an infrared detector. But worthless for making ice.

Solar hot water works really fine in the Arizona desert, but solar space heat does not.

## Wavelets Update

There's sure been a lot of interest in *wavelets* recently. These can be a super performing replacement for the older Fourier analysis techniques that relate time and frequency. Important usage areas include everything from video compression schemes to human vision to seismography.

Advanced math is required.

The field is maturing and there are now dozens of books available. I've listed several of the more popular of them in our resource sidebar.

The best tutorial paper is probably by Rioul and Vetterli in *IEEE Signal Processing Magazine*, vol 8, #4, Oct 1991 pp 14-38. Also check that Dec 1993 issue of their *IEEE Transactions on Signal Processing*. Note that these are two different pubs.

Yes, we have wavelet shareware up on [www.tinaja.com](http://www.tinaja.com)

## Hot New FM Tuner

In past issues and in the *Hardware Hacker* reprints, we've been looking at ultra-fringe FM reception as well as those new FM RBDS data services. The folks at *Denon* were kind enough to loan me one of their superb new TU-650-RD premium FM tuners. At \$375 list, \$299 or so street.

RBDS is a 1200 BPS data subcarrier service. An early intro shows up as HACK73.PS on my [www.tinaja.com](http://www.tinaja.com). Along with do-it-yourself circuits. The most common RBDS use is to show the call letters and station format. Other uses are for song, singer, traffic, weather, emergency alerts, GPS corrections, and coupon radio promotions.

Sadly, most FM stations have yet to pick up on this great new suite of services, all cheaply provided. The latest *Radio World* listing shows only 220 or so stations on line.

Besides showing the station call letters, this *Denon* receiver lets you search on format. Like asking it to scan only for classic rock.

There are now only a few Arizona stations offering RBDS. But several came in just fine. Even though most of them only provided the format and call letters so far. It seems the usual chicken-and-egg problem. Nobody wants RBDS if only a few stations have it; the stations do not want to

spend money on a service nobody is yet using very much.

But all the benefits are definitely there. Especially for car radios.

Scottsdale KSLX (100.7), Kingman KZZZ (94.7), and Cottonwood KZGL (95.9), broadcast the GPS corrections. Which upgrades position accuracy down to several feet.

The theory in *differential GPS* is that you have one known and *fixed* location at the radio station. Over several dozen miles, the errors at the radio station will be pretty much the same as the error in your instrument. You just subtract the two to pick up a lot more accuracy.

More on these techniques in *GPS World*. Two major RBDS resources include *Differential Corrections* and *Coupon Radio*.

The Denon receiver would have to be slightly modified to receive GPS. This is a custom and encrypted fee based commercial service.

There are several unique features that make their TU-650-RD a good ultra-fringe receiver. A fully shielded super hot front end design. And an optional narrow band if filter that blocks most co-channel interference. Yes, you can still receive stereo and RBDS in the narrow mode.

Figure one shows my current test setup. A high fixed mount *Winegard* CA-6060 ten element Yagi on the roof pointed due west. A lightning block and ten decibel *Radio Shack* 15-1117 amplifier on the antenna. A two-set coupler in the living room driving the TU-650-RD. And on back through the previous cable system going to the second and lower quality receiver in the computer room.

Performance? First and foremost, KDKB comes in like a champ. You can arc weld with their signal. Which is all that really matters to me. There are some 40 FM stations of listenable quality. At an *average* distance of over 105 miles!

Their if filter is incredible. Weak Tucson alternate radio KXCI at 91.3 gets easily separated from the much stronger Phoenix KJZZ at 91.5.

The rule on a bandpass filter is to try it and see. If the station *changes*, or the noise goes *up*, you have got co-channel problems. But any weak signal by itself might come in better with or without the filter. In general,

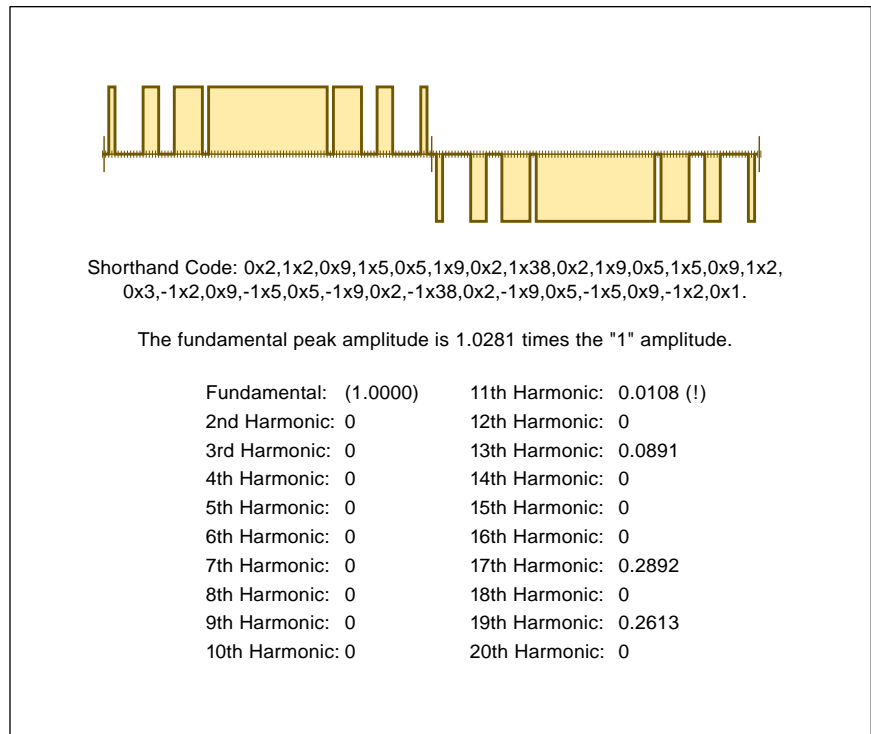

Fig. 3 – AN "EVEN MORE MAGIC" power sinewave waveform of 210 bits.

the filter only makes a difference on a few stations.

But what a difference.

Does it make sense to add a lower quality booster at the antenna ahead of an ultra hot receiver? A modest 10 db boost at your antenna gives your antenna a fixed impedance to work into and makes up for both line and distribution losses.

The slightly higher signal level is enough to override the "no stereo on weak signal" feature. Which lets you switch by yourself rather than using the factory preset. Naturally, mono is cleaner for marginal signals.

But any preamp also adds to your cross mod and can cause overloading. Which was only observable at half a

channel away from a nearby station. If you use a preamp, be sure to use an inline coax version which is totally shielded. Providing you with only the bare minimum gain needed.

Does a fixed antenna make sense? Fixed is cheaper and more rugged. And there's not too much east of me because of this slight rise that some folks call the Continental Divide.

But Bee does not get her classic Tucson KUAT very well. Despite its strong reception on the car radio in the driveway. Some sniffing around with an unboosted cheap fringe-but-not-ultra *Radio Shack* 15-1636 FM antenna led to a big surprise.

A large number of FM stations appear to now use *vertical* or *circular* polarizations. Their apparent aim is to improve nearby auto reception at the cost of distant coverage.

For KUAT, flipping the antenna to the vertical dramatically improved the reception in Thatcher.

The ultimate solution is antenna height. Which conquers all. At the top of the two mile high mountain in my front yard, I can take a \$4 pocket FM receiver and tune it to 93.3. By pointing the whip antenna in one of three directions, I can get KDKB in Phoenix, KKOB in Albuquerque or a

**NEED HELP?**

Phone or write all your US Tech Musings questions to:

Don Lancaster  
Synergetics  
Box 809-EN  
Thatcher, AZ, 85552  
(520) 428-4073

US email: [don@tinaja.com](mailto:don@tinaja.com)  
Web page: [www.tinaja.com](http://www.tinaja.com)



## WAVELET BOOK RESOURCES

- C.K. Chui, *An Introduction to Wavelets*, Academic Press, 1992.
- C.K. Chui, *Wavelets*, World Scientific Pub, 1992.
- C.K. Chui, *Wavelets: A Tutorial in Theory & Applications*, Academic Press, 1992.
- C.K. Chui, L. Montefusco & L. Puccio, *Wavelets, Theory, Algorithms, & Applications*, Academic Press, 1994.
- J.M. Combes, *Wavelets*, Spr-Verlag, 1989.
- I. Daubechies, *Ten Lectures on Wavelets*, Soc Indus-Appl Math, 1992.
- G. David, *Wavelets & Singular Integrals on Curves & Surfaces*, Spr-Verlag, 1992.
- M. Farge, *Wavelets, Fractals & Fourier Transforms*, 1993.
- E. Foufoula-Georgiou, P. Kumar, *Wavelets in Geophysics*, Academic Press, 1994.
- Frazier, *Wavelets, Mathematics & Applications*, CRC Press, 1993.
- Jawerth, *Practical Guide to Wavelets*, CRC Press, 1994.
- G. Kaiser, *A Friendly Guide to Wavelets*, Birkhauser, 1993.
- T.H. Koornwinder, *Wavelets: An Elementary Treatment of Theory & Application*, World Scientific Pub, 1993.
- W. Light, *Advances in Numerical Analysis*, V2, OUP, 1992.
- Y. Meyer, *Wavelets: Algorithms & Applications*, Soc Indus-Appl Math, 1993.
- Y. Meyer, *Wavelets*, Cambridge University Press, 1993.
- Y. Meyer, *Wavelets & Applications*, Spr-Verlag, 1992.
- R.L. Motard & B Joseph, *Wavelet Applications in Chemical Engineering*, Kluwer Ac, 94.
- D.E. Newland, *An Introduction to Random Vibrations, Spectral & Wavelet Analysis*, Halsted Press, 1993.
- Ruskai, *Wavelets & Their Applications*, Jones & Bartlett, 1992.
- L.L. Schumaker & G. Webb, *Recent Advances in Wavelet Analysis*, Acad. Pr., 1993.
- G.G. Walter, *Wavelets & Other Orthogonal Systems with Applications*, CRC Press, 94.
- G. Wornell, *Wavelet-Based Signal Processing with Fractals*, P-H, 1994.
- R.K. Young, *Wavelet Theory & Its Applications*, Kluwer Ac, 1992.

Mexican station from the south.

Tuning on the TU650RD is every 100 kiloHertz, giving you one stop *between* channels. This could reduce co-channel interference or might be useful for some homebrew wireless broadcaster that is off frequency. It also helps the channel six tv sound near 87.8 MegaHertz.

One strange restriction: This tuner is so hot you'll have to activate the internal rf attenuator to prevent any overload on cable systems. For some reason, you can only do this from the remote. I suspect this may have been an afterthought when the design was nearly completed.

Because there is a microcontroller inside, you'll find all sorts of unusual features. You can manually teach any *non*-RBDS stations their call letters and formats. Or store other messages

of 13 or fewer characters.

You can scan for all of the classic rock stations, all the news stations, or any of 20 other formats. Since there is no keyboard as such, you use the *up/down* button to select any of the 66 characters. Which is not quite as bad as it sounds.

There are 30 station presets. These are bright enough to remember the RBDS or manually entered data, AM versus FM, the rf attenuator setting, and the filter bandwidth.

There is a panel light dimmer. All presets get saved during power down.

The power consumption is only 12 watts. Being a component tuner, an external stereo amplifier is needed.

I'd sure like to see a "raw" RBDS output jack on this product.

The next step here is obvious. A monthly updated plug in card, chip,

or modem line that stores *all* of the stations in North America with all of their formats and the operating hours. Which would be most useful for long auto trips.

## More "magic" Waveforms

High power sinewaves are quickly becoming one hot hardware hacker topic. For such uses as car battery power inverters, UPS computer power supplies, telephone ringers, electric autos, line conditioning, and variable speed induction motor drives.

Most of these apps *demand* fairly decent sinewave outputs. Square or other sloppy waveforms could cause inefficiencies, heating, resonances, cogging, or severe audio whine.

Analog solutions which use power amplifiers will not hack it because of their lousy efficiency.

A microcontroller oriented digital solution is the *only* route to use these days. Especially when stability, wide range, easily adjusted voltage, or a constant speed is involved.

You'll also want to minimize how many power switches you use. And you'll want your switch currents to be reasonably efficient.

So, the trick is to find a "magic" single train of fixed amplitude ones and zeros that could fake a decent variable voltage sinewave. Often, you will pick a RZ or *ternary*, or PWM pulse width modulation scheme that has states of +1, 0 and -1.

Figure two shows a wonderfully "magic" 30 bit waveform for power sinewaves. When you go through *all* possible binary sequences for 36 or less bits per word, there is *no* other code that even comes close.

The "top" half of your waveform is 00101111111010. The "bottom" half gets repeated with -1 values. Note that you mirror top-to-bottom but *not* right-to-left! Giving you the 30 bit word. Or a 1800 Hertz clock for 60 Hertz line power. The 30 bit length nicely taps out by tens if you need three phase power.

Believe it or not, this elegantly simple "magic" word has a *zero* dc term. It has *zero* second, third, fourth, fifth, sixth, eighth, ninth, and tenth harmonics! The peak fundamental is around five percent *above* the "1" value, for nicely behaved switching currents. The seventh harmonic ends



**NAMES AND NUMBERS**

**Coupon Radio**  
10 Rockefeller Plaza  
New York NY 10020  
(212) 595-1313

**Crystal Semiconductor**  
PO Box 17847  
Austin TX 78744  
(800) 888-5016

**Dallas Semiconductor**  
4401 South Beltwood Pkwy  
Dallas TX 75244  
(214) 450-0400

**Denon**  
222 New Road  
Parsippany NJ 07054  
(201) 575-7810

**Differential Corrections**  
10121 Miller Avenue #201  
Cupertino CA 95014  
(800) 446-0015

**GEne**  
401 North Washington Street  
Rockville MD 20850  
(800) 638-9636

**GPS World**  
859 Willamette Street  
Eugene OR 97440  
(503) 343-1200

**IEEE/Signal Processing**  
445 Hoes Lane  
Piscataway NJ 08855  
(908) 981-0060

**National Semiconductor**  
2900 Semiconductor Drive  
Santa Clara CA 95052  
(800) 272-9959

**Radio World**  
5827 Columbia Pk #310  
Falls Church VA 22041  
(703) 998-7600

**Science/AAAS**  
1333 H Street NW  
Washington DC 20005  
(202) 326-6400

**Synergetics**  
Box 809  
Thatcher AZ 85552  
(520) 428-4073

**Whole Earth Catalog**  
27 Gate Five Road  
Sausalito CA 94965  
(415) 332-1716

**Winegard**  
3000 Kirkwood Street  
Burlington IA 52601  
(319) 754-0600

up around 11.8% amplitude, which will translate to 1.39% power.

Uh, there are a few minor points over this one, though. There's flat out no way you are going to get all those fancy square corners with nothing but a fundamental sinewave and a weak seventh harmonic.

So, all the 11, 13, 17, and 19 teen harmonics are sorta gruesome. But no worse than the third in any plain old square wave. They end up mid-audio with 60 Hertz power. But these are usually easy to filter out. Even the winding inductance of a motor acts as a low pass filter.

Still, you will definitely need some low pass filtering and you will have to watch for system resonances.

Note that the "-1" state can simply be a reversed current. With a bridge driver, only a single supply is needed for both current directions. Another option is to use a *pair* of oppositely phased windings.

Details vary with the use and your intended application..

Naturally, the fine general purpose PostScript computer language is *the* quick and fun way to interactively analyze waveforms. I've written a new [FOURIER.PS](#) tutorial exploration utility and my [ZEROHARM.PS](#) code finder to [www.tinaja.com](http://www.tinaja.com)

I'm currently checking out 210 bit words using PostScript. One highly interesting 210 bitter is shown in figure three. Whose very first nasty harmonic is the *seventeenth*.

A library of low harmonic codes with listings of different fundamental amplitudes can be used to provide variable output voltage from a fixed supply. Call me for details.

At longer bit lengths, you do have to think smarter rather than harder to quickly get any useful answers. But PostScript does explore any high bit count words with aplomb. The key secret is to represent your words by ones and zeros *in a string*. And then manipulate the strings.

Many thanks to mathematician Jim Fitzsimons for his help on this.

**new from DON LANCASTER**

**ACTIVE FILTER COOKBOOK**

The sixteenth (!) printing of Don's bible on analog op-amp lowpass, bandpass, and highpass active filters. De-mystified instant designs. **\$28.50**

**CMOS AND TTL COOKBOOKS**

Millions of copies in print worldwide. THE two books for digital integrated circuit fundamentals. About as hands-on as you can get. **\$28.50** each.

**INCREDIBLE SECRET MONEY MACHINE II**

Updated 2nd edition of Don's classic on setting up your own technical or craft venture. **\$18.50**

**LANCASTER CLASSICS LIBRARY**

Don's best early stuff at a bargain price. Includes the CMOS Cookbook, The TTL Cookbook, Active Filter Cookbook, PostScript video, Case Against Patents, Incredible Secret Money Machine II, and Hardware Hacker II reprints. **\$119.50**

**LOTS OF OTHER GOODIES**

- Ask the Guru I or II or III . . . . . \$24.50
- Hardware Hacker II, III or IV . . . . . \$24.50
- Micro Cookbook I . . . . . \$19.50
- PostScript Beginner Stuff . . . . . \$29.50
- PostScript Show and Tell . . . . . \$29.50
- Intro to PostScript Video . . . . . \$29.50
- PostScript Reference II . . . . . \$34.50
- PostScript Tutorial/Cookbook . . . . . \$22.50
- PostScript by Example . . . . . \$32.50
- Understanding PS Programming . . . . . \$29.50
- PostScript: A Visual Approach . . . . . \$22.50
- PostScript Program Design . . . . . \$24.50
- Thinking in PostScript . . . . . \$22.50
- LaserWriter Reference . . . . . \$19.50
- Type 1 Font Format . . . . . \$16.50
- Acrobat Reference . . . . . \$24.50
- Whole works (all PostScript) . . . . . \$380.00
- Synergetics Surplus Catalog . . . . . **FREE**
- Technical Insider Secrets . . . . . **FREE**

**POSTSCRIPT SECRETS**

A Book/Disk combination crammed full of free fonts, insider resources, utilities, publications, workarounds, fontgrabbing, more. For most any PostScript printer. Mac or PC format. **\$29.50**

**BOOK-ON-DEMAND PUB KIT**

Ongoing details on Book-on-demand publishing, a new method of producing books only when and as ordered. Reprints, sources, samples. **\$39.50**

**THE CASE AGAINST PATENTS**

For most individuals, patents are virtually certain to result in a net loss of sanity, energy, time, and money. This reprint set shows you Don's tested and proven real-world alternatives. **28.50**

**BLATANT OPPORTUNIST I**

The reprints from all Don's Midnight Engineering columns. Includes a broad range of real world, proven coverage on small scale technical startup ventures. Stuff you can use right now. **\$24.50**

**RESOURCE BIN I**

A complete collection of all Don's Nuts & Volts columns to date, including a new index and his master names and numbers list. **\$24.50**

**FREE SAMPLES**

Check Don's Guru's Lair at <http://www.tinaja.com> for interactive catalogs and online samples of Don's unique products. Searchable reprints and reference resources, too. Tech help, hot links to cool sites, consultants. email: [don@tinaja.com](mailto:don@tinaja.com)

FREE US VOICE HELPLINE VISA/MC

**SYNERGETICS**  
Box 809-NV  
Thatcher, AZ 85552  
(520) 428-4073

### New Tech Lit

From *Crystal Semiconductor* a new *Audio Databook*. On digital audio products, particularly low distortion delta-sigma A/D converters.

From *Dallas Semiconductor*, a *System Extension Data Book*. This book includes digital potentiometers and electronic thermostats.

From *National Semiconductor*, a *Power IC's Databook*. Full of linear and switching regulators, motion controls, and power drivers.

That November 24, 1994 issue of *Science* proves something that has been completely obvious to me for some time. That 97% of so-called "junk" DNA is really a sophisticated

computer language! Or, at the very least, passes all the exact tests in the same ways that *all* current human and computer languages do.

Details on page 1320.

If you want to make a real quick buck on this, just publish the pocket reference card for the DNA language. And maybe show us how to access a utility subroutine or two.

At long last, the *Millenium Whole Earth Catalog* is shipping. A "must have" essential resource on access to tools. Don't miss this one.

I've just newly reissued my classic *Active Filter Cookbook* and do have bunches of autographed copies on hand. And I do still have scads of classic Apple computers, monitors,

cards, and drives on hand. Cheap enough for use as a programmable controller. Even rare and collectible Apple III's. Write, call, or email me for more details.

A reminder that unique downloads, freebie insider secrets, catalogs, and technical help are available on my [www.tinaja.com](http://www.tinaja.com). More info per the *Need Help?* box.

Please note that my area code has just changed to 520. Be sure to update any earlier catalogs or whatever I may have sent you.

As usual, most of these resources I've mentioned appear in the *Names & Numbers* or *Wavelets* sidebars. Be sure to check here first before you call our no-charge tech helpline. ♦

## **NEED HELP?**

Phone or write **Case Against Patents** questions to:

Don Lancaster  
**SYNERGETICS**  
Box 809  
Thatcher, AZ 85552

VOICE: (520) 428-4073  
Internet: [www.tinaja.com](http://www.tinaja.com)  
[don@tinaja.com](mailto:don@tinaja.com)

