

| REV | ZONE | REVISION | DESCRIPTION | BY | DATE | CHK |
|-----|------|--|--|-------|----------|-----|
| A | D-1 | CHANGED '03' TO '03', '04' TO '04', '01' TO '01', '02' TO '02', '05' TO '05', '06' TO '06', '07' TO '07', '08' TO '08', '09' TO '09', '10' TO '10', '11' TO '11', '12' TO '12', '13' TO '13', '14' TO '14', '15' TO '15', '16' TO '16', '17' TO '17', '18' TO '18', '19' TO '19', '20' TO '20', '21' TO '21', '22' TO '22', '23' TO '23', '24' TO '24', '25' TO '25', '26' TO '26', '27' TO '27', '28' TO '28', '29' TO '29', '30' TO '30', '31' TO '31', '32' TO '32', '33' TO '33', '34' TO '34', '35' TO '35', '36' TO '36', '37' TO '37', '38' TO '38', '39' TO '39', '40' TO '40', '41' TO '41', '42' TO '42', '43' TO '43', '44' TO '44', '45' TO '45', '46' TO '46', '47' TO '47', '48' TO '48', '49' TO '49', '50' TO '50' | CHANGED '03' TO '03', '04' TO '04', '01' TO '01', '02' TO '02', '05' TO '05', '06' TO '06', '07' TO '07', '08' TO '08', '09' TO '09', '10' TO '10', '11' TO '11', '12' TO '12', '13' TO '13', '14' TO '14', '15' TO '15', '16' TO '16', '17' TO '17', '18' TO '18', '19' TO '19', '20' TO '20', '21' TO '21', '22' TO '22', '23' TO '23', '24' TO '24', '25' TO '25', '26' TO '26', '27' TO '27', '28' TO '28', '29' TO '29', '30' TO '30', '31' TO '31', '32' TO '32', '33' TO '33', '34' TO '34', '35' TO '35', '36' TO '36', '37' TO '37', '38' TO '38', '39' TO '39', '40' TO '40', '41' TO '41', '42' TO '42', '43' TO '43', '44' TO '44', '45' TO '45', '46' TO '46', '47' TO '47', '48' TO '48', '49' TO '49', '50' TO '50' | JIM F | 11/30/92 | |
| B | B-1 | ADDED K, Z3, AND J | ADDED K, Z3, AND J | JIM F | 10/6/93 | |
| C | C-1 | ADDED FLAGS | ADDED FLAGS | JIM F | 11/6/96 | |
| D | A-1 | 205211-1 WAS 205212-1 FOR FLAG 2, 205212-1 WAS 205211-1 FOR FLAG 3 | 205211-1 WAS 205212-1 FOR FLAG 2, 205212-1 WAS 205211-1 FOR FLAG 3 | | 7/13/00 | |

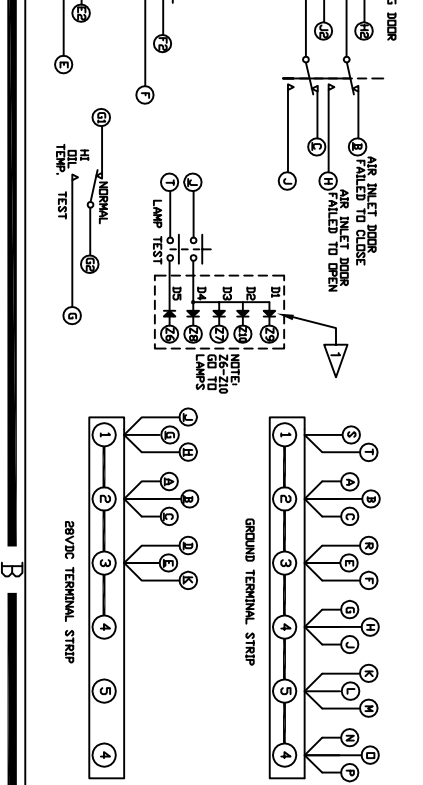
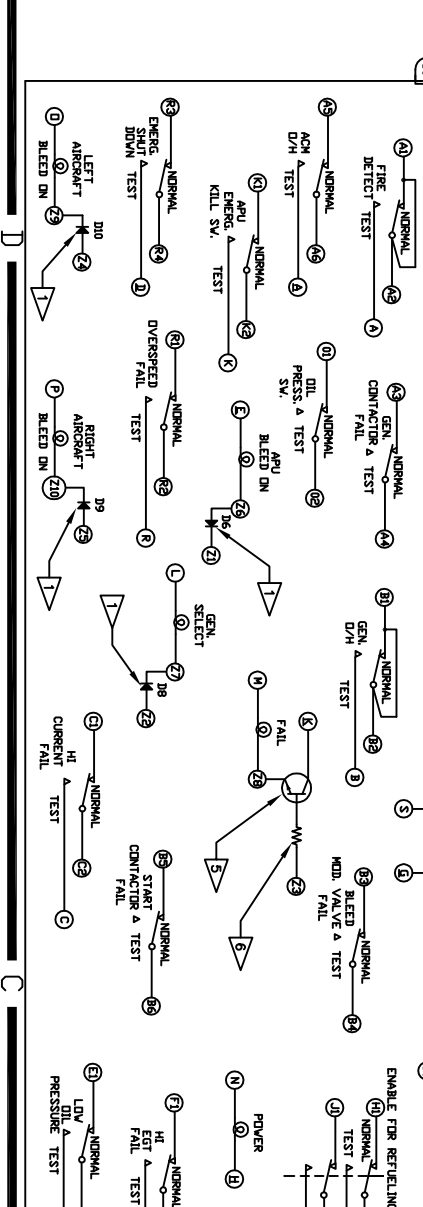
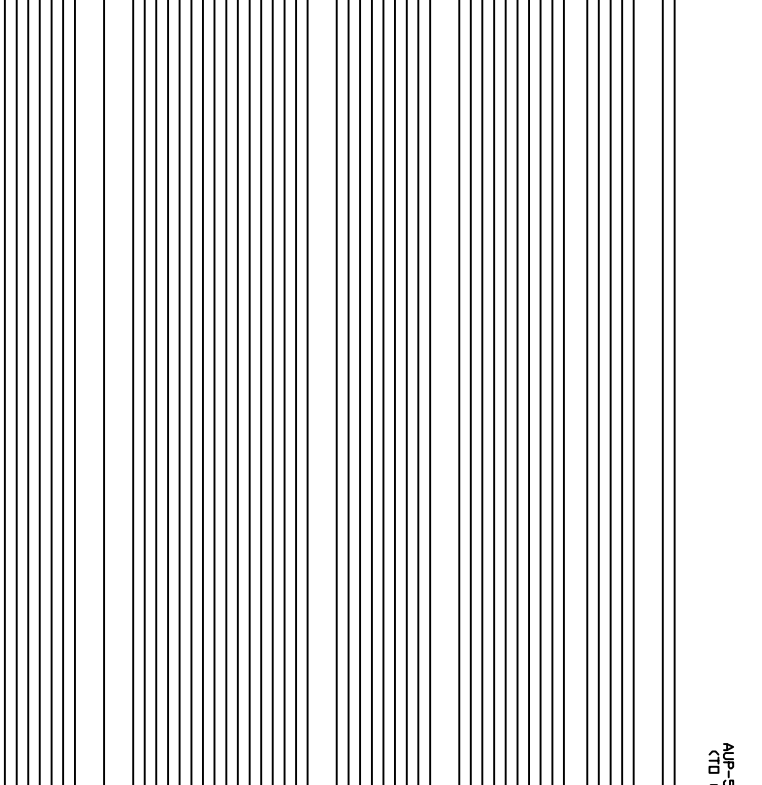
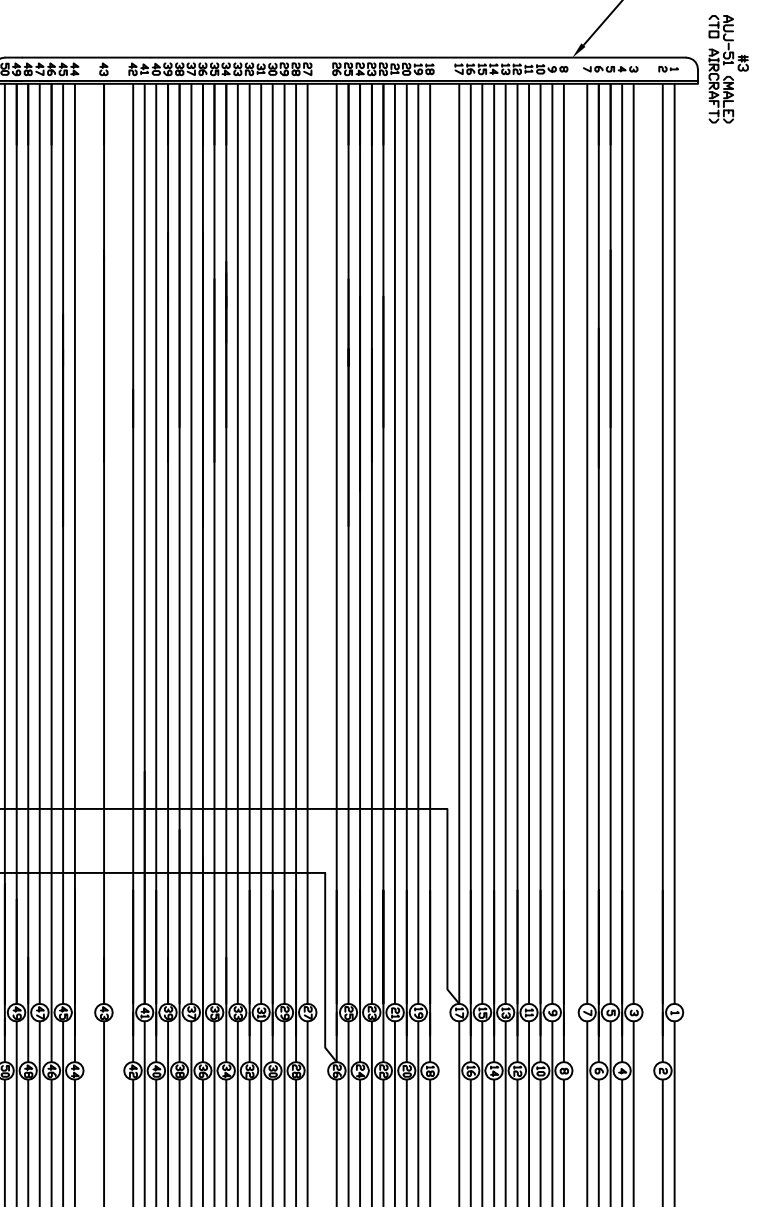
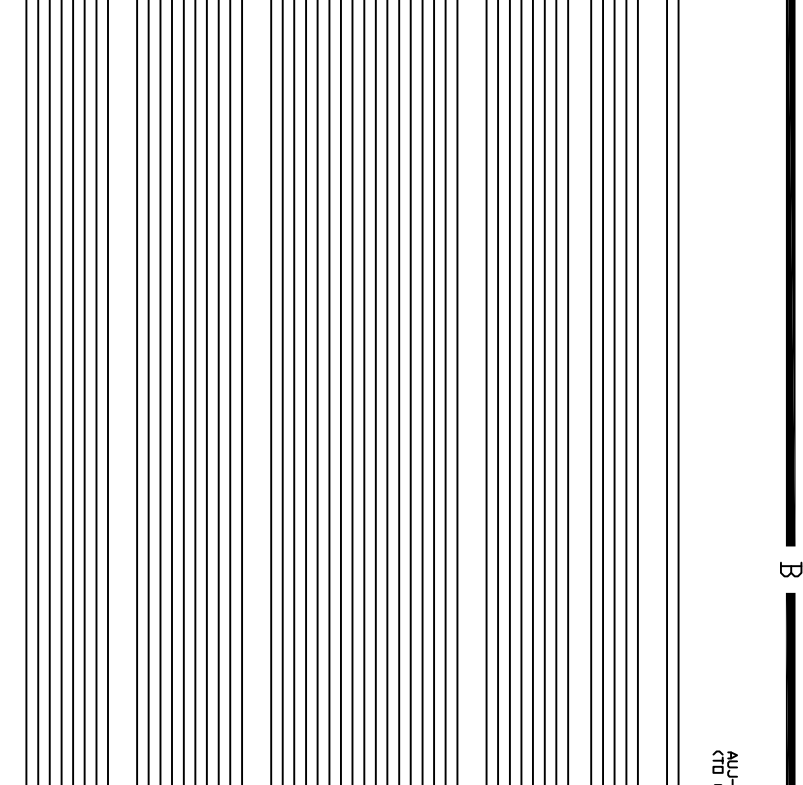
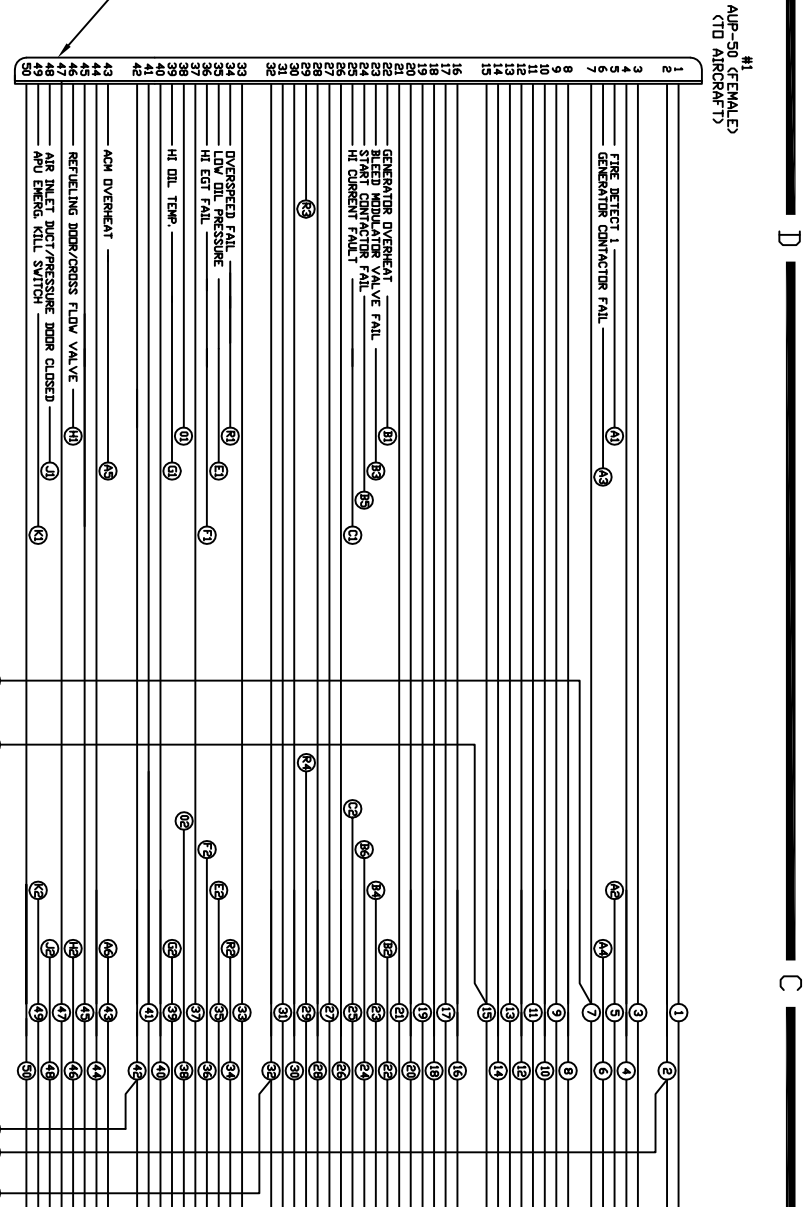

| QTY | PART NUMBER OR REG'D IDENTIFYING NUMBER | DESCRIPTION | MATERIAL OR NOTE |
|-----|---|---------------------------|--------------------------------|
| 1 | DA150-1 | BOX ASSEMBLY | ▷ |
| 1 | 1/4 WATT 10K OHM | RESISTOR | ▷ |
| 1 | 2W2222 | TRANSISTOR | ▷ |
| 30 | 31885 | #6 (RED) RING TERMINAL | ▷ |
| 100 | 205090-1 | FEMALE D SERIES PINS | ALTERNATE P/N 36150 |
| 100 | 205089-1 | MALE D SERIES PINS | |
| 4 | 20572-1 | 50 PIN AMP. HEADS | ▷ |
| 2 | 205212-1 | 50 PIN D SERIES CONNECTOR | ▷ (MALE PLUG - FEMALE SOCKETS) |
| 2 | 205211-1 | 50 PIN D SERIES CONNECTOR | ▷ (FEMALE PLUG - MALE PINS) |
| 10 | 1N2069 | DIODE | ▷ |

INFORMATION CONTAINED HEREIN IS UNCLASSIFIED AND HAS NOT BEEN REPRODUCED WITHOUT WRITTEN CONSENT DRI

DUNGAN AVIATION, INC.
1101 RIVINGTON RD.
LINCOLN, NE 68501

TITLE: APU SAFETY TEST BOX

DRAWING NO: DA250

DATE: 8-9-89

DESIGNER: J.H.

CHECKER: JIM F.

APPROVER: JIM F.

SCALE: N/A.

REG. NO: DA250-D1

MODEL: 1

BY: JIM F

DATE: 11/30/92

CHK: JIM F

DATE: 10/6/93

CHK: JIM F

DATE: 11/6/96

CHK: JIM F

DATE: 7/13/00

CHK: JIM F

| REV | ZONE | REVISION | DESCRIPTION | BY | DATE | CHK |
|-----|------|--|--|-------|----------|-----|
| A | D-1 | CHANGED '03' TO '03', '04' TO '04', '01' TO '01', '02' TO '02', '05' TO '05', '06' TO '06', '07' TO '07', '08' TO '08', '09' TO '09', '10' TO '10', '11' TO '11', '12' TO '12', '13' TO '13', '14' TO '14', '15' TO '15', '16' TO '16', '17' TO '17', '18' TO '18', '19' TO '19', '20' TO '20', '21' TO '21', '22' TO '22', '23' TO '23', '24' TO '24', '25' TO '25', '26' TO '26', '27' TO '27', '28' TO '28', '29' TO '29', '30' TO '30', '31' TO '31', '32' TO '32', '33' TO '33', '34' TO '34', '35' TO '35', '36' TO '36', '37' TO '37', '38' TO '38', '39' TO '39', '40' TO '40', '41' TO '41', '42' TO '42', '43' TO '43', '44' TO '44', '45' TO '45', '46' TO '46', '47' TO '47', '48' TO '48', '49' TO '49', '50' TO '50' | CHANGED '03' TO '03', '04' TO '04', '01' TO '01', '02' TO '02', '05' TO '05', '06' TO '06', '07' TO '07', '08' TO '08', '09' TO '09', '10' TO '10', '11' TO '11', '12' TO '12', '13' TO '13', '14' TO '14', '15' TO '15', '16' TO '16', '17' TO '17', '18' TO '18', '19' TO '19', '20' TO '20', '21' TO '21', '22' TO '22', '23' TO '23', '24' TO '24', '25' TO '25', '26' TO '26', '27' TO '27', '28' TO '28', '29' TO '29', '30' TO '30', '31' TO '31', '32' TO '32', '33' TO '33', '34' TO '34', '35' TO '35', '36' TO '36', '37' TO '37', '38' TO '38', '39' TO '39', '40' TO '40', '41' TO '41', '42' TO '42', '43' TO '43', '44' TO '44', '45' TO '45', '46' TO '46', '47' TO '47', '48' TO '48', '49' TO '49', '50' TO '50' | JIM F | 11/30/92 | |
| B | B-1 | ADDED K, Z3, AND J | ADDED K, Z3, AND J | JIM F | 10/6/93 | |
| C | C-1 | ADDED FLAGS | ADDED FLAGS | JIM F | 11/6/96 | |
| D | A-1 | 205211-1 WAS 205212-1 FOR FLAG 2, 205212-1 WAS 205211-1 FOR FLAG 3 | 205211-1 WAS 205212-1 FOR FLAG 2, 205212-1 WAS 205211-1 FOR FLAG 3 | | 7/13/00 | |

UNLESS OTHERWISE SPECIFIED:
DIMENSIONS ARE IN INCHES
TOLERANCES: X ± .10, XX ± .05, XXX ± .010
ANGLES ± .5°, BREAK ALL SHARP EDGES
DID NOT SCALE PRINT
A/R = AS REQUIRED

DATE: 8-9-89
DESIGNER: J.H.
CHECKER: JIM F.
APPROVER: JIM F.
SCALE: N/A.
REG. NO: DA250-D1
MODEL: 1
BY: JIM F
DATE: 11/30/92
CHK: JIM F
DATE: 10/6/93
CHK: JIM F
DATE: 11/6/96
CHK: JIM F
DATE: 7/13/00
CHK: JIM F